

Quad high-side smart power solid-state relay

Datasheet - production data



- Open drain diagnostic outputs
- 3.3 V CMOS/TTL compatible inputs
- Fast demagnetization of inductive loads
- Conforms to IEC 61131-2
- ESD according to IEC 61000-4-2 up to +/- 25 kV

Features

Type	$V_{\text{demag}}^{(1)}$	$R_{\text{DS(on)}}^{(1)}$	$I_{\text{out}}^{(1)}$	V_{CC}
VNI4140K	$V_{\text{CC}}-41 \text{ V}$	0.08Ω	0.7 A	41 V

1. Per channel.

- Output current: 0.7 A per channel
- Shorted load protections
- Junction overtemperature protection
- Case overtemperature protection for thermal independence of the channels
- Thermal case shutdown restart not simultaneous for the various channels
- Protection against loss of ground
- Current limitation
- Undervoltage shutdown

Description

The VNI4140K is a monolithic device made using STMicroelectronics VIPower technology, intended to drive four independent resistive or inductive loads with one side connected to ground. Active current limitation avoids dropping the system power supply in case of shorted load. Built-in thermal shutdown protects the chip from overtemperature and short-circuit. In overload conditions, channel turns OFF and back ON automatically so to maintain junction temperature between T_{TSD} and T_{R} . If this condition makes case temperature reach T_{CSD} , overloaded channel is turned OFF and restart only when case temperature has decreased down to T_{CR} . In case of more than one channel in overload, restart of the overloaded channels is not simultaneous, in order to avoid high peak current from the supply. Non-overloaded channels continue operating normally. The open drain diagnostics outputs indicate overtemperature conditions.

Figure 1. Block diagram

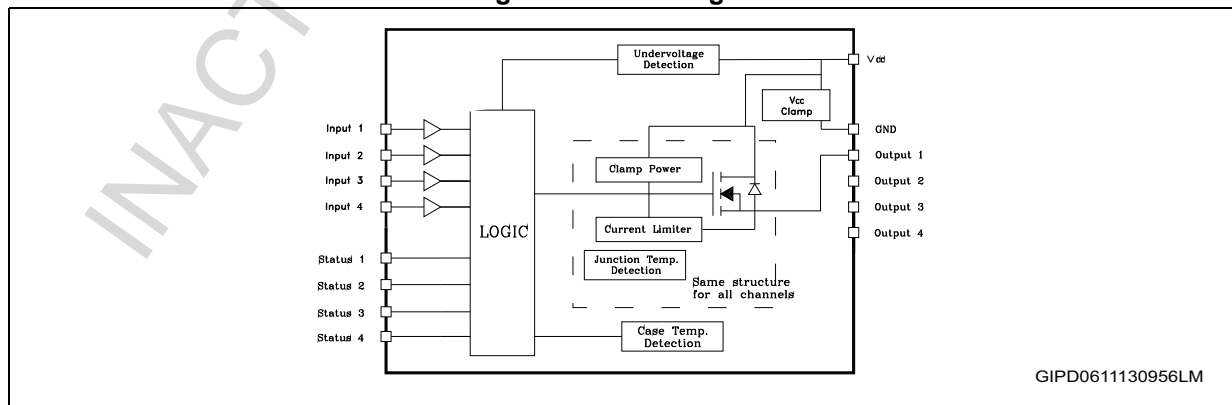

Contents

1	Pin connection	3
2	Maximum ratings	5
	2.1 Thermal data	5
3	Electrical characteristics	6
4	Truth table	9
5	Typical application circuit	9
6	Switching waveforms	11
7	Pin functions	12
8	Package and PC board thermal data	14
	8.1 VNI4140K thermal data	14
9	Reverse polarity protection	16
10	Demagnetization energy	17
11	Package mechanical data	18
12	Ordering information	23
13	Revision history	24

1 Pin connection

Figure 2. Pin connection (top view)

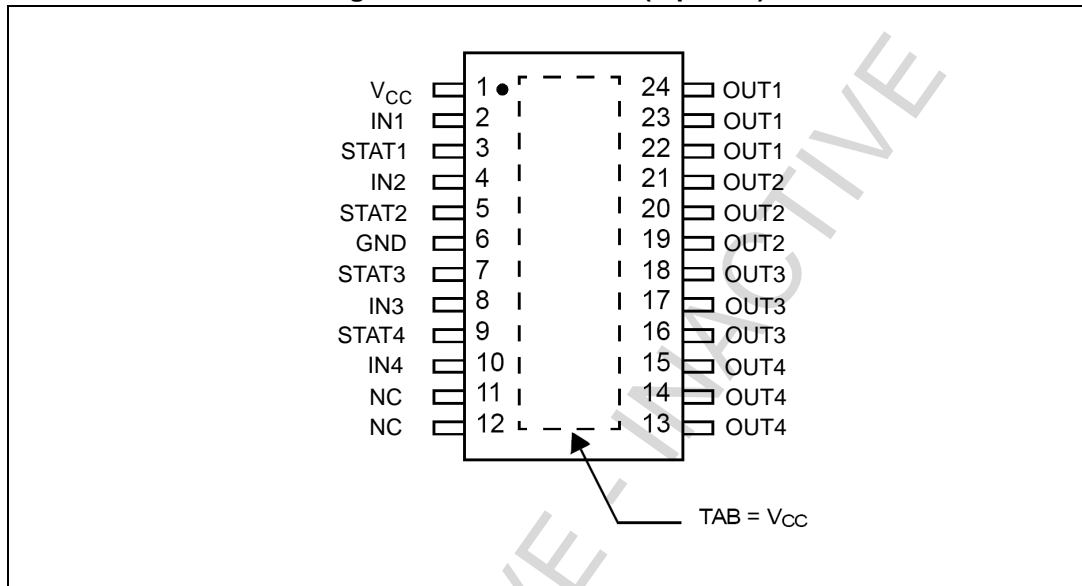

Table 1. Pin description

Pin	Name	Description
Tab	TAB	Exposed tab internally connected to V_{CC}
1	V_{CC}	Supply voltage
2	IN1	Channel 1 input 3.3 V CMOS/TTL compatible
3	STAT1	Channel 1 status in open drain configuration
4	IN2	Channel 2 input 3.3 V CMOS/TTL compatible
5	STA2	Channel 2 status in open drain configuration
6	GND	Device ground connection
7	STAT3	Channel 3 status in open drain configuration
8	IN3	Channel 3 input 3.3 V CMOS/TTL compatible
9	STAT4	Channel 4 status in open drain configuration
10	IN4	Channel 4 input 3.3 V CMOS/TTL compatible
11	NC	
12	NC	
13	OUT4	Channel 4 power stage output, internally protected
14	OUT4	Channel 4 power stage output, internally protected
15	OUT4	Channel 4 power stage output, internally protected
16	OUT3	Channel 3 power stage output, internally protected
17	OUT3	Channel 3 power stage output, internally protected

Table 1. Pin description (continued)

Pin	Name	Description
18	OUT3	Channel 3 power stage output, internally protected
19	OUT2	Channel 2 power stage output, internally protected
20	OUT2	Channel 2 power stage output, internally protected
21	OUT2	Channel 2 power stage output, internally protected
22	OUT1	Channel 1 power stage output, internally protected
23	OUT1	Channel 1 power stage output, internally protected
24	OUT1	Channel 1 power stage output, internally protected

INACTIVE - INACTIVE - INACTIVE

2 Maximum ratings

Table 2. Absolute maximum ratings

Symbol	Parameter	Value	Unit
V_{CC}	Power supply voltage	41	V
$-V_{CC}$	Reverse supply voltage	-0.3	V
I_{GND}	DC ground reverse current	-250	mA
I_{OUT}	Output current (continuous)	Internally limited	A
I_R	Reverse output current (per channel)	-5	A
I_{IN}	Input current (per channel)	± 10	mA
V_{IN}	Input voltage	$+V_{CC}$	V
V_{STAT}	Status pin voltage	$+V_{CC}$	V
I_{STAT}	Status pin current	± 10	mA
V_{ESD}	Electrostatic discharge (R = 1.5 k Ω ; C = 100 pF)	2000	V
E_{AS}	$I_{OUT} = 500$ mA $T_{AMB} = 125$ °C	5	J
P_{TOT}	Power dissipation at $T_C = 25$ °C	Internally limited	W
T_J	Junction operating temperature	Internally limited	°C
T_{STG}	Storage temperature	-55 to 150	°C

2.1 Thermal data

Table 3. Thermal data

Symbol	Parameter	Value	Unit
$R_{th(JC)}$	Thermal resistance junction-case ⁽¹⁾	Max. 2	°C/W
$R_{th(JA)}$	Thermal resistance junction-ambient	Max. see Figure 11	°C/W

1. Per channel.

3 Electrical characteristics

10.5 V < V_{CC} < 36 V; -40 °C < T_J < 125 °C; unless otherwise specified

Table 4. Power section

Symbol	Parameter	Test conditions	Min.	Typ.	Max.	Unit
V _{CC}	Supply voltage		10.5		36	V
R _{DS(on)}	On-state resistance	I _{OUT} = 0.5 A at T _J = 25 °C I _{OUT} = 0.5 A			0.080 0.140	Ω Ω
V _{clamp}		I _S = 20 mA	41	45	52	V
I _S	Supply current	All channels in OFF state ON state with V _{IN} = 5 V (T _J = 125 °C)		250 2.4	4	μA mA
I _{LGND}	Output current at turn-off	V _{CC} = V _{STAT} = V _{IN} = V _{GND} = 24 V, V _{OUT} = 0 V			1	mA
V _{OUT(OFF)}	Off state output voltage	V _{IN} = 0 V and I _{OUT} = 0 A			1	V
I _{OUT(OFF)}	Off state output current	V _{IN} = V _{OUT} = 0 V	0		5	μA
F _{CP}	Charge pump frequency	Channel in ON state ⁽¹⁾		1450		kHz

1. To cover EN55022 class A and class B normative.

V_{CC} = 24 V; -40 °C < T_J < 125 °C, R_L = 48 Ω, input rise time < 0.1 μs

Table 5. Switching

Symbol	Parameter	Min.	Typ.	Max.	Unit
t _{d(ON)}	Turn on delay	-	20	-	μs
t _r	Rise time	-	10	-	μs
t _{d(OFF)}	Turn off	-	30	-	μs
t _f	Fall time	-	8	-	μs
dV/dt _(ON)	Turn on voltage slope	-	3	-	V/μs
dV/dt _(OFF)	Turn off voltage slope	-	4	-	V/μs

Table 6. Logical input

Symbol	Parameter	Test condition	Min.	Typ.	Max.	Unit
V_{IL}	Input low level voltage				0.8	V
V_{IH}	Input high level voltage		2.20			V
$V_{I(HYST)}$	Input hysteresis voltage			0.15		V
I_{IN}	Input current	$V_{IN} = 15\text{ V}$			10	μA
		$V_{IN} = 36\text{ V}$			210	

Table 7. Protection and diagnostic

Symbol	Parameter	Test conditions	Min.	Typ.	Max.	Unit
V_{STAT}	Status voltage output low	$I_{STAT} = 1.6\text{ mA}$			0.6	V
V_{USD}	Undervoltage protection		7		10.5	V
V_{USDHYS}	Undervoltage hysteresis		0.4	0.5		V
I_{LIM}	DC short-circuit current	$V_{CC} = 24\text{ V}; R_{LOAD} < 10\text{ m}\Omega$	0.7	1	1.7	A
I_{PEAK}	Maximum DC output current	Dynamic load		1.3		A
HYST	Tracking limits			0.2		A
I_{LSTAT}	Status leakage current	$V_{CC} = V_{STAT} = 36\text{ V}$		30		μA
T_{TSD}	Junction shutdown temperature		150	170	190	$^{\circ}\text{C}$
T_R	Junction reset temperature		135			$^{\circ}\text{C}$
T_{HYST}	Junction thermal hysteresis		7	15		$^{\circ}\text{C}$
T_{CSD}	Case shutdown temperature		125	130	135	$^{\circ}\text{C}$
T_{CR}	Case reset temperature		110			$^{\circ}\text{C}$
T_{CHYST}	Case thermal hysteresis		7	15		$^{\circ}\text{C}$
V_{demag}	Output voltage at turn-off	$I_{OUT} = 0.5\text{ A}; L_{LOAD} \geq 1\text{ mH}$	$V_{CC}-41$	$V_{CC}-45$	$V_{CC}-52$	V

Figure 3. Current and voltage conventions

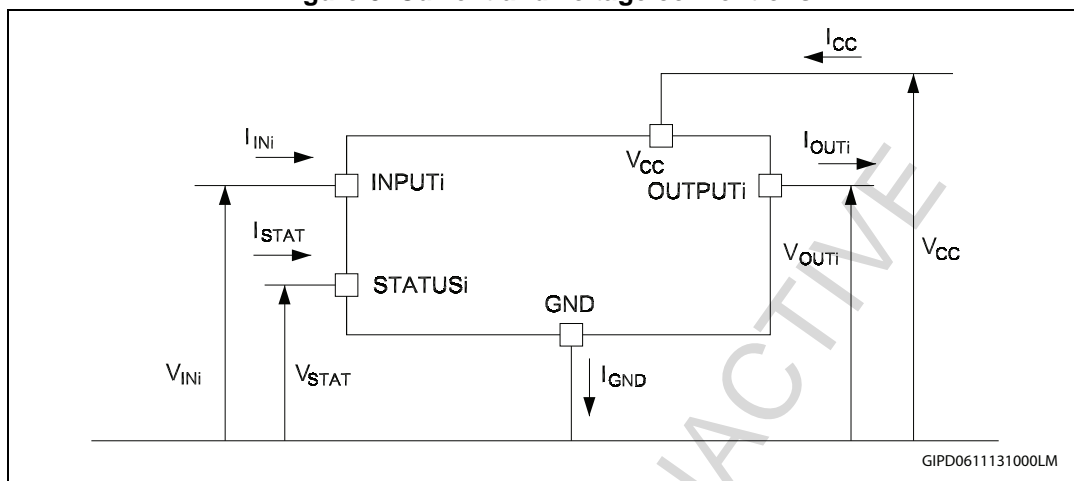

4 Truth table

Table 8. Truth table

Condition	INPUTn	OUTPUTn	STATUSn
Normal operation	L	L	H
	H	H	H
Overtemperature	L	L	H
	H	L	L
Undervoltage	L	L	X
	H	L	X
Shorted load (current limitation)	L	L	H
	H	X	H

5 Typical application circuit

Figure 4. Typical application circuit

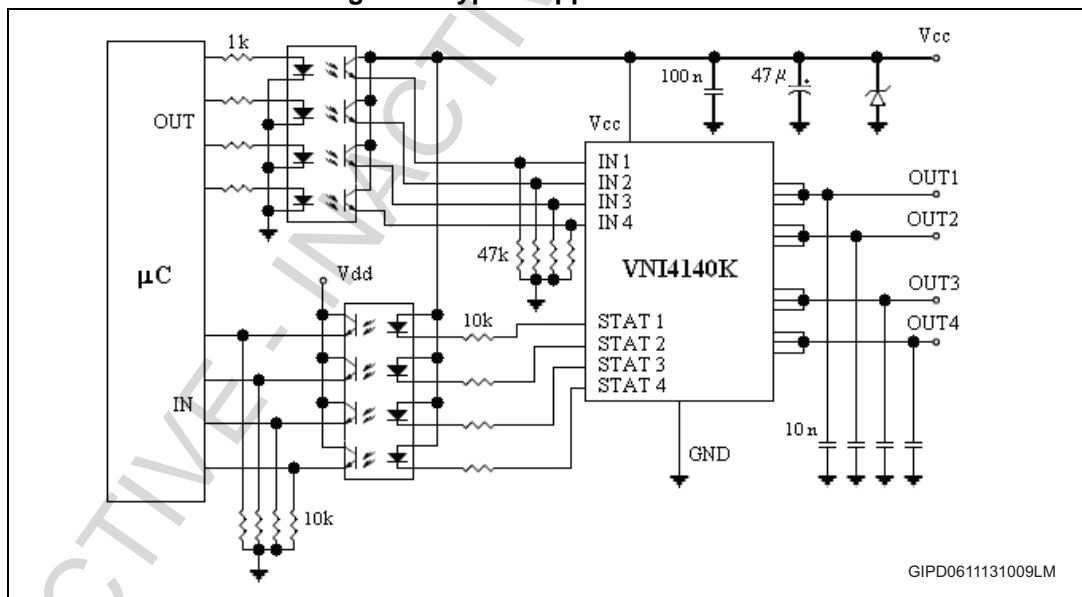
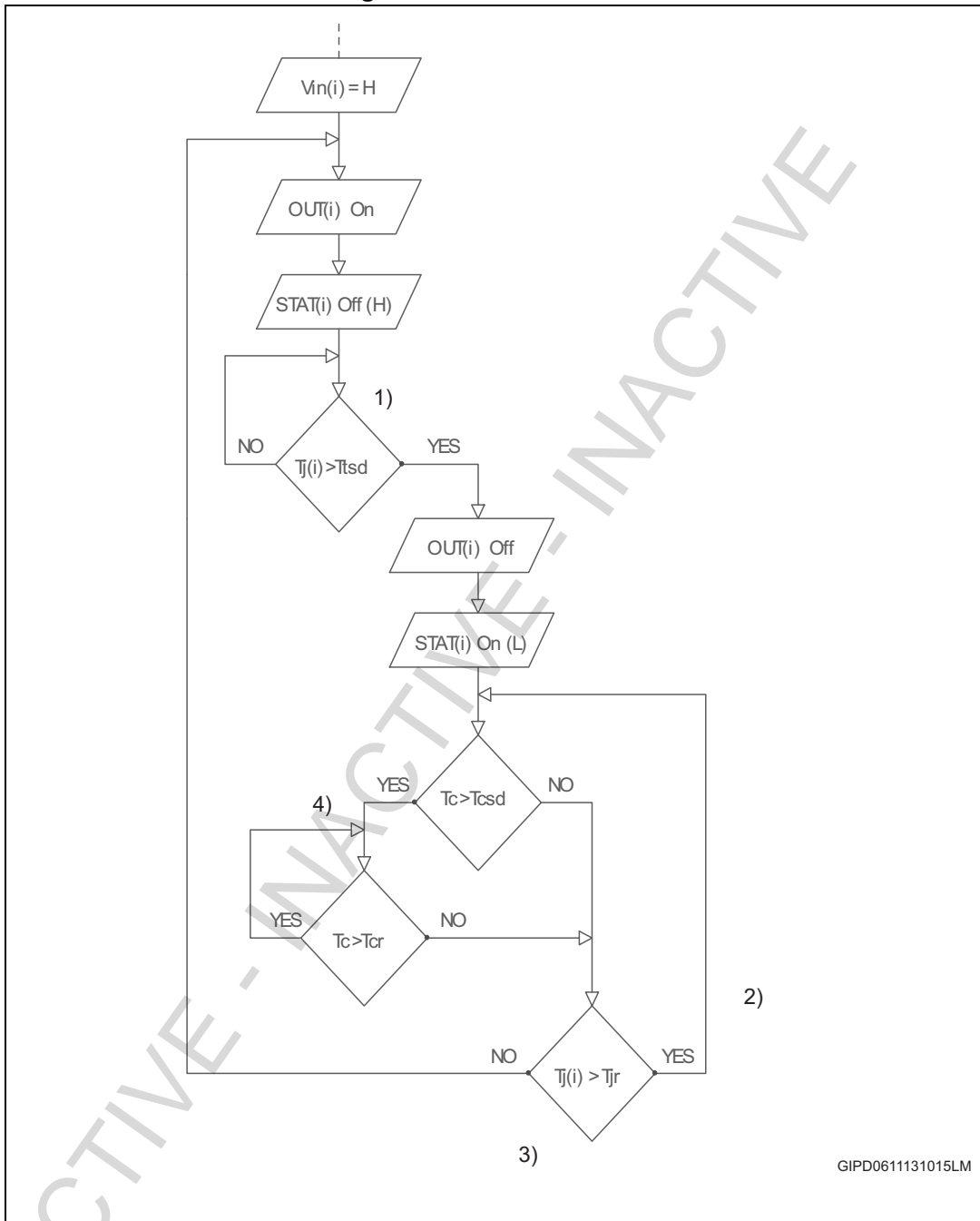
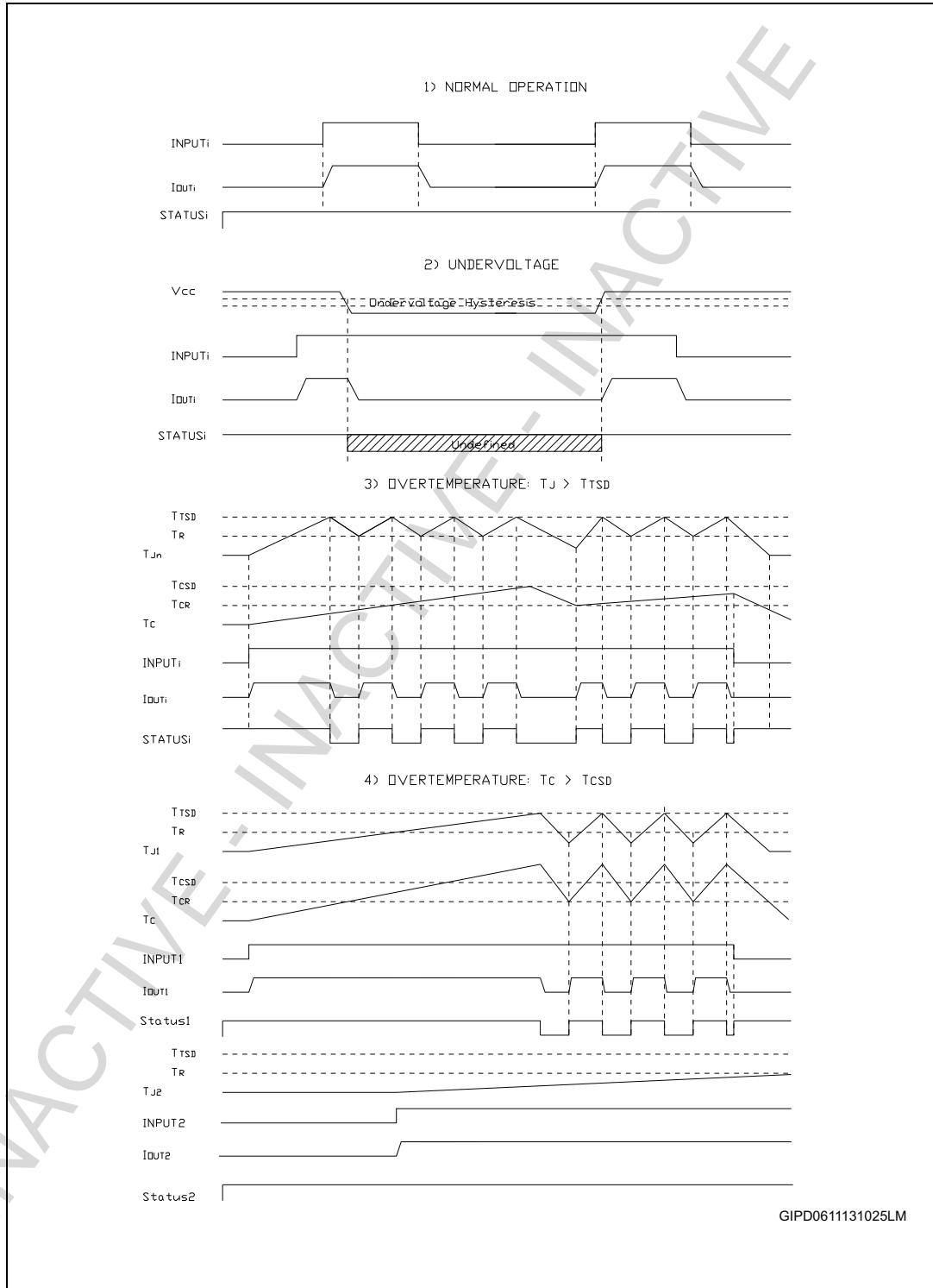

Figure 5. Thermal behavior



6 Switching waveforms

Figure 6. Switching waveforms



7 Pin functions

Figure 7. Input circuit

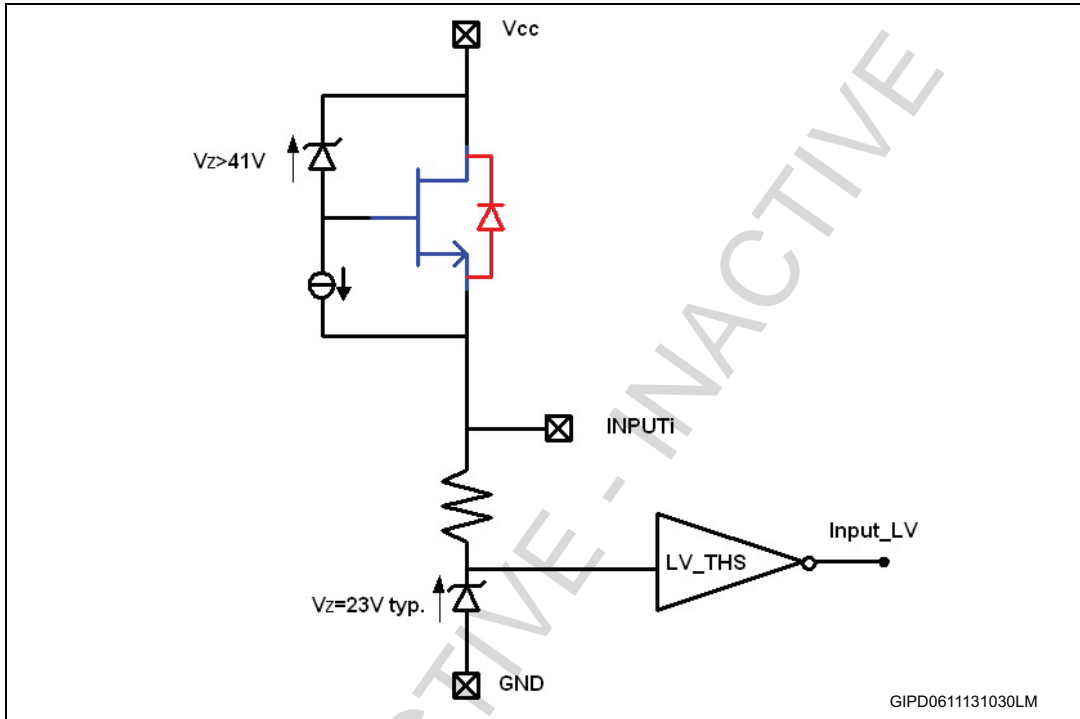

Figure 8. Status circuit

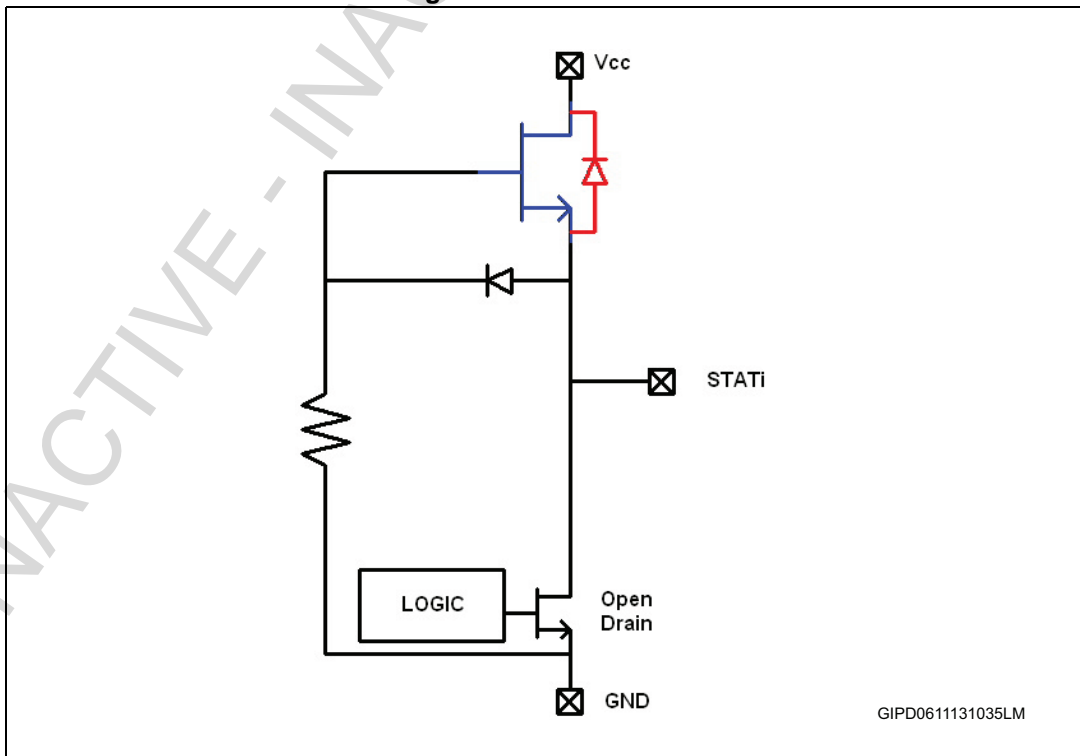
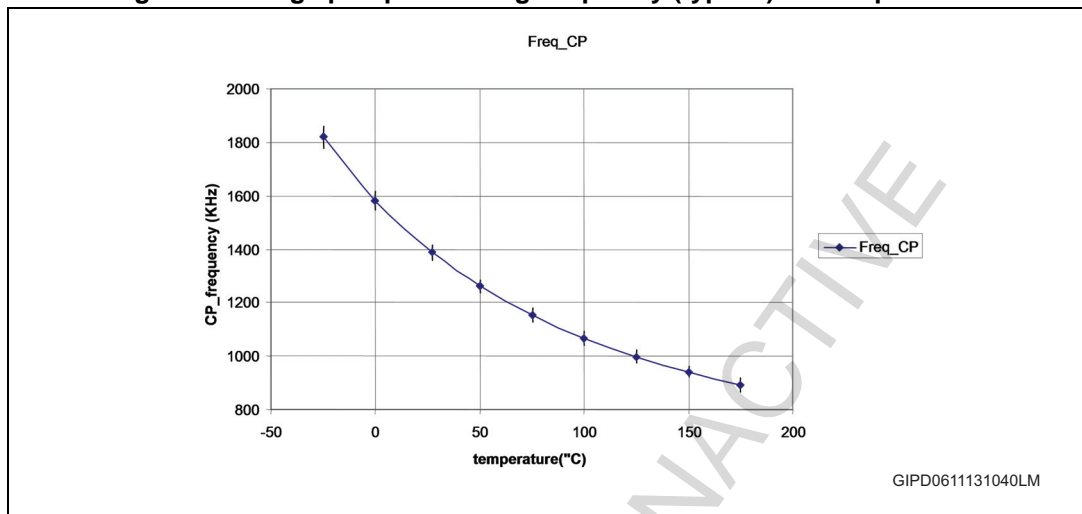

Figure 9. Charge pump switching frequency (typical) vs. temperature



8 Package and PC board thermal data

8.1 VNI4140K thermal data

Figure 10. VNI4140K PC board

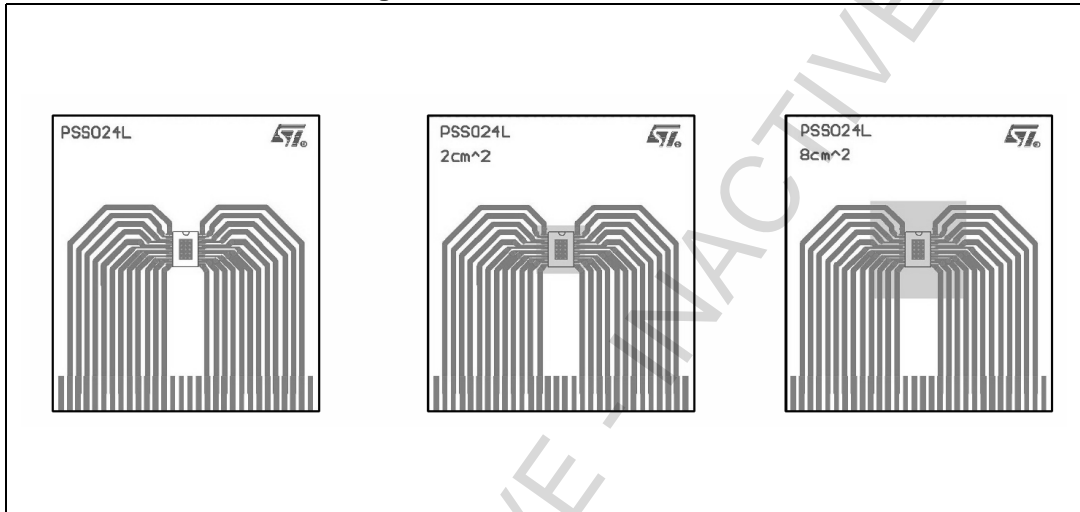

Note: Layout condition of R_{th} and Z_{th} measurements (PCB: double layer, thermal vias, FR4 area = 77 mm x 86 mm, PCB thickness = 1.6 mm, Cu thickness = 70 mm (front and back side), copper areas: from minimum pad layout to 8 cm²).

Figure 11. $R_{th(JA)}$ vs. PCB copper area in open box free air condition (one channel ON)

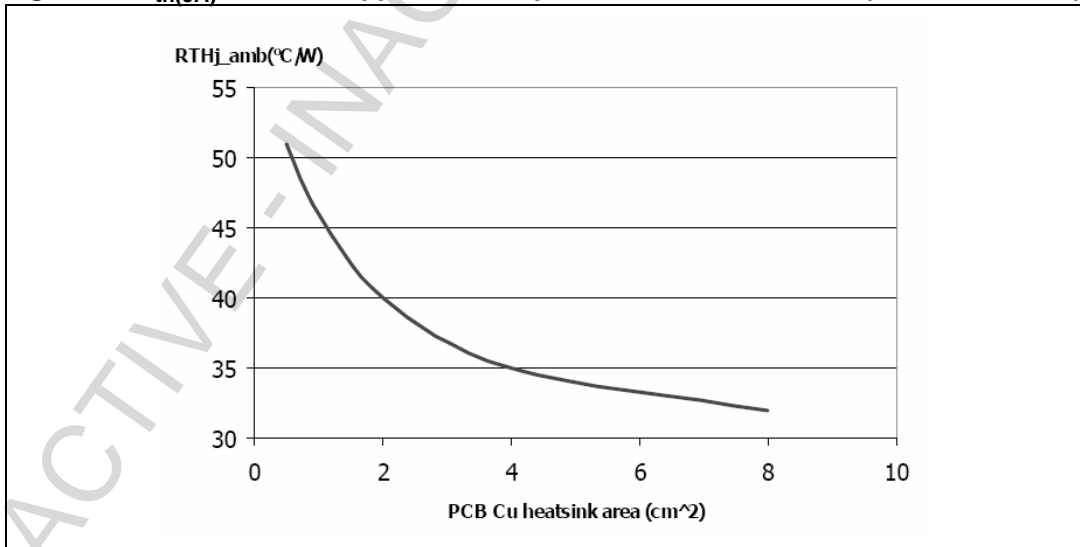
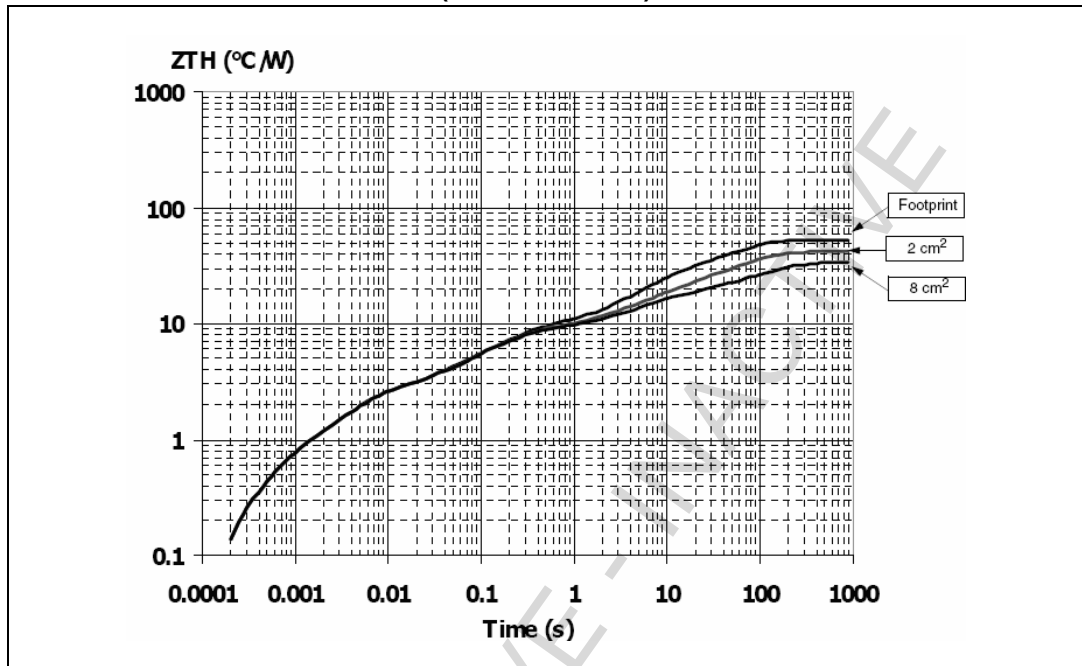

Figure 12. VNI4140K thermal impedance junction ambient single pulse (one channel on)



9 Reverse polarity protection

Reverse polarity protection can be implemented on board using two different solutions:

1. Placing a resistor (R_{GND}) between IC GND pin and load GND
2. Placing a diode between IC GND pin and load GND

If option 1 is selected, the minimum resistance value has to be selected according to the following equation:

Equation 1

$$R_{GND} \geq V_{CC}/I_{GND}$$

where I_{GND} is the DC reverse ground pin current and can be found in [Section 2: Maximum ratings](#) of this datasheet.

Power dissipated by R_{GND} (when $V_{CC} < 0$: during reverse polarity situations) is:

Equation 2

$$PD = (V_{CC})^2/R_{GND}$$

If option 2 is selected, the diode has to be chosen by taking into account $VRRM > |V_{CC}|$ and its power dissipation capability:

Equation 3

$$P_D \geq I_S \cdot V_f$$

Note: In normal conditions (no reverse polarity) due to the diode, there is a voltage drop between GND of the device and GND of the system.

Figure 13. Reverse polarity protection

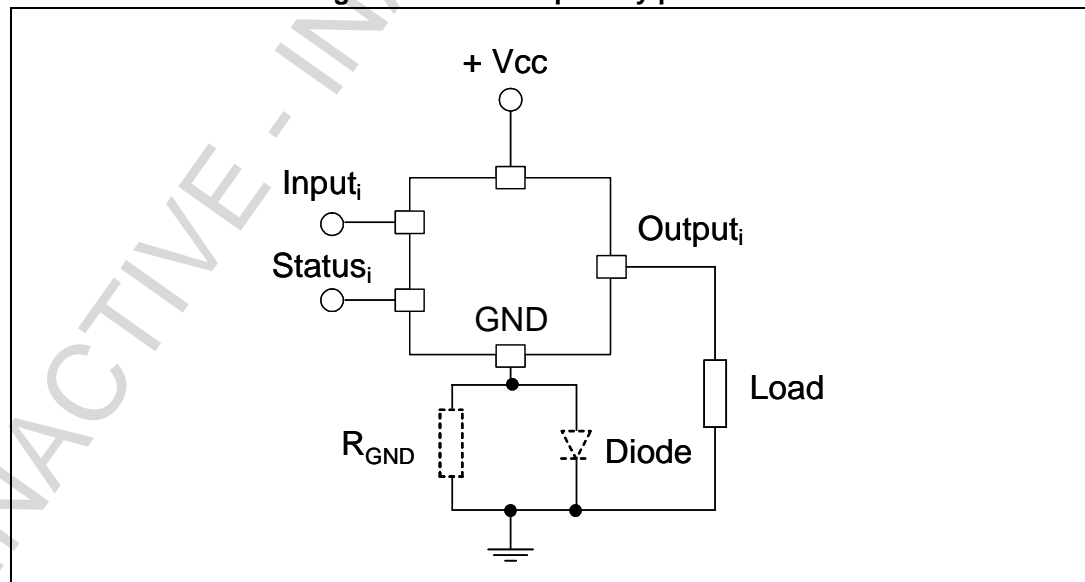

This schematic can be used with any type of load.

10 Demagnetization energy

Figure 14. Maximum demagnetization energy vs. load current, typical values

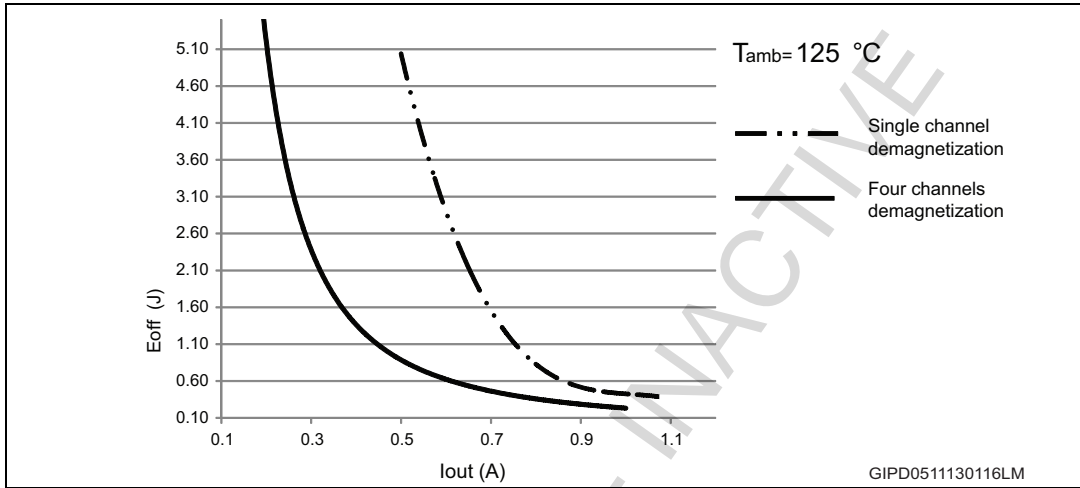

11 Package mechanical data

In order to meet environmental requirements, ST offers these devices in different grades of ECOPACK[®] packages, depending on their level of environmental compliance. ECOPACK[®] specifications, grade definitions and product status are available at: www.st.com. ECOPACK[®] is an ST trademark.

Table 9. PowerSSO-24 mechanical data

Symbol	mm		
	Min.	Typ.	Max.
A	2.15		2.47
A2	2.15		2.40
a1	0		0.075
b	0.33		0.51
c	0.23		0.32
D	10.10		10.50
E	7.4		7.6
e		0.8	
e3		8.8	
G			0.1
G1			0.06
H	10.1		10.5
h			0.4
L	0.55		0.85
N			10deg
X	4.1		4.7
Y	6.5		7.1

Figure 15. PowerSSO-24 package dimensions

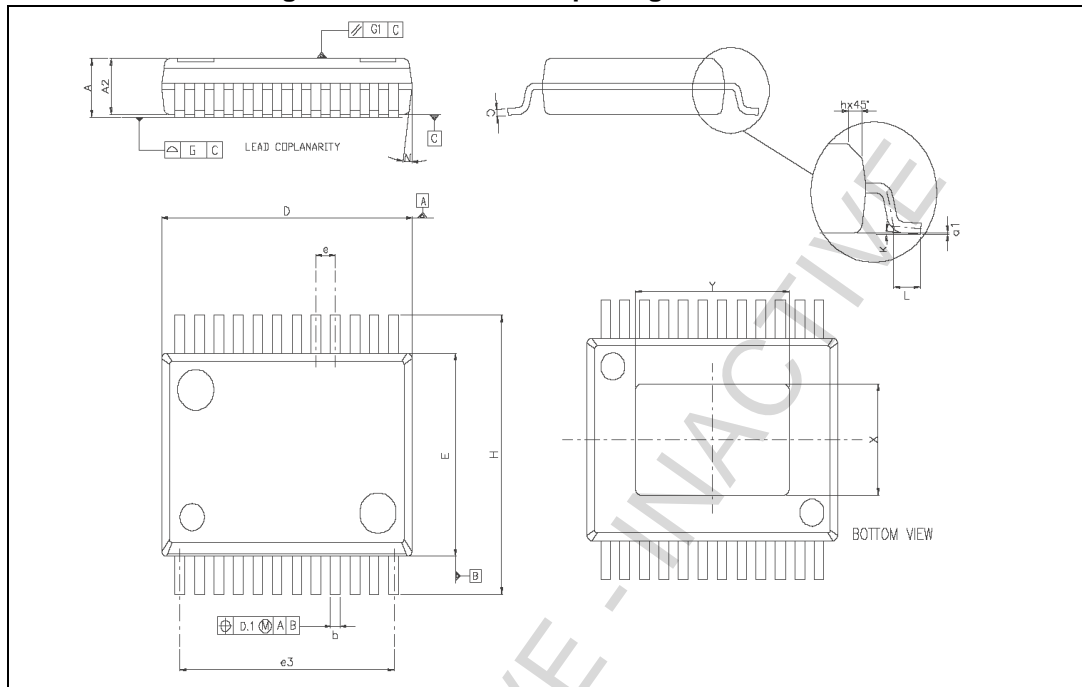

Figure 16. PowerSSO-24 tube shipment (no suffix)

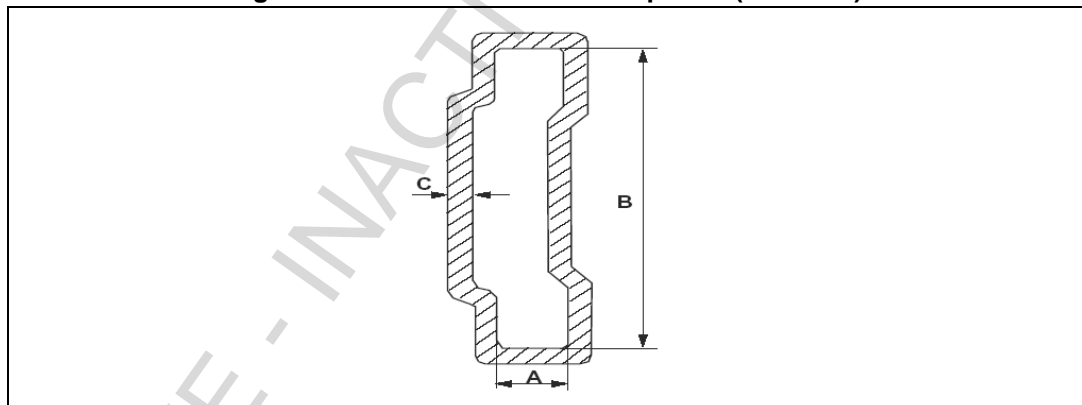

Table 10. PowerSSO-24 tube shipment

Base quantity	49
Bulk quantity	1225
Tube length (± 0.5)	532
A	3.5
B	13.8
C (± 0.1)	0.6

Note: All dimensions are in mm.

Figure 17. PowerSSO-24 reel shipment (suffix "TR")

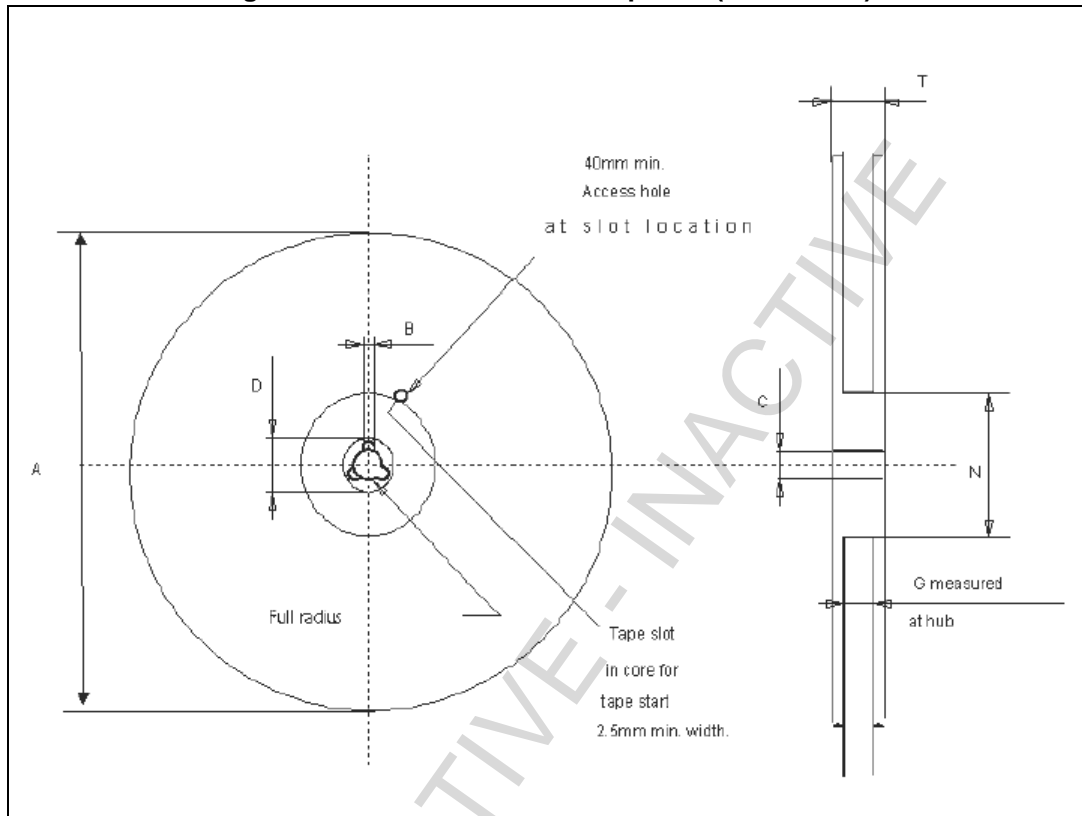

Table 11. PowerSSO-24 reel dimensions

Base quantity	1000
Bulk quantity	1000
A (max.)	330
B (min.)	1.5
C (± 0.2)	13
F	20.2
G (2 ± 0)	24.4
N (min.)	100
T (max.)	30.4

Figure 18. PowerSSO-24™ tape dimensions

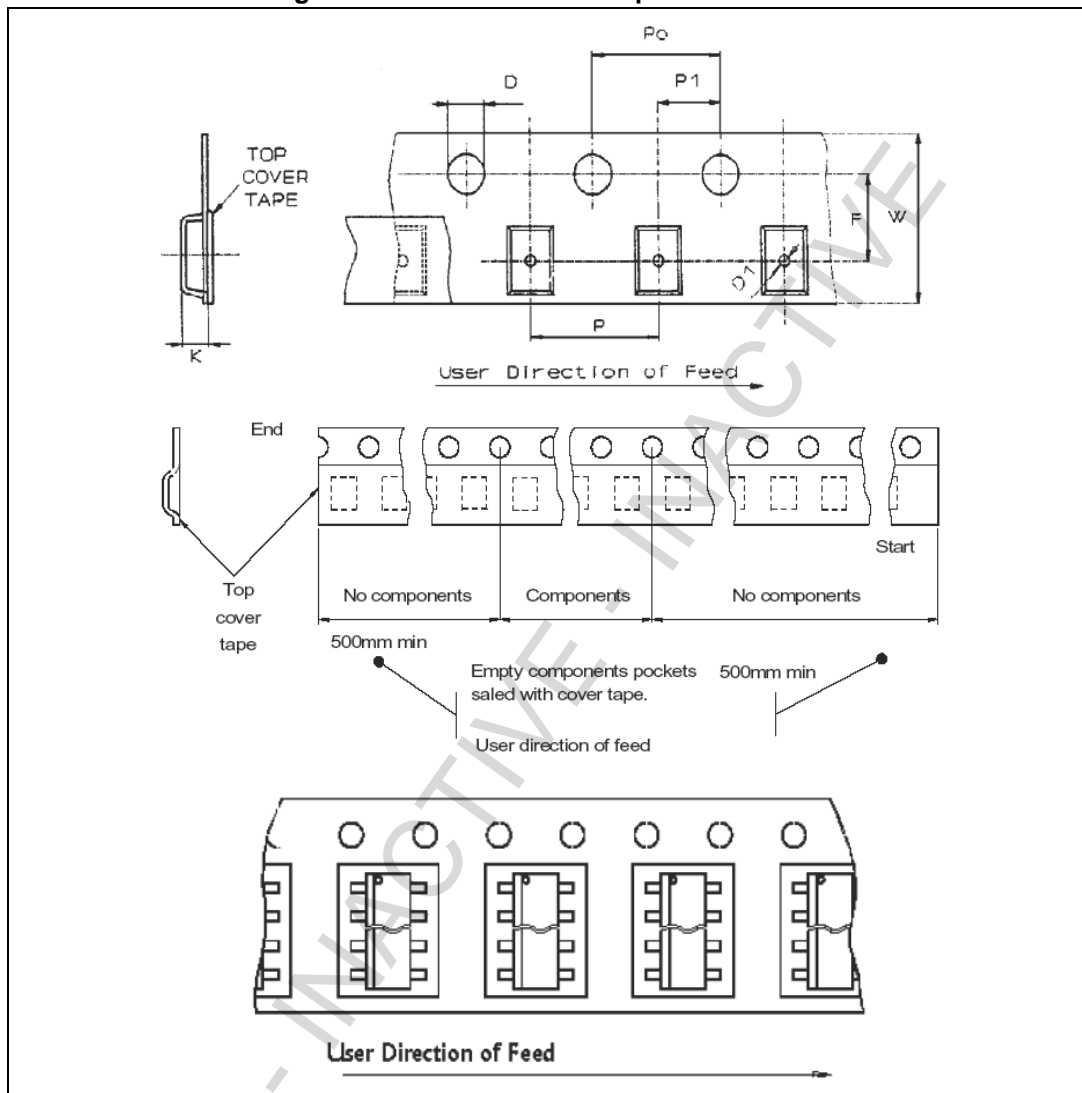

Table 12. PowerSSO-24™ tape dimensions

Tape width	W	24
Tape hole spacing	$P_0 (\pm 0.1)$	4
Component spacing	P	12
Hole diameter	$D (\pm 0.05)$	1.55
Hole diameter	D1 (min.)	1.5
Hole position	$F (\pm 0.1)$	11.5
Compartment depth	K (max.)	2.85
Hole spacing	$P_1 (\pm 0.1)$	2

Note: According to Electronic Industries Association (EIA) Standard 481 rev. A, Feb 1986

12 Ordering information

Table 13. Order code

Order code	Package	Packaging
VNI4140K	PowerSSO-24	Tube
VNI4140KTR	PowerSSO-24	Tape and reel

INACTIVE - INACTIVE - INACTIVE

13 Revision history

Table 14. Document revision history

Date	Revision	Changes
16-Nov-2007	1	Initial release.
26-Nov-2007	2	Updated electrical parameters values.
08-Jul-2008	3	Inserted: Figure 4 on page 9 and Section 9: Reverse polarity protection on page 16 .
08-Apr-2008	4	Added I_{LGND} parameter in Table 4 on page 6 .
27-Aug-2009	5	Updated Section 9: Reverse polarity protection .
09-Dec-2009	6	Added Section 10: Conformity to IEC 61000-4-2 ESD immunity test .
15-Apr-2010	7	Updated Table 5 on page 6 .
06-Feb-2012	8	Inserted feature: conformity to IEC 61000-4-2 ESD immunity test in cover page. Removed chapter: conformity to IEC 61000-4-2 ESD immunity test.
05-Mar-2012	9	Suggested footprint inserted. In Table 4 parameter I_{LGND} has been added.
19-Mar-2012	10	Minor text changes.
20-Dec-2012	11	Operating temperature range extended.
06-Nov-2013	12	Updated E_{AS} value in Table 2: Absolute maximum ratings . Added Figure 14 .
11-Dec-2013	13	Updated Section 9 .

Please Read Carefully:

Information in this document is provided solely in connection with ST products. STMicroelectronics NV and its subsidiaries ("ST") reserve the right to make changes, corrections, modifications or improvements, to this document, and the products and services described herein at any time, without notice.

All ST products are sold pursuant to ST's terms and conditions of sale.

Purchasers are solely responsible for the choice, selection and use of the ST products and services described herein, and ST assumes no liability whatsoever relating to the choice, selection or use of the ST products and services described herein.

No license, express or implied, by estoppel or otherwise, to any intellectual property rights is granted under this document. If any part of this document refers to any third party products or services it shall not be deemed a license grant by ST for the use of such third party products or services, or any intellectual property contained therein or considered as a warranty covering the use in any manner whatsoever of such third party products or services or any intellectual property contained therein.

UNLESS OTHERWISE SET FORTH IN ST'S TERMS AND CONDITIONS OF SALE ST DISCLAIMS ANY EXPRESS OR IMPLIED WARRANTY WITH RESPECT TO THE USE AND/OR SALE OF ST PRODUCTS INCLUDING WITHOUT LIMITATION IMPLIED WARRANTIES OF MERCHANTABILITY, FITNESS FOR A PARTICULAR PURPOSE (AND THEIR EQUIVALENTS UNDER THE LAWS OF ANY JURISDICTION), OR INFRINGEMENT OF ANY PATENT, COPYRIGHT OR OTHER INTELLECTUAL PROPERTY RIGHT.

ST PRODUCTS ARE NOT DESIGNED OR AUTHORIZED FOR USE IN: (A) SAFETY CRITICAL APPLICATIONS SUCH AS LIFE SUPPORTING, ACTIVE IMPLANTED DEVICES OR SYSTEMS WITH PRODUCT FUNCTIONAL SAFETY REQUIREMENTS; (B) AERONAUTIC APPLICATIONS; (C) AUTOMOTIVE APPLICATIONS OR ENVIRONMENTS, AND/OR (D) AEROSPACE APPLICATIONS OR ENVIRONMENTS. WHERE ST PRODUCTS ARE NOT DESIGNED FOR SUCH USE, THE PURCHASER SHALL USE PRODUCTS AT PURCHASER'S SOLE RISK, EVEN IF ST HAS BEEN INFORMED IN WRITING OF SUCH USAGE, UNLESS A PRODUCT IS EXPRESSLY DESIGNATED BY ST AS BEING INTENDED FOR "AUTOMOTIVE, AUTOMOTIVE SAFETY OR MEDICAL" INDUSTRY DOMAINS ACCORDING TO ST PRODUCT DESIGN SPECIFICATIONS. PRODUCTS FORMALLY ESCC, QML OR JAN QUALIFIED ARE DEEMED SUITABLE FOR USE IN AEROSPACE BY THE CORRESPONDING GOVERNMENTAL AGENCY.

Resale of ST products with provisions different from the statements and/or technical features set forth in this document shall immediately void any warranty granted by ST for the ST product or service described herein and shall not create or extend in any manner whatsoever, any liability of ST.

ST and the ST logo are trademarks or registered trademarks of ST in various countries.

Information in this document supersedes and replaces all information previously supplied.

The ST logo is a registered trademark of STMicroelectronics. All other names are the property of their respective owners.

© 2013 STMicroelectronics - All rights reserved

STMicroelectronics group of companies

Australia - Belgium - Brazil - Canada - China - Czech Republic - Finland - France - Germany - Hong Kong - India - Israel - Italy - Japan - Malaysia - Malta - Morocco - Philippines - Singapore - Spain - Sweden - Switzerland - United Kingdom - United States of America

www.st.com

