

**15W STEREO CLASS-D AUDIO POWER AMPLIFIER WITH POWER LIMIT**

**Description**

The PAM8006A is a 15W (per channel) stereo Class-D audio amplifier which offers low THD+N (0.2%), low EMI and good PSRR thus high quality sound reproduction.

The PAM8006A runs off of an 8V to 18V supply at much higher efficiency than competitors' ICs.

The PAM8006A only requires very few external components, significantly saving cost and board space.

The PAM8006A is available in a QFN5x5-32L package.

**Features**

- 15W x2 into a 8Ω speaker
- Low Noise: -90dB
- Over 90% Efficiency
- With Shutdown/Mute Function
- Over Current ,OVP,UVLO,Thermal and Short-Circuit Protection
- Low THD+N
- Power Limit with Non-Clip
- Low Quiescent Current
- Pop Noise Suppression
- Small Package Outlines: QFN5x5-32L
- Pb-Free Package (RoHS Compliant)

**Pin Assignments**

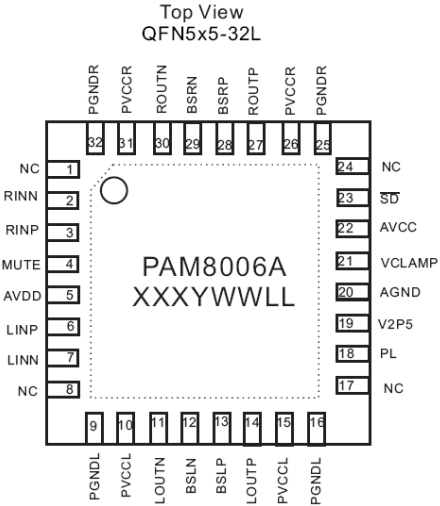

**Applications**

- Flat Monitor /LCD TVs
- Multi-Media Speaker System
- DVD Players, Game Machines
- Boom Box
- Music Instruments

**Typical Applications Circuit**

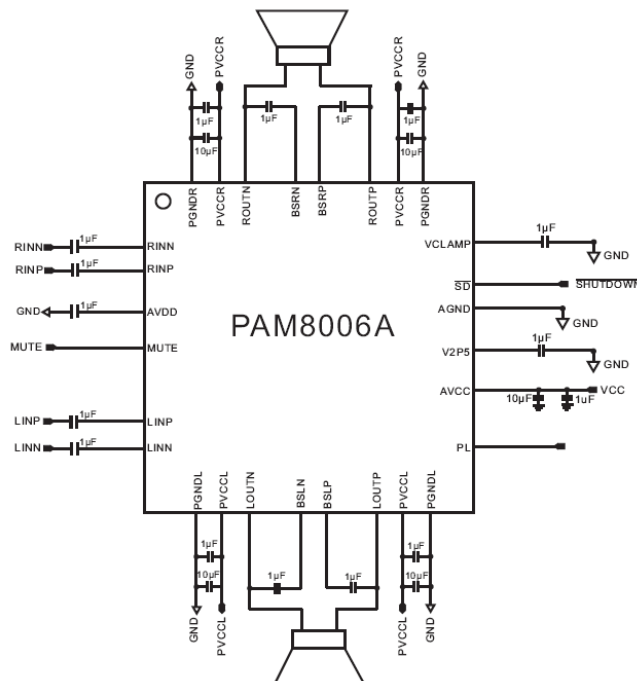

## Pin Descriptions

Pin Number	Package Name	Function
1, 8, 17, 24	NC	Not Connected
2	RINN	Negative differential audio input for right channel.
3	RINP	Positive differential audio input for right channel.
4	MUTE	A logic high on this pin disables the outputs and a logic low enables the outputs.
5	AVDD	5V Analog Supply
6	LINP	Positive differential audio input for left channel.
7	LINN	Negative differential audio input for left channel.
9, 16	PGNDL	Power ground for left channel H-bridge.
10, 15	PVCCL	Power supply for left channel H-bridge, not connected to PVCCR or AVCC.
11	LOUTN	Class-D 1/2-H-bridge negative output for left channel.
12	BSLN	Bootstrap I/O for left channel, negative high-side FET.
13	BSLP	Bootstrap I/O for left channel, positive high-side FET.
14	LOUTP	Class-D 1/2-H-bridge positive output for left channel.
18	PL	Reference voltage for power limit function.
19	V2P5	2.5V Reference for analog cells.
20	AGND	Analog Ground
21	VCLAMP	Internally generated voltage supply for bootstrap capacitors.
22	AVCC	High-voltage analog power supply (8V to 26V)
23	$\overline{SD}$	Shutdown signal for IC (low= shutdown, high = operational). TTL logic levels with compliance to $V_{CC}$ .
25, 32	PGNDR	Power ground for right channel H-bridge.
26, 31	PVCCR	Power supply for right channel H-bridge, not connected to PVCCL or AVCC.
27	ROUTP	Class-D 1/2-H-bridge positive output for right channel.
28	BSRP	Bootstrap I/O for right channel, positive high-side FET.
29	BSRN	Bootstrap I/O for right channel, negative high-side FET.
30	ROUTN	Class-D 1/2-H-bridge negative output for right channel.
33	Thermal Pad	Connect to ground. Thermal pad should be soldered down on all applications to secure the device properly to the printed wiring board.

**Functional Block Diagram**

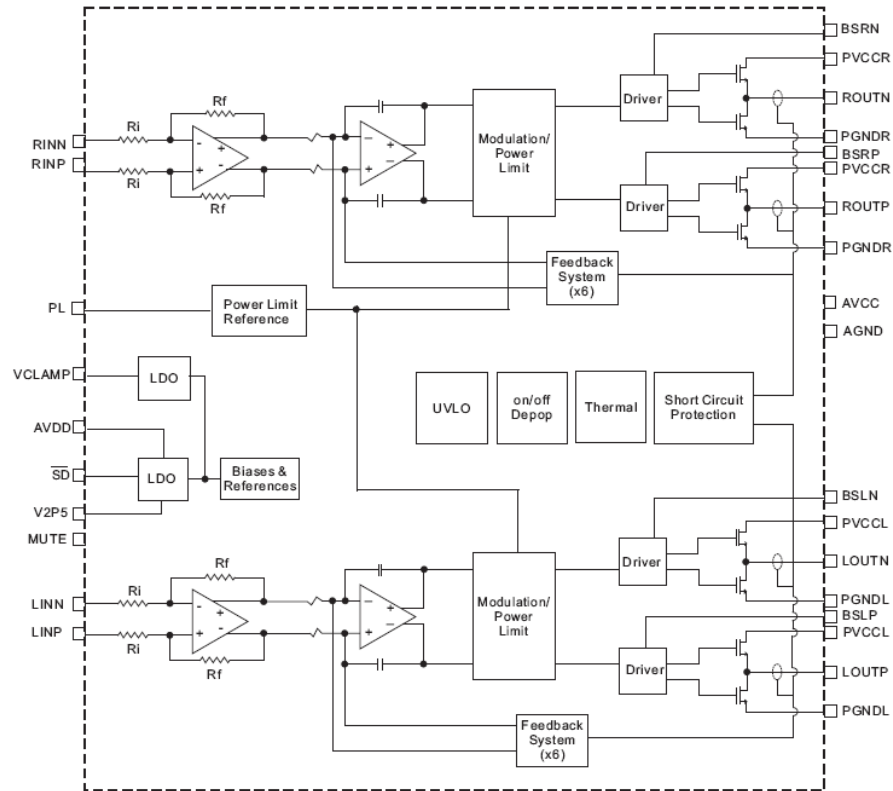

Notes: Maximum Gain:  $R_i = 12.5k$ ,  $R_f = 100k$ ;  
Power Limit Function:  $R_i$  and  $R_f$  are adjustable.

**Absolute Maximum Ratings** (@ $T_A = +25^\circ C$ , unless otherwise specified.)

These are stress ratings only and functional operation is not implied. Exposure to absolute maximum ratings for prolonged time periods may affect device reliability. All voltages are with respect to ground.

Parameter	Rating	Unit
Supply Voltage $V_{CC}$	-0.3 to +28.0	V
Input Voltage Range $V_i$ :		
MUTE, PL	0 to 6.0	V
$\overline{SD}$	-0.3 to $V_{CC}$	V
RINN, RINP, LINN, LINP	-0.3 to +6.0	V
Junction Temperature Range, $T_J$	-40 to +125	$^\circ C$
Storage Temperature	-65 to +150	$^\circ C$
Lead Temperature 1, 6mm (1/16inch)	260 (5sec)	$^\circ C$

## Recommended Operating Conditions (@T<sub>A</sub> = +25°C, unless otherwise specified.)

Parameter	Rating	Unit
Supply Voltage V <sub>CC</sub>	8 to 18	V
Input Pin Voltage	0 to 5.5	V
High Level Input Voltage: $\overline{SD}$	2.0 to V <sub>CC</sub>	V
MUTE	2.0 to 5.5	V
Low Level Input Voltage: $\overline{SD}$	0 to 0.3	V
MUTE	0 to 0.3	V
Ambient Operating Temperature	-20 to +85	°C

## Thermal Information

Parameter	Package	Symbol	Maximum	Unit
Thermal Resistance (Junction to Case)	QFN5x5-32L	$\theta_{JC}$	5.0	°C/W
Thermal Resistance (Junction to Ambient)	QFN5x5-32L	$\theta_{JA}$	16.1	

The exposed PAD must be soldered to a thermal land on the PCB.

## Electrical Characteristics (@T<sub>A</sub> = +25°C, V<sub>CC</sub> = 12V, R<sub>L</sub> = 8Ω, unless otherwise specified.)

Symbol	Parameter	Conditions	Min	Typ	Max	Units
P <sub>O</sub>	Continuous Output Power	THD+N = 0.12%, f = 1kHz, R <sub>L</sub> = 8Ω		6		W
		THD+N = 1%, f = 1kHz, R <sub>L</sub> = 8Ω		8.5		
		THD+N = 10%, f = 1kHz, R <sub>L</sub> = 8Ω		10		
I <sub>DD</sub>	Quiescent Current	(No Load)		16.5	25	mA
I <sub>SD</sub>	Supply Quiescent Current in Shutdown Mode	Shutdown = 0V		4	10	μA
R <sub>DS(ON)</sub>	Drain-Source On-State Resistance	I <sub>O</sub> = 0.5A T <sub>J</sub> = +25°C	High Side	210		mΩ
			Low Side	210		
			Total	420		
PSRR	Power Supply Ripple Rejection Ratio	1V <sub>PP</sub> Ripple, f = 1kHz, Inputs AC-Coupled to Ground		-65		dB
f <sub>OSC</sub>	Oscillator frequency			300		kHz
V <sub>n</sub>	Output Integrated Noise Floor	20Hz to 22kHz, A-Weighting		-100		dB
CS	Crosstalk	P <sub>O</sub> = 3W, R <sub>L</sub> = 8Ω, f = 1kHz		-95		dB
SNR	Signal to Noise Ratio	Maximum Output at THD+N < 0.5%, f = 1kHz		90		dB
	Gain			32		dB
V <sub>OSI</sub>	Output Offset Voltage (measured differentially)	INN and INP Connected Together		30		mV
V <sub>2P5</sub>	2.5V Bias Voltage	No Load		2.5		V
AVDD	Internal Analog Supply Voltage	V <sub>CC</sub> = 8V to 26V		5	5.5	V
OTS	Over Temperature Shutdown			160		°C
OTH	Thermal Hysteresis			50		°C

**Electrical Characteristics** (@ $T_A = +25^\circ\text{C}$ ,  $V_{CC} = 18\text{V}$ ,  $R_L = 8\Omega$ , unless otherwise specified.)

Symbol	Parameter	Conditions	Min	Typ	Max	Units
P <sub>O</sub>	Continuous Output Power	THD+N = 0.12%, f = 1kHz, R <sub>L</sub> = 8Ω		2.2		W
		THD+N = 0.18%, f = 1kHz, R <sub>L</sub> = 8Ω		15		
THD+N	Total Harmonic Distortion plus Noise	P <sub>O</sub> = 10W, f = 1kHz, R <sub>L</sub> = 8Ω		0.28		%
I <sub>DD</sub>	Quiescent Current	(No Load)		18	25	mA
I <sub>SD</sub>	Supply Quiescent Current in Shutdown Mode	Shutdown = 0V			50	μA
R <sub>DS(ON)</sub>	Drain-Source On-State Resisittance	I <sub>O</sub> = 0.5A T <sub>J</sub> = +25°C	High Side	210		mΩ
			Low Side	210		
			Total	420		
PSRR	Power Supply Ripple Rejection Ratio	1V <sub>PP</sub> Ripple, f = 1kHz, Inputs AC-Coupled to Ground		-65		dB
f <sub>OSC</sub>	Oscillator Frequency			300		kHz
V <sub>n</sub>	Output Integrated Noise Floor	20Hz to 22kHz, A-Weighting		-100		dB
CS	Crosstalk	P <sub>O</sub> = 3W, R <sub>L</sub> = 8Ω, f = 1kHz		-95		dB
SNR	Signal to Noise Ratio	Maximum Output at THD+N < 0.5%, f = 1kHz		90		dB
	Gain			32		dB
V <sub>OS</sub>	Output Offset Voltage (measured differentially)	INN and INP Connected Together		30		mV
V <sub>2P5</sub>	2.5V Bias Voltage	No Load		2.5		V
AVDD	Internal Analog Supply Voltage	V <sub>CC</sub> = 8V to 26V		5	5.5	V
OTS	Over Temperature Shutdown			160		°C
OTH	Thermal Hysteresis			50		°C

**Typical Performance Characteristics**

( $V_{CC} = 18$ ,  $R_L = 8\Omega$ ,  $G_V = 32dB$ ,  $T_A = +25^\circ C$ ,  $V_{CC} = 12V$ ,  $R_L = 8\Omega$ , unless otherwise specified.)

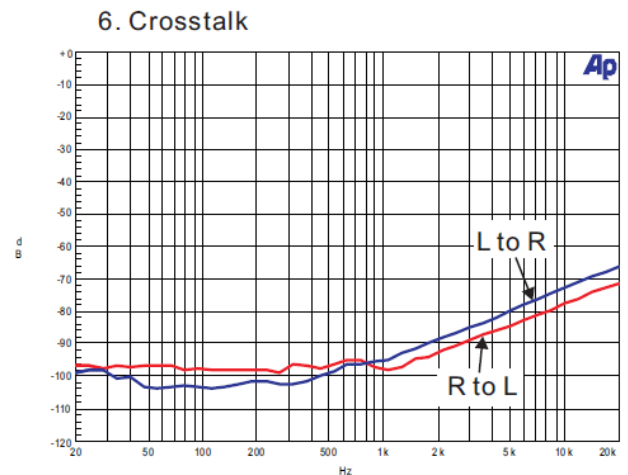
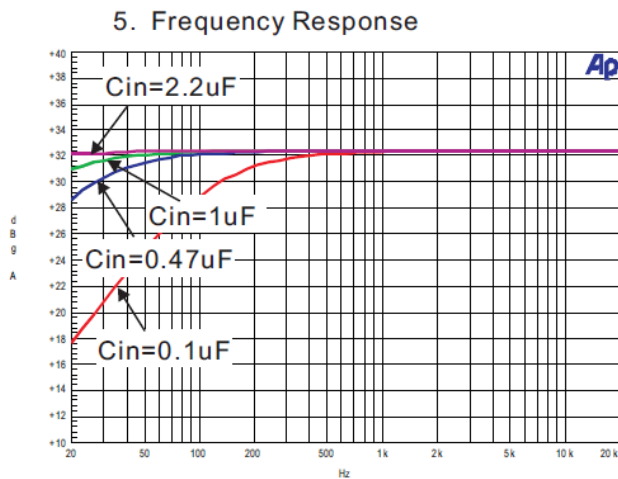
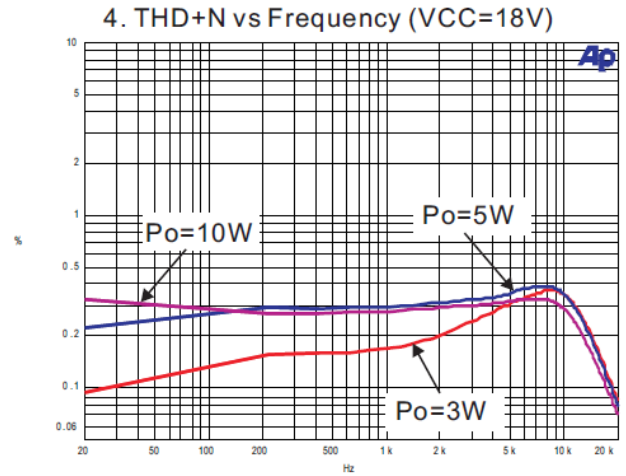
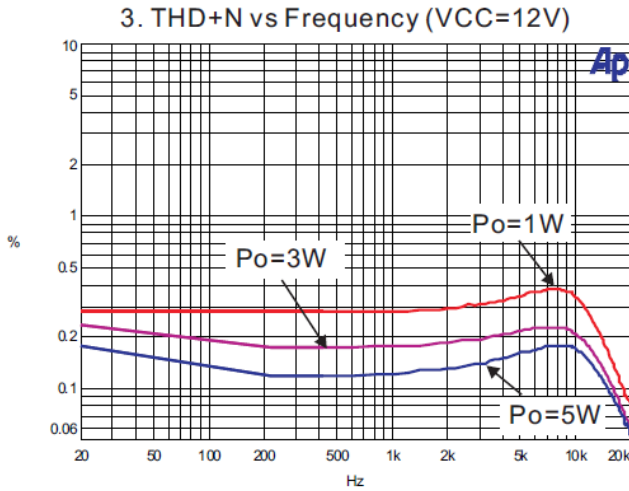
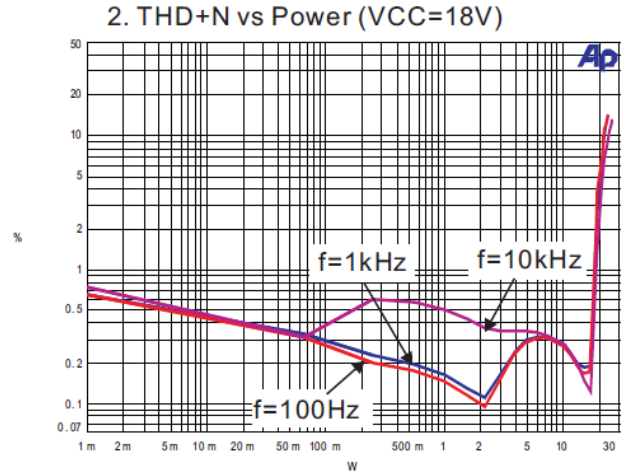
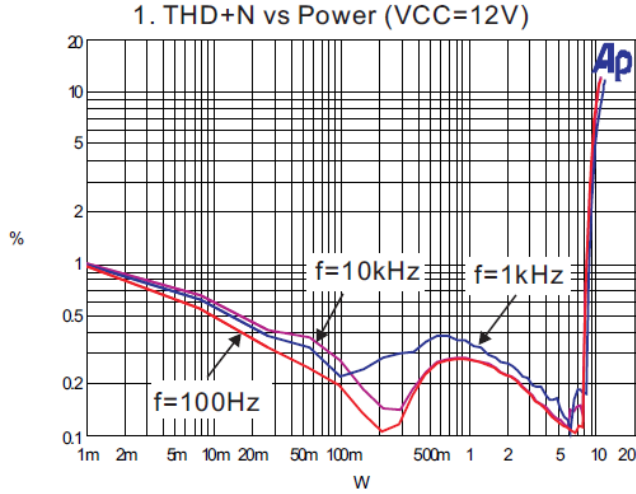

**Typical Performance Characteristics (cont.)**

( $V_{CC} = 18$ ,  $R_L = 8\Omega$ ,  $G_V = 32\text{dB}$ ,  $T_A = +25^\circ\text{C}$ ,  $V_{CC} = 12\text{V}$ ,  $R_L = 8\Omega$ , unless otherwise specified.)

7. PSRR

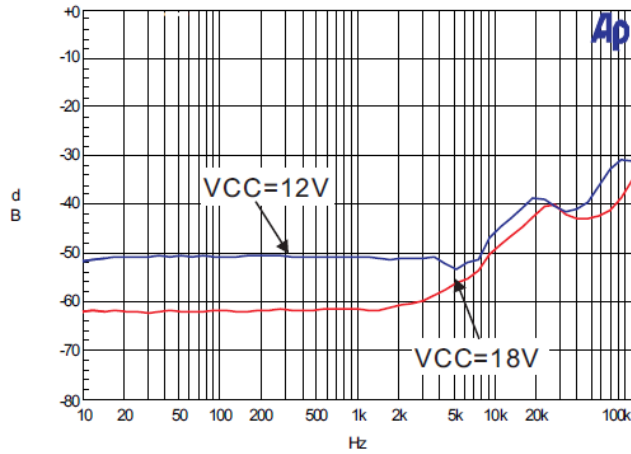

8. Noise Floor

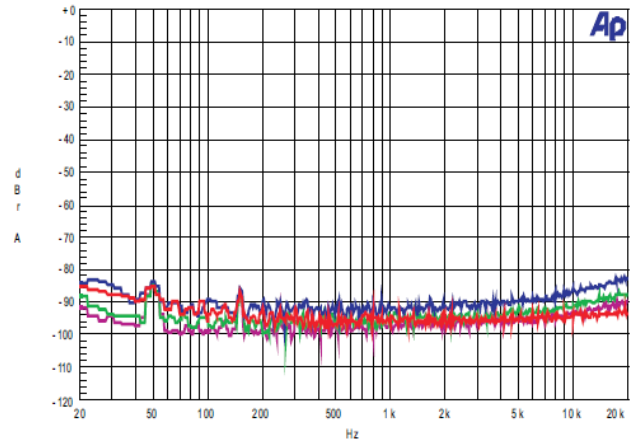

9. Efficiency vs Output Power (VCC=12V)

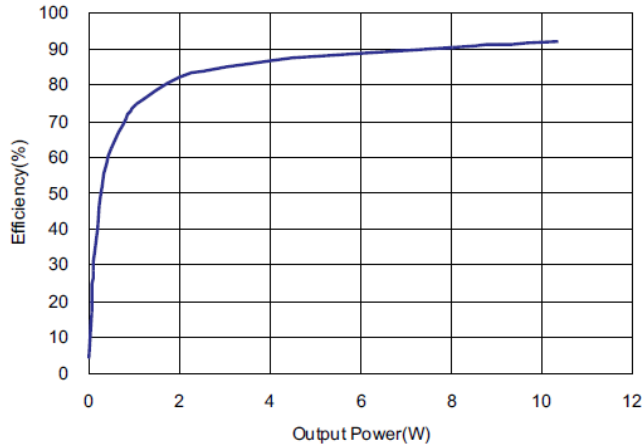

10. Efficiency vs Output Power (VCC=18V)

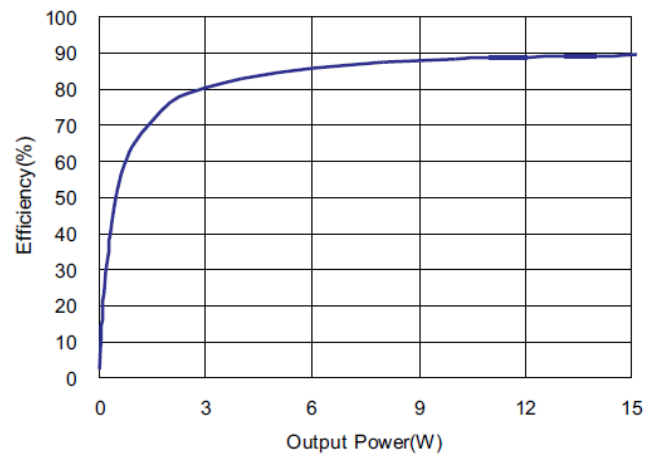

11. PL Voltage vs Output Power

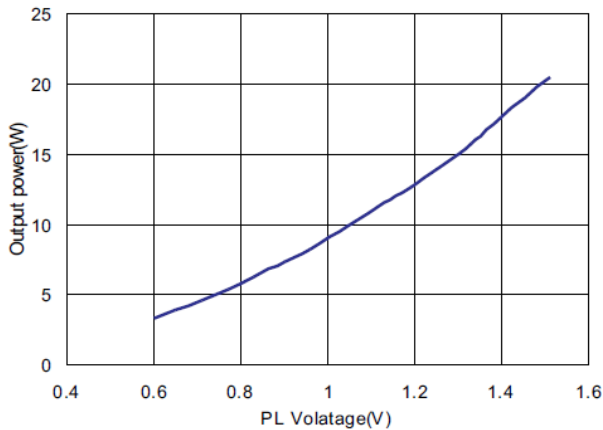

12. Quiescent Current vs Supply Voltage

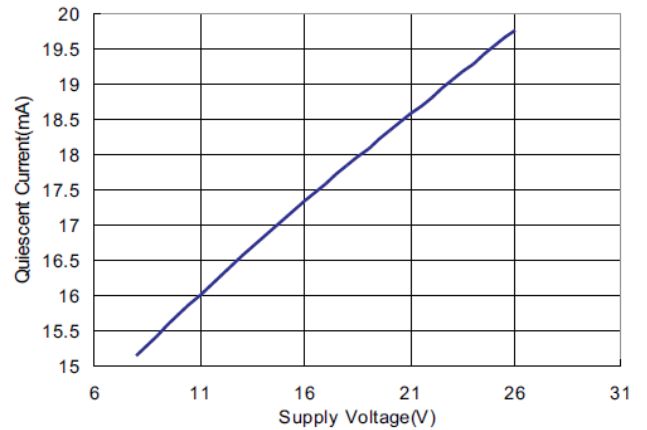

## Application Information

### Test Setup for Performance Testing

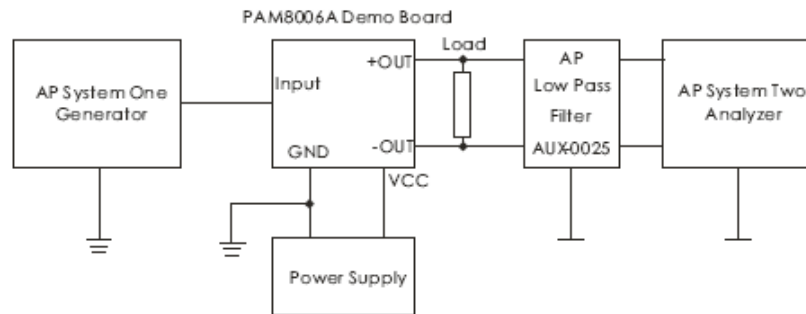

- Notes:
1. The AP AUX-0025 low pass filter is necessary for class-D amplifier measurement with AP analyzer.
  2. Two 22 $\mu$ H inductors are used in series with load resistor to emulate the small speaker for efficiency measurement.

### MUTE Operation

The MUTE pin is an input for controlling the output state of the PAM8006A. A logic high on this pin disables the outputs and low enables the outputs. This pin may be used as a quick disable or enable of the outputs without a volume fade.

### Shutdown Operation

The PAM8006A employs a shutdown operation mode to reduce supply current to the absolute minimum level during periods of non-use to save power. The  $\overline{SD}$  input terminal should be held high during normal operation when the amplifier is in use. Pulling  $\overline{SD}$  low causes the outputs to mute and the amplifier to enter a low-current state.  $\overline{SD}$  should never be left unconnected to prevent the amplifier from unpredictable operation.

For the best power-off pop performance, the amplifier should be set in shutdown mode prior to removing the power supply voltage.

### Internal 2.5V Bias Generator Capacitor Selection

The internal 2.5V bias generator (V2P5) provides the internal bias for the preamplifier stage. The external input capacitors and this internal reference allow the inputs to be biased within the optimal common-mode range of the input preamplifiers.

The selection of the capacitor value on the V2P5 terminal is critical for achieving the best device performance. During startup or recovery from shutdown state, the V2P5 capacitor determines the rate at which the amplifier starts up. When the voltage on the V2P5 capacitor equals 0.75 x V2P5, or 75% of its final value, the device turns on and the Class-D outputs start switching. The startup time is not critical for the best de-pop performance since any heard pop sound is the result of the Class-D output switching-on other than that of the startup time. However, at least a 0.47 $\mu$ F capacitor is recommended for the V2P5 capacitor.

Another function of the V2P5 capacitor is to filter high frequency noise on the internal 2.5V bias generator.

### Power Supply Decoupling, C<sub>s</sub>

The PAM8006A is a high-performance CMOS audio amplifier that requires adequate power supply decoupling to ensure the output total harmonic distortion (THD) as low as possible. Power supply decoupling also prevents oscillations caused by long lead between the amplifier and the speaker. The optimum decoupling is achieved by using two capacitors of different types that target different types of noise on the power supply leads. For higher frequency transients, spikes, or digital hash on the line, a good low equivalent-series resistance (ESR) ceramic capacitor, typically 1 $\mu$ F, is recommended, placing as close as possible to the device's VCC lead. To filter lower frequency noises, a large aluminum electrolytic capacitor of 10 $\mu$ F or greater is recommended, placing near the audio power amplifier. The 10 $\mu$ F capacitor also serves as a local storage capacitor for supplying current during large signal transients on the amplifier outputs.

### BSN and BSP Capacitors

The full H-bridge output stages use NMOS transistors only. They therefore require bootstrap capacitors for the high side of each output to turn on correctly. An at least 220nF ceramic capacitor, rated for at least 25V, must be connected from each output to its corresponding bootstrap input. Specifically, one 220nF capacitor must be connected from xOUTP to xBSP, and another 220nF capacitor from xOUTN to xBSN. It is recommended to use 1 $\mu$ F BST capacitor to replace 220nF or lower than 100Hz applications.



---

## Application Information (cont.)

---

### VCLAMP Capacitors

To ensure that the maximum gate-to-source voltage for the NMOS output transistors not exceeded, an internal regulators are used to clamp the gate voltage. A 1 $\mu$ F capacitors must be connected from VCLAMP to ground and must be rated for at least 25V. The voltages at the VCLAMP terminals vary with  $V_{CC}$  and may not be used to power any other circuitry.

### Internal Regulated 5-V Supply (AVDD)

The AVDD terminal is the output of an internally generated 5V supply, used for the oscillator, amplifier, power limit circuitry and logic control circuitry. It requires a 0.1 $\mu$ F to 1 $\mu$ F capacitor, placed very close to the pin to ground to keep the regulator stable. The regulator may not be used to power any external circuitry.

### Differential Input Power Limit

The differential input stage of the amplifier eliminates noises that appear on the two input lines of the channel. To use the PAM8006A with a differential source, connect the positive lead of the audio source to the INP input and the negative lead from the audio source to the INN input. To use the PAM8006A with a single-ended source, AC ground the INP input through a capacitor equal in value to the input capacitor on INN and apply the audio source to the INN input. In a single-ended input application, the INP input should be AC grounded at the audio source other than at the device input for best noise performance.

### Using Low-ESR Capacitors

Low-ESR capacitors are recommended throughout this application section. A real (with respect to ideal) capacitor can be modeled simply as a resistor in series with an ideal capacitor. The voltage drop across this resistor minimizes the beneficial effects of the capacitor in the circuit. The lower the equivalent value of this resistance the more the real capacitor behaves as an ideal capacitor.

### Short-Circuit Protection

The PAM8006A has short circuit protection circuitry on the outputs to prevent damage to the device when output-to-output shorts, output-to-GND shorts, or output-to-VCC shorts occur. Once a short-circuit is detected on the outputs, the output drive is immediately disabled. This is a latched fault and must be reset by cycling the voltage on the  $\overline{SD}$  pin to a logic low and back to the logic high state for normal operation. This will clear the short-circuit flag and allow for normal operation if the short was removed. If the short was not removed, the protection circuitry will again activate.

### Thermal Protection

Thermal protection on the PAM8006A prevents damage to the device when the internal die temperature exceeds 160°C. There is a  $\pm 15$  degree tolerance on this trip point from device to device. Once the die temperature exceeds the set thermal point, the device enters into the shutdown state and the outputs are disabled. This is not a latched fault. The thermal fault is cleared once the temperature of the die is reduced by 50°C. The device begins normal operation at this point without external system intervention.

### Power Limit

The voltage at PL pin can used to limit the power to levels below that which is possible based on the supply rail. Add a resistor from PL to ground to set the voltage at the PLIMIT pin. An external reference may also be used if tighter tolerance is required. Also add a 1 $\mu$ F capacitor from PL pin to ground. The PLIMIT circuit sets a limit on the output peak-to-peak voltage. The gain of Class-D amplifier will automatic reduced if the output power higher than setting value to make output power less than limited value and also provide good sound quality.

## Application Information (cont.)

### Power Limit (cont.)

The output power vs PL pin resistor value as below.

$$V_{CC} = 12V, R_{LOAD} = 8\Omega$$

R(Ω)	PL(V)	PL(W)	R(Ω)	PL(V)	PL(W)
56K	0.61	3.1	100K	0.99	8.1
62K	0.67	3.7	110K	1.07	9.0
68K	0.73	4.3	120K	1.15	9.6
75K	0.79	5.1	130K	1.22	10.0
82K	0.85	6.0	140K	1.36	10.7
91K	0.92	7.0	—	—	—

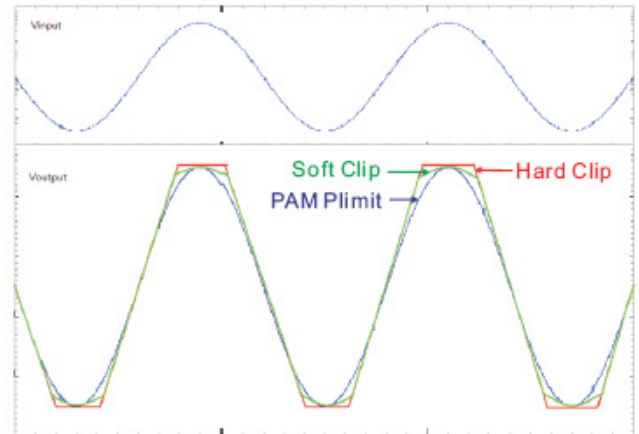

### Power Up/Down Sequence

The PAM8006A employs a shutdown operation mode to reduce supply current to the absolute minimum level during periods of non-use to save power. The SD input terminal should be held high during normal operation when the amplifier is in use. Pulling SD low causes the outputs to mute and the amplifier to enter a low-current state. SD should never be left unconnected to prevent the amplifier from unpredictable operation. Suggest PL starting voltage is greater than 5V.

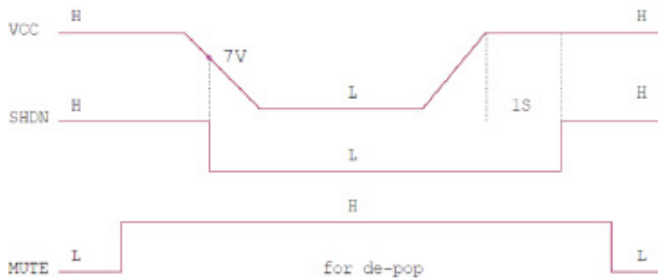

Start-up /power down sequencer recommended.

**Ordering Information**

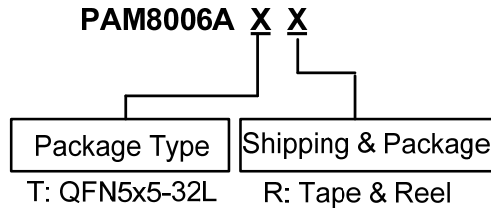

Part Number	Part Marking	Package Type	Standard Package
PAM8006ATR	PAM8006A XXXYWWLL	QFN5x5-32L	3000 Units/Tape&Reel

**Marking Information**

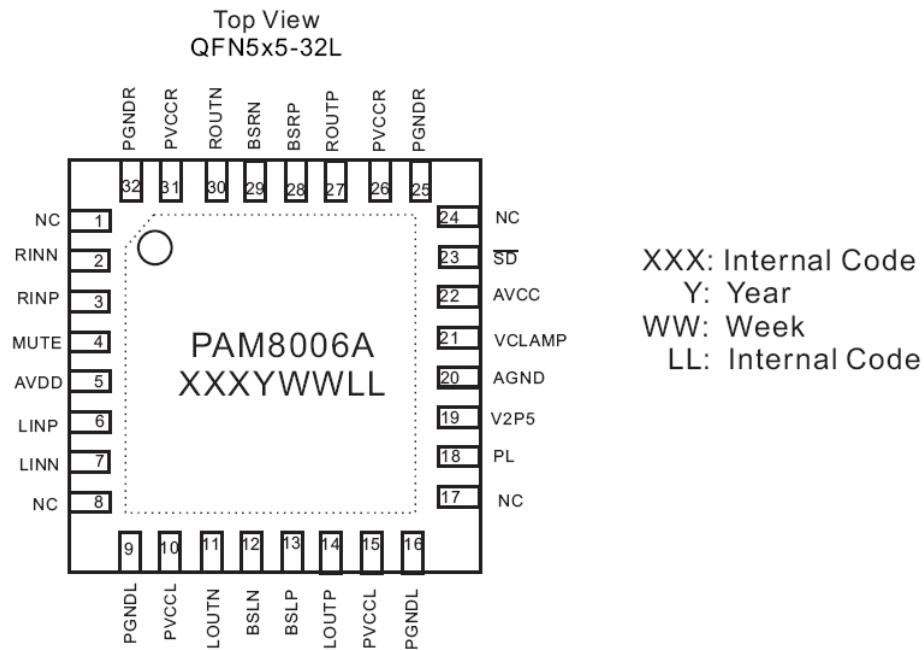

**Package Outline Dimensions** (All dimensions in mm.)

QFN5x5-32L

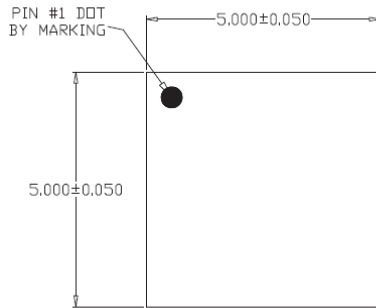

TOP VIEW

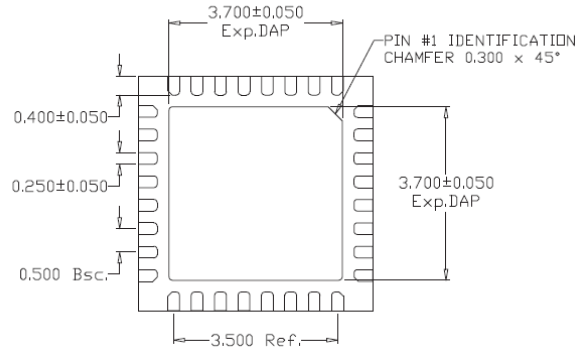

BOTTOM VIEW

A	MAX.	0.800
	NOM.	0.750
	MIN.	0.700

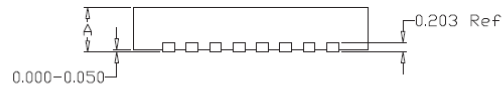

SIDE VIEW

#### IMPORTANT NOTICE

DIODES INCORPORATED MAKES NO WARRANTY OF ANY KIND, EXPRESS OR IMPLIED, WITH REGARDS TO THIS DOCUMENT, INCLUDING, BUT NOT LIMITED TO, THE IMPLIED WARRANTIES OF MERCHANTABILITY AND FITNESS FOR A PARTICULAR PURPOSE (AND THEIR EQUIVALENTS UNDER THE LAWS OF ANY JURISDICTION).

Diodes Incorporated and its subsidiaries reserve the right to make modifications, enhancements, improvements, corrections or other changes without further notice to this document and any product described herein. Diodes Incorporated does not assume any liability arising out of the application or use of this document or any product described herein; neither does Diodes Incorporated convey any license under its patent or trademark rights, nor the rights of others. Any Customer or user of this document or products described herein in such applications shall assume all risks of such use and will agree to hold Diodes Incorporated and all the companies whose products are represented on Diodes Incorporated website, harmless against all damages.

Diodes Incorporated does not warrant or accept any liability whatsoever in respect of any products purchased through unauthorized sales channel. Should Customers purchase or use Diodes Incorporated products for any unintended or unauthorized application, Customers shall indemnify and hold Diodes Incorporated and its representatives harmless against all claims, damages, expenses, and attorney fees arising out of, directly or indirectly, any claim of personal injury or death associated with such unintended or unauthorized application.

Products described herein may be covered by one or more United States, international or foreign patents pending. Product names and markings noted herein may also be covered by one or more United States, international or foreign trademarks.

This document is written in English but may be translated into multiple languages for reference. Only the English version of this document is the final and determinative format released by Diodes Incorporated.

#### LIFE SUPPORT

Diodes Incorporated products are specifically not authorized for use as critical components in life support devices or systems without the express written approval of the Chief Executive Officer of Diodes Incorporated. As used herein:

A. Life support devices or systems are devices or systems which:

1. are intended to implant into the body, or
2. support or sustain life and whose failure to perform when properly used in accordance with instructions for use provided in the labeling can be reasonably expected to result in significant injury to the user.

B. A critical component is any component in a life support device or system whose failure to perform can be reasonably expected to cause the failure of the life support device or to affect its safety or effectiveness.

Customers represent that they have all necessary expertise in the safety and regulatory ramifications of their life support devices or systems, and acknowledge and agree that they are solely responsible for all legal, regulatory and safety-related requirements concerning their products and any use of Diodes Incorporated products in such safety-critical, life support devices or systems, notwithstanding any devices- or systems-related information or support that may be provided by Diodes Incorporated. Further, Customers must fully indemnify Diodes Incorporated and its representatives against any damages arising out of the use of Diodes Incorporated products in such safety-critical, life support devices or systems.

Copyright © 2013, Diodes Incorporated

[www.diodes.com](http://www.diodes.com)