

## Compact, Low Power Consumption, Triple SPDT (Triple 2:1 Multiplexers)

### DESCRIPTION

The DG9454 is a triple SPDT (triple 2:1 multiplexers) with enhanced performance on low power consumption, while guarantees 1.8 V logic compatible over the full operation voltage range.

The DG9454 is designed to operate from a + 2.7 V to + 13.2 V supply at  $V_{+}$ , and + 2.5 V to + 5.5 V at  $V_{L}$ .

The DG9454 is a high precision switch of low parasitic capacitance, low leakage, low charge injection, and fast switching speed.

Processed with advanced CMOS technology, the DG9454 conducts equally well in both directions, offers rail to rail analog signal handling and can be used both as multiplexers as well as de-multiplexers.

The advantages of DG9454 at size, weight, power consumption, and low voltage control capability make it ideal for portable consumer applications such as 3D glasses (3D goggles). Its precise switching, wide dynamic range, and low parasitic characters make it a high performance switch for healthcare, data acquisition, and instrument products.

The DG9454 operating temperature is specified from - 40 °C to + 85 °C and are available and the ultra compact 1.8 mm x 2.6 mm miniQFN16 packages.

As a comitted partner to the community and the environment, Vishay Siliconix manufactures this product with lead (Pb)-free device terminations. DG9454 is offered in a miniQFN package. The miniQFN package has a nickel-palladium-gold device termination and is represented by the lead (Pb)-free “-E4” suffix. The nickel-palladium-gold device terminations meet all JEDEC standards for reflow and MSL ratings.

### FEATURES

- Operates with  $V_{+} = 2.7\text{ V to }13.2\text{ V}$ ;  
 $V_{L} = 2.5\text{ V to }5.5\text{ V}$
- Guaranteed 1.8 V logic control at full  $V_{+}$  range
- Low power consumption, < 1  $\mu\text{A}$
- High bandwidth: 540 MHz
- Low charge injection over the full signal range (less than 0.9 pQ)
- Low switch capacitance ( $C_{S(\text{off})}$  2 pF typ.)
- Good isolation and crosstalk performance (typ. - 65 dB at 10 MHz)
- Compact and light miniQFN16 package (1.8 mm x 2.6 mm)
- **Compliant to RoHS Directive 2002/95/EC**
- **Halogen-free according to IEC 61249-2-21 definition**



**RoHS**  
COMPLIANT  
HALOGEN  
**FREE**

### APPLICATIONS

- 3D glasses (goggles)
- Touch panels
- Data acquisition
- Medical and healthcare devices
- Control and automation equipments
- Test instruments

### FUNCTIONAL BLOCK DIAGRAM AND PIN CONFIGURATION

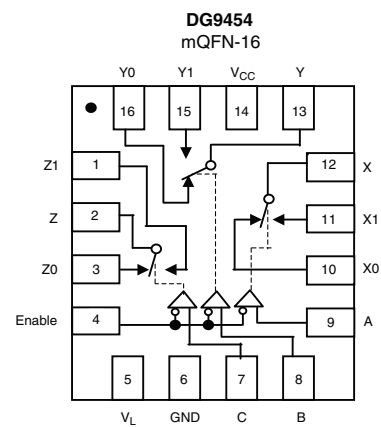

Top View

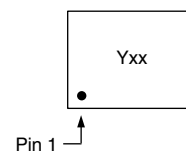

Device Marking: 5xx for DG9454  
(miniQFN16)

xx = Date/Lot Traceability Code



TRUTH TABLE				
Enable Input	Select Inputs			On Switches
	C	B	A	DG9454
H	X	X	X	All Switches Open
L	L	L	L	X to X0, Y to Y0, Z to Z0
L	L	L	H	X to X1, Y to Y0, Z to Z0
L	L	H	L	X to X0, Y to Y1, Z to Z0
L	L	H	H	X to X1, Y to Y1, Z to Z0
L	H	L	L	X to X0, Y to Y0, Z to Z1
L	H	L	H	X to X1, Y to Y0, Z to Z1
L	H	H	L	X to X0, Y to Y1, Z to Z1
L	H	H	H	X to X1, Y to Y1, Z to Z1

ORDERING INFORMATION		
Temp. Range	Package	Part Number
DG9454		
- 40 °C to 125 °C <sup>a</sup>	16-Pin miniQFN	DG9454EN-T1-E4

Notes:

a. - 40 °C to 85 °C datasheet limits apply.

ABSOLUTE MAXIMUM RATINGS (T <sub>A</sub> = 25 °C, unless otherwise noted)			
Parameter		Limit	Unit
Digital Inputs <sup>a</sup> , V <sub>S</sub> , V <sub>D</sub> , V <sub>L</sub>		GND - 0.3 to (V <sub>+</sub> ) + 0.3 or 30 mA, whichever occurs first	V
V <sub>+</sub> to GND		14	
Continuous Current (Any terminal)		30	mA
Peak Current, S or D (Pulsed 1 ms, 10 % duty cycle)		100	
Storage Temperature		- 65 to 150	°C
Power Dissipation <sup>b</sup>	16-Pin miniQFN <sup>c, d</sup>	525	mW
Thermal Resistance <sup>b</sup>	16-Pin miniQFN <sup>d</sup>	152	°C/W
Latch-up (per JEDEC78)			mA

Notes:

a. Signals on SX, DX, V<sub>L</sub> or INX exceeding V<sub>+</sub> will be clamped by internal diodes. Limit forward diode current to maximum current ratings.

b. All leads welded or soldered to PC board.

c. Derate 6.6 mW/°C above 70 °C.

d. Manual soldering with iron is not recommended for leadless components. The miniQFN-16 is a leadless package. The end of the lead terminal is exposed copper (not plated) as a result of the singulation process in manufacturing. A solder fillet at the exposed copper lip cannot be guaranteed and is not required to ensure adequate bottom side solder interconnection.

SPECIFICATIONS FOR UNIPOLAR SUPPLIES									
Parameter	Symbol	Test Conditions Unless Otherwise Specified V <sub>CC</sub> = + 12 V, V <sub>L</sub> = 2.7 V V <sub>IN(A, B, C and enable)</sub> = 1.6 V, 0.5 V <sup>a</sup>	Temp. <sup>b</sup>	Typ. <sup>c</sup>	- 40 °C to + 125 °C		- 40 °C to + 85 °C		Unit
					Min. <sup>d</sup>	Max. <sup>d</sup>	Min. <sup>d</sup>	Max. <sup>d</sup>	
<b>Analog Switch</b>									
Analog Signal Range <sup>e</sup>	V <sub>ANALOG</sub>		Full		0	12	0	12	V
On-Resistance	R <sub>DS(on)</sub>	I <sub>S</sub> = 1 mA, V <sub>D</sub> = 0.7 V, 6.0 V, 11.3 V	Room Full	80		120		120	Ω
On-Resistance Match	ΔR <sub>ON</sub>	I <sub>S</sub> = 1 mA, V <sub>D</sub> = + 0.7 V	Room Full	4		7		7	
On-Resistance Flatness	R <sub>FLATNESS</sub>	I <sub>S</sub> = 1 mA, V <sub>D</sub> = 0.7 V, 6.0 V, 11.3 V	Room Full	32		26		26	
						30		28	

<b>SPECIFICATIONS FOR UNIPOLAR SUPPLIES</b>									
Parameter	Symbol	Test Conditions Unless Otherwise Specified $V_{CC} = +12\text{ V}$ , $V_L = 2.7\text{ V}$ $V_{IN(A, B, C \text{ and enable})} = 1.6\text{ V}$ , $0.5\text{ V}^a$	Temp. <sup>b</sup>	Typ. <sup>c</sup>	- 40 °C to + 125 °C		- 40 °C to + 85 °C		Unit
					Min. <sup>d</sup>	Max. <sup>d</sup>	Min. <sup>d</sup>	Max. <sup>d</sup>	
<b>Analog Switch</b>									
Switch Off Leakage Current	$I_{S(off)}$	$V_+ = +13.2\text{ V}$ , $V_L = 2.7\text{ V}$ $V_D = 1\text{ V}/12.2\text{ V}$ , $V_S = 12.2\text{ V}/1\text{ V}$	Room Full	$\pm 0.02$	- 1	1	- 1	1	nA
	$I_{D(off)}$		Room Full	$\pm 0.02$	- 1	1	- 1	1	
Channel On Leakage Current	$I_{D(on)}$	$V_+ = +13.2\text{ V}$ , $V_L = 2.7\text{ V}$ $V_D = V_S = 1\text{ V}/12.2\text{ V}$	Room Full	$\pm 0.02$	- 1	1	- 1	1	
<b>Digital Control</b>									
Logic Low Input Voltage	$V_{INL}$	$V_L = 2.7\text{ V}$	Full			0.5		0.5	V
Logic High Input Voltage	$V_{INH}$		Full		1.6		1.6		
Logic Low Input Current	$I_L$	$V_{IN} A0, A1, A2$ and enable under test = 0.5 V	Full	0.01	- 1	1	- 1	1	$\mu\text{A}$
Logic High Input current	$I_H$	$V_{IN} A0, A1, A2$ and enable above test = 1.6 V	Full	0.01	- 1	1	- 1	1	
<b>Dynamic Characteristics</b>									
Transition Time	$t_{TRANS}$	$R_L = 300\ \Omega$ , $C_L = 35\text{ pF}$ see figure 1, 2, 3	Room Full	80		135		135	ns
Enable Turn-On Time	$t_{ON(EN)}$		Room Full	115		180		180	
Enable Turn-Off Time	$t_{OFF(EN)}$		Room Full	46		110		110	
Break-Before-Make Time Delay	$t_D$		Room Full	37	12		12		
Charge Injection <sup>e</sup>	Q	$C_L = 1\text{ nF}$ , $R_{GEN} = 0\ \Omega$ , $V_{GEN} = 0\text{ V}$	Full	0.86					pC
Off Isolation <sup>e</sup>	OIRR	$f = 1\text{ MHz}$ , $R_L = 50\ \Omega$ , $C_L = 5\text{ pF}$	100 kHz	Room	< - 90				dB
			1 MHz	Room	- 80				
Crosstalk <sup>e</sup>	$X_{TALK}$		10 MHz	Room	- 61				
			100 kHz	Room	< - 90				
			1 MHz	Room	- 81				
			10 MHz	Room	- 65				
Bandwidth, - 3dB <sup>e</sup>	BW	$R_L = 50\ \Omega$	Room	540				MHz	
Source Off Capacitance <sup>e</sup>	$C_{S(off)}$	$f = 1\text{ MHz}$	Room	2				pF	
Drain Off Capacitance <sup>e</sup>	$C_{D(off)}$		Room	3					
Channel On Capacitance <sup>e</sup>	$C_{D(on)}$		Room	6					
Total Harmonic Distortion <sup>e</sup>	THD	Signal = 1 $V_{RMS}$ , 20 Hz to 20 kHz, $R_L = 600\ \Omega$	Room	0.01				%	
<b>Power Supply</b>									
Power Supply Range	$I_+$	$V_{IN(A, B, C \text{ and enable})} = 0\text{ V}$ or + 12 V	Room Full	0.05		1		1	$\mu\text{A}$
Ground Current	$I_{GND}$		Room Full	0.05	- 1		- 1		
Logic Supply Current	$I_L$	$V_L = 2.7\text{ V}$	Room Full	0.05		1		1	

Notes:

- $V_{IN}$  = input voltage to perform proper function.
- Room - 25 °C, Full = as determined by the operating temperature suffix.
- Typical values are for DESIGN AID ONLY, not guaranteed nor subject to production testing.
- The algebraic convention whereby the most negative value is a minimum and the most positive a maximum, is used in this data sheet.
- Guaranteed by design, not subject to production test.

SPECIFICATIONS FOR UNIPOLAR SUPPLIES									
Parameter	Symbol	Test Conditions Unless Otherwise Specified $V_{CC} = +5\text{ V}$ , $V_L = 2.7\text{ V}$ $V_{IN(A, B, C \text{ and enable})} = 1.5\text{ V}$ , $0.6\text{ V}^a$	Temp. <sup>b</sup>	Typ. <sup>c</sup>	-40 °C to +125 °C		-40 °C to +85 °C		Unit
					Min. <sup>d</sup>	Max. <sup>d</sup>	Min. <sup>d</sup>	Max. <sup>d</sup>	
<b>Analog Switch</b>									
Analog Signal Range <sup>e</sup>	$V_{ANALOG}$		Full		0	5	0	5	V
On-Resistance	$R_{ON}$	$I_S = 1\text{ mA}$ , $V_D = 0\text{ V}$ , $+3.5\text{ V}$	Room Full	105		165 205		165 194	$\Omega$
On-Resistance Match	$\Delta R_{ON}$	$I_S = 1\text{ mA}$ , $V_D = +3.5\text{ V}$	Room Full	3.2		8 13		8 10	
On-Resistance Flatness	$R_{FLATNESS}$	$I_S = 1\text{ mA}$ , $V_D = 0\text{ V}$ , $+3\text{ V}$	Room Full	17		26 30		26 28	
Switch Off Leakage Current	$I_{S(off)}$	$V_+ = +5.5\text{ V}$ , $V_- = 0\text{ V}$ $V_D = 1\text{ V}/4.5\text{ V}$ , $V_S = 4.5\text{ V}/1\text{ V}$	Room Full	$\pm 0.02$	-1 -50	1 50	-1 -5	1 5	nA
	$I_{D(off)}$		Room Full	$\pm 0.02$	-1 -50	1 50	-1 -5	1 5	
Channel On Leakage Current	$I_{D(on)}$	$V_+ = +5.5\text{ V}$ , $V_- = 0\text{ V}$ $V_D = V_S = 1\text{ V}/4.5\text{ V}$	Room Full	$\pm 0.02$	-1 -50	1 50	-1 -5	1 5	
<b>Digital Control</b>									
$V_{IN(A, B, C \text{ and enable})}$ Low	$V_{IL}$	$V_L = 2.7\text{ V}$	Full			0.6		0.6	V
$V_{IN(A, B, C \text{ and enable})}$ High	$V_{IH}$	$V_L = 2.7\text{ V}$	Full		1.5		1.5		
Input Current, $V_{IN}$ Low	$I_L$	$V_{IN(A, B, C \text{ and enable})}$ under test = $0.6\text{ V}$	Full	0.01	-1	1	-1	1	$\mu\text{A}$
Input Current, $V_{IN}$ High	$I_H$	$V_{IN(A, B, C \text{ and enable})}$ under test = $1.5\text{ V}$	Full	0.01	-1	1	-1	1	
<b>Dynamic Characteristics</b>									
Transition Time	$t_{TRANS}$	$R_L = 300\ \Omega$ , $C_L = 35\text{ pF}$ see figure 1, 2, 3	Room Full	96		175 250		175 210	ns
Enable Turn-On Time	$t_{ON}$		Room Full	200		295 365		295 330	
Enable Turn-Off Time	$t_{OFF}$		Room Full	60		155 225		155 190	
Break-Before-Make Time Delay	$t_D$		Room Full	50	20		20		
Charge Injection <sup>e</sup>	Q	$V_g = 0\text{ V}$ , $R_g = 0\ \Omega$ , $C_L = 1\text{ nF}$	Full	0.4					pC
Off Isolation <sup>e</sup>	OIRR	$R_L = 50\ \Omega$ , $C_L = 5\text{ pF}$ $f = 100\text{ kHz}$	Room	< -90					dB
Channel-to-Channel Crosstalk <sup>e</sup>	$X_{TALK}$		Room	< -90					
Source Off Capacitance <sup>e</sup>	$C_{S(off)}$	f = 1 MHz	Room	2					pF
Drain Off Capacitance <sup>e</sup>	$C_{D(off)}$		Room	4					
Channel On Capacitance <sup>e</sup>	$C_{D(on)}$		Room	7					
<b>Power Supply</b>									
Power Supply Current	$I_+$	$V_{IN(A, B, C \text{ and enable})} = 0\text{ V}$ or $5\text{ V}$	Room Full	0.05		1 10		1 10	$\mu\text{A}$
Ground Current	$I_{GND}$		Room Full	-0.05	-1 -10		-1 -10		
Logic Supply Current	$I_L$	$V_L = 2.7\text{ V}$	Room Full	0.05		1 10		1 10	

Notes:

- a.  $V_{IN}$  = input voltage to perform proper function.
- b. Room - 25 °C, Full = as determined by the operating temperature suffix.
- c. Typical values are for DESIGN AID ONLY, not guaranteed nor subject to production testing.
- d. The algebraic convention whereby the most negative value is a minimum and the most positive a maximum, is used in this data sheet.
- e. Guaranteed by design, not subject to production test.

<b>SPECIFICATIONS FOR UNIPOLAR SUPPLIES</b>									
Parameter	Symbol	Test Conditions Unless Otherwise Specified $V_{CC} = +3\text{ V}$ , $V_L = 2.7\text{ V}$ $V_{IN(A, B, C \text{ and enable})} = 1.5\text{ V}$ , $0.6\text{ V}^a$	Temp. <sup>b</sup>	Typ. <sup>c</sup>	-40 °C to +125 °C		-40 °C to +85 °C		Unit
					Min. <sup>d</sup>	Max. <sup>d</sup>	Min. <sup>d</sup>	Max. <sup>d</sup>	
<b>Analog Switch</b>									
Analog Signal Range <sup>e</sup>	$V_{ANALOG}$		Full		0	3	0	3	V
On-Resistance	$R_{DS(on)}$	$I_S = 1\text{ mA}$ , $V_D = 1.5\text{ V}$	Room Full	171		265 310		265 289	$\Omega$
Switch Off Leakage Current	$I_{S(off)}$	$V_+ = 3.3\text{ V}$ , $V_L = 2.7\text{ V}$ $V_D = 0.3\text{ V}/3.0\text{ V}$ , $V_S = 3.0\text{ V}/0.3\text{ V}$	Room Full	$\pm 0.02$	-1 -50	1 50	-1 -5	1 5	nA
	$I_{D(off)}$		Room Full	$\pm 0.02$	-1 -50	1 50	-1 -5	1 5	
Channel On Leakage Current	$I_{D(on)}$	$V_+ = 3.3\text{ V}$ , $V_L = 2.7\text{ V}$ $V_S = V_D = 0.3\text{ V}/3.0\text{ V}$	Room Full	$\pm 0.02$	-1 -50	1 50	-1 -5	1 5	
<b>Digital Control</b>									
Logic Low Input Voltage	$V_{INL}$	$V_L = +2.7\text{ V}$	Full			0.6		0.6	V
Logic High Input Voltage	$V_{INH}$		Full		1.5		1.5		
Logic Low Input Current	$I_L$	$V_{IN} A0, A1, A2$ and enable under test = $0.6\text{ V}$	Full	0.01	-1	1	-1	1	$\mu\text{A}$
Logic High Input Current	$I_H$	$V_{IN} A0, A1, A2$ and enable above test = $1.5\text{ V}$	Full	0.01	-1	1	-1	1	
<b>Dynamic Characteristics</b>									
Transition Time	$t_{TRANS}$	$R_L = 300\ \Omega$ , $C_L = 35\text{ pF}$ see figure 1, 2, 3	Room Full	151		270 355		270 315	ns
Enable Turn-On Time	$t_{ON(EN)}$		Room Full	390		510 610		510 565	
Enable Turn-Off Time	$t_{OFF(EN)}$		Room Full	90		220 320		220 275	
Break-Before-Make Time Delay	$t_D$		Room Full	90	35		35		
Charge Injection <sup>e</sup>	Q	$C_L = 1\text{ nF}$ , $R_{GEN} = 0\ \Omega$ , $V_{GEN} = 0\text{ V}$	Full	0.5					pC
Off Isolation <sup>e</sup>	OIRR	$f = 1\text{ MHz}$ , $R_L = 50\ \Omega$ , $C_L = 5\text{ pF}$	Room	< -90					dB
Crosstalk <sup>e</sup>	$X_{TALK}$		Room	< -90					
Source Off Capacitance <sup>e</sup>	$C_{S(off)}$	$f = 1\text{ MHz}$	Room	2					pF
Drain Off Capacitance <sup>e</sup>	$C_{D(off)}$		Room	4					
Channel On Capacitance <sup>e</sup>	$C_{D(on)}$		Room	7					
<b>Power Supply</b>									
Power Supply Range	$I_+$	$V_{IN(A, B, C \text{ and enable})} = 0\text{ V or } +3\text{ V}$	Room Full	0.05		1 10		1 10	$\mu\text{A}$
Ground Current	$I_{GND}$		Room Full	0.05	-1 -10		-1 -10		
Logic Supply Current	$I_L$	$V_L = 2.7\text{ V}$	Room Full	0.05		1 10		1 10	

Notes:

- $V_{IN}$  = input voltage to perform proper function.
- Room - 25 °C, Full = as determined by the operating temperature suffix.
- Typical values are for DESIGN AID ONLY, not guaranteed nor subject to production testing.
- The algebraic convention whereby the most negative value is a minimum and the most positive a maximum, is used in this data sheet.
- Guaranteed by design, not subject to production test.

*Stresses beyond those listed under "Absolute Maximum Ratings" may cause permanent damage to the device. These are stress ratings only, and functional operation of the device at these or any other conditions beyond those indicated in the operational sections of the specifications is not implied. Exposure to absolute maximum rating conditions for extended periods may affect device reliability.*

**TYPICAL CHARACTERISTICS** (25 °C, unless otherwise noted)

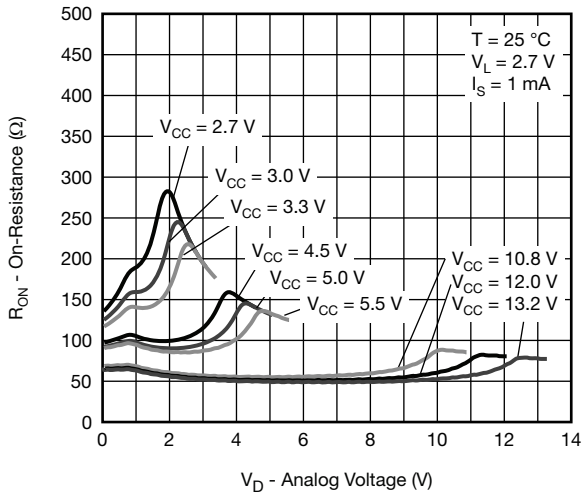

**On-Resistance vs.  $V_D$  and Signal Supply Voltage**

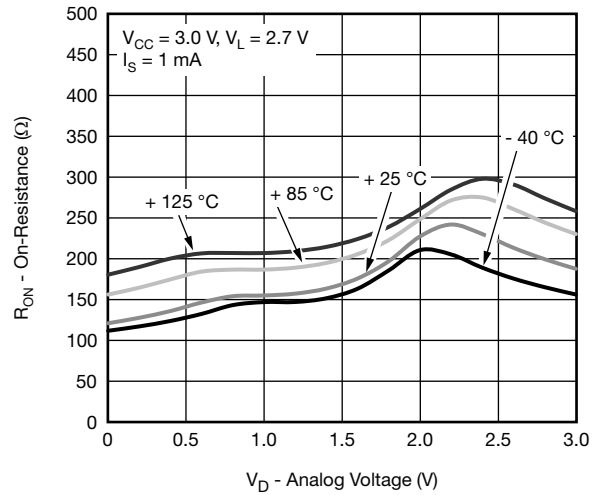

**On-Resistance vs. Analog Voltage and Temperature**

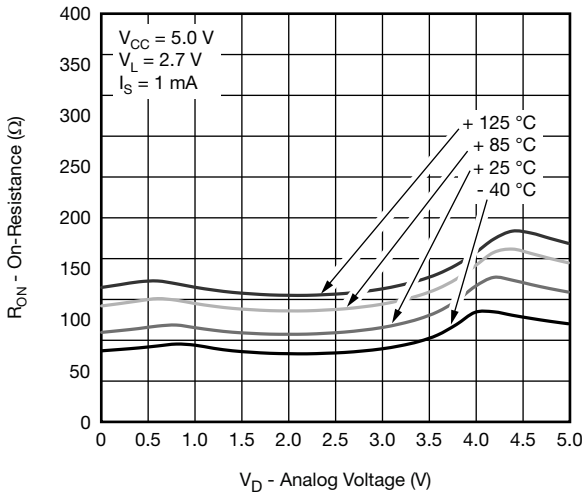

**On-Resistance vs. Analog Voltage and Temperature**

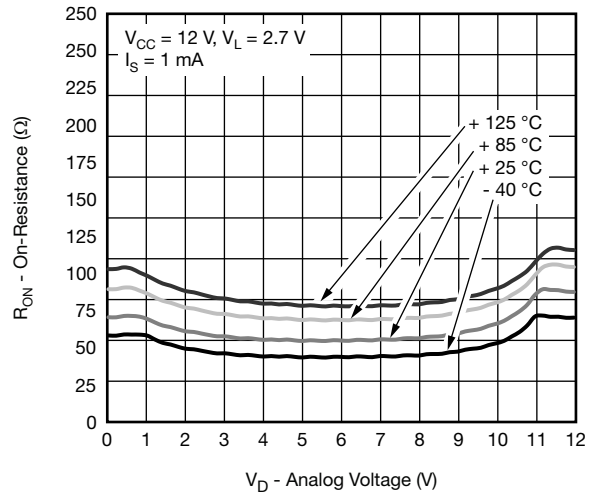

**On-Resistance vs. Analog Voltage and Temperature**

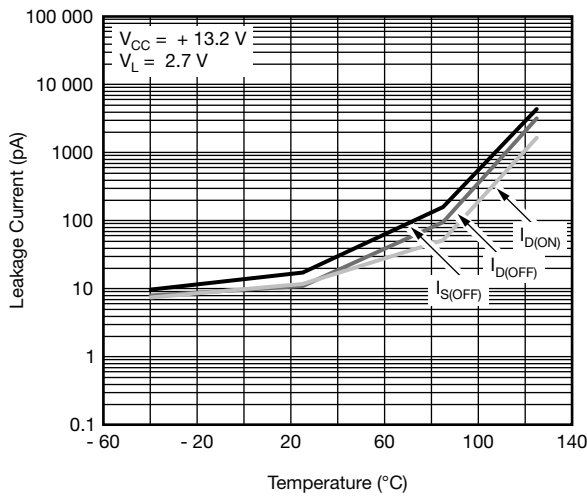

**Leakage Current vs. Temperature**

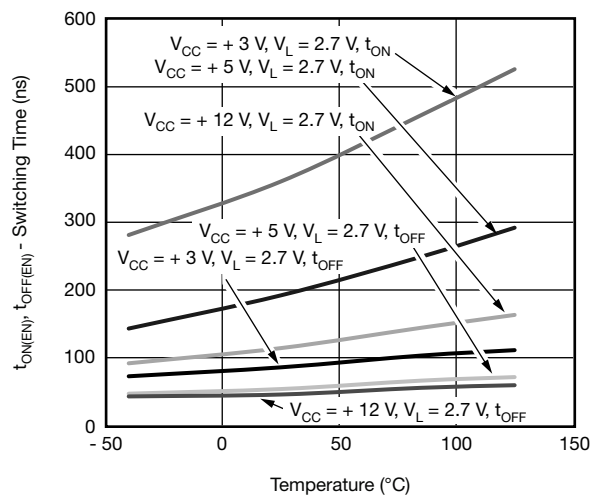

**Switching Time vs. Temperature**

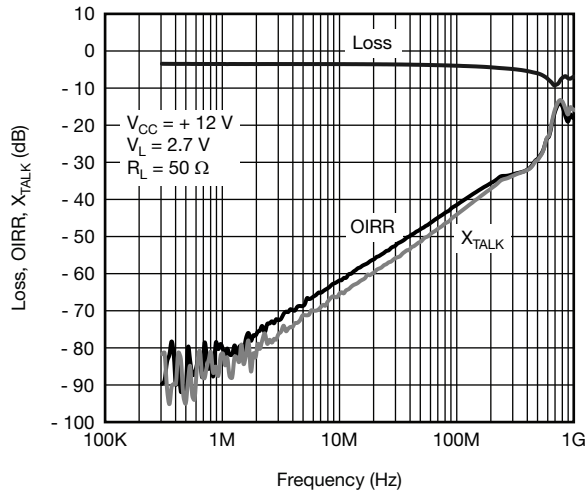
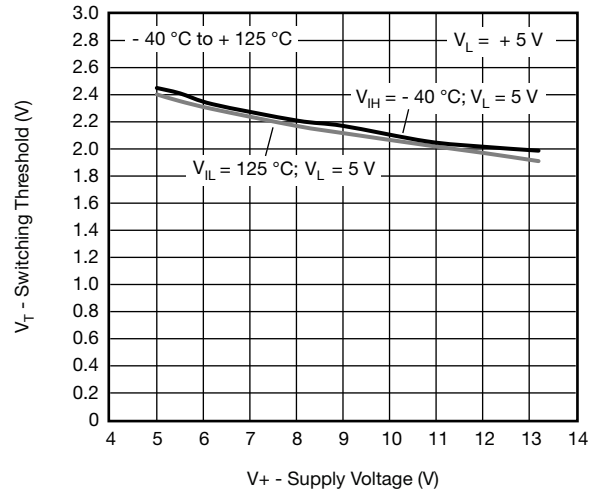
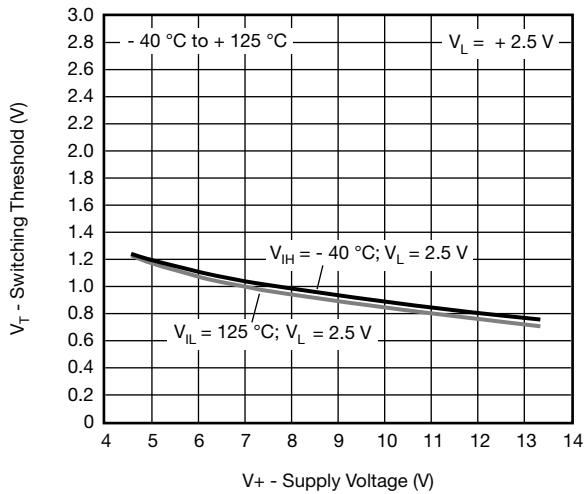
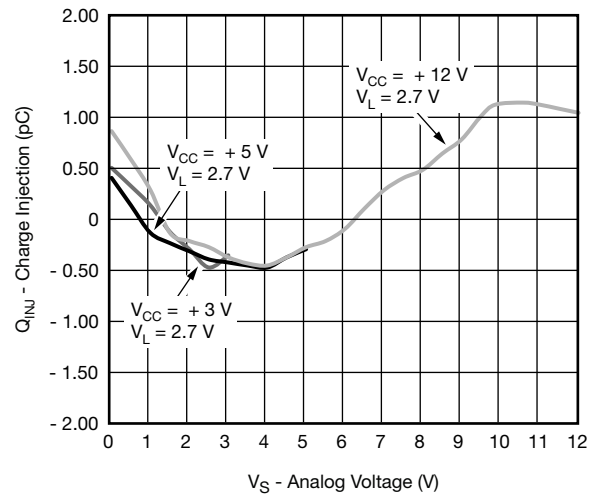
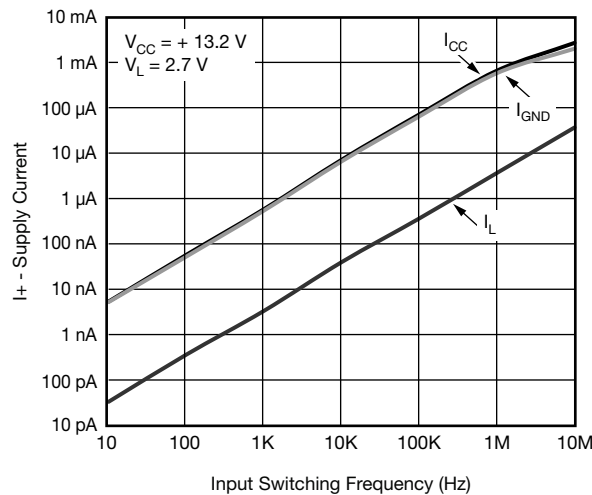
**TYPICAL CHARACTERISTICS** (25 °C, unless otherwise noted)

**Insertion Loss, Off-Isolation, Crosstalk vs. Frequency**

**Switching Threshold vs. Logic Supply Voltage**

**Switching Threshold vs. Logic Supply Voltage**

**Charge Injection vs. Analog Voltage**

**Current vs. Frequency**

TEST CIRCUITS

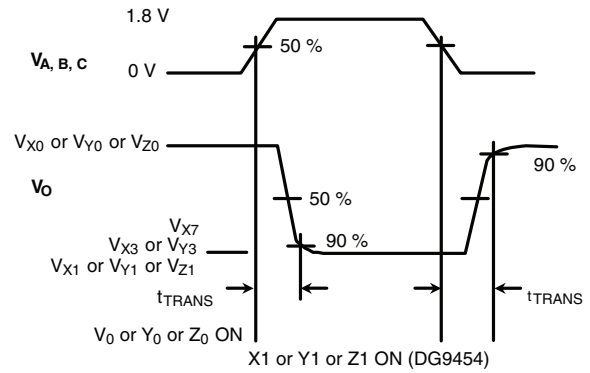
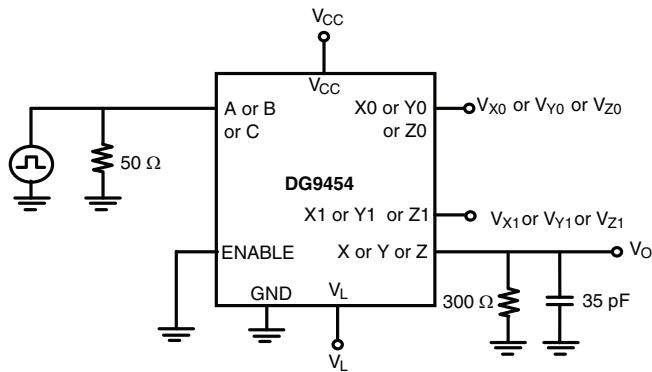

Figure 1. Transition Time

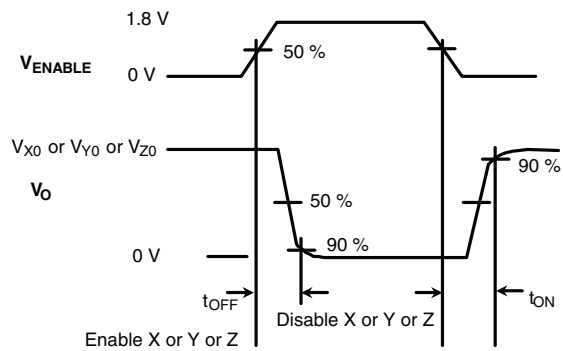
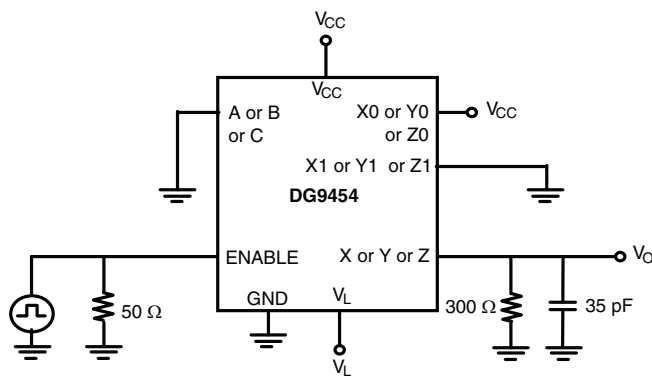

Figure 2. Enable Switching Time

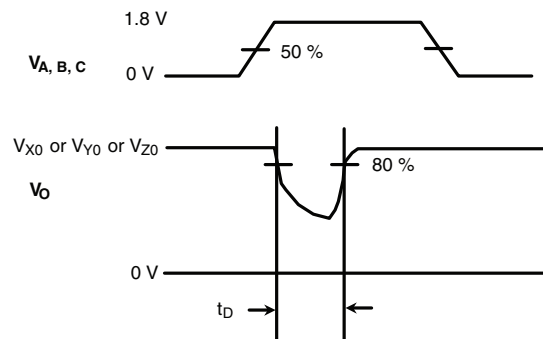
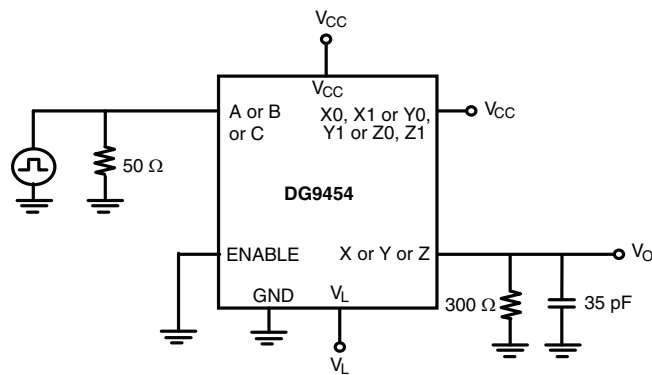
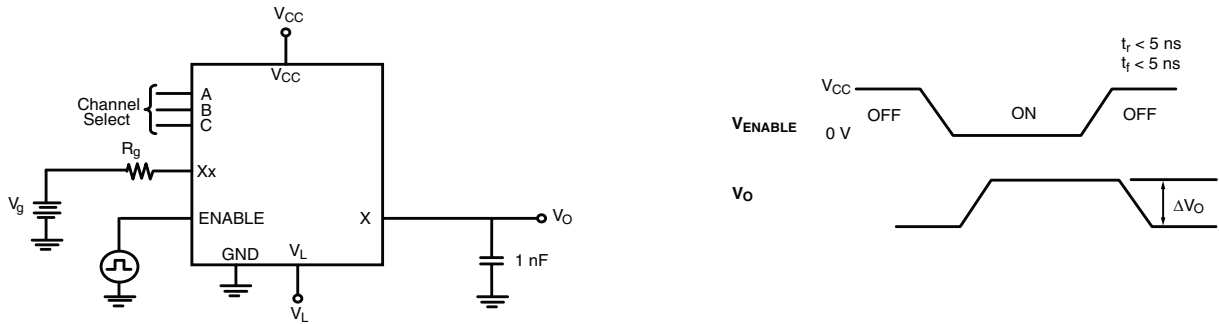
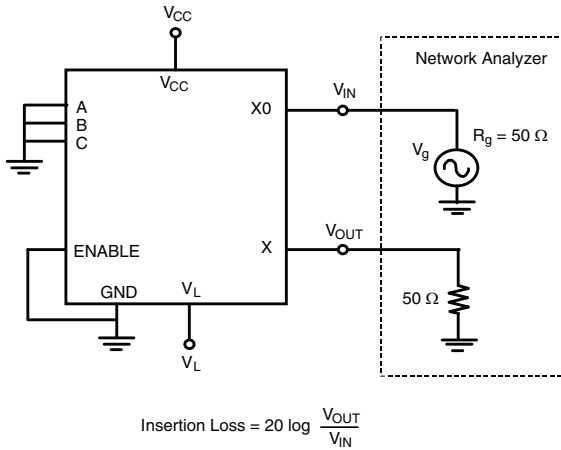
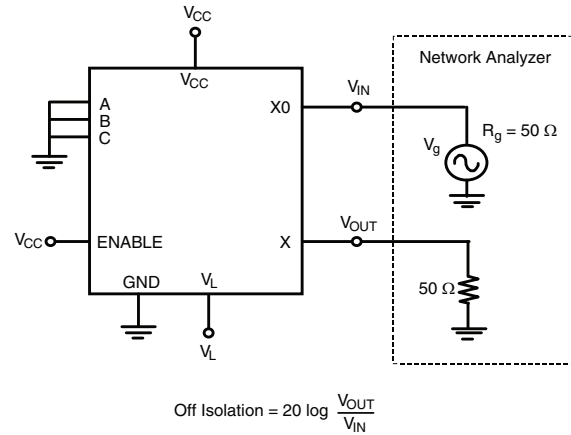
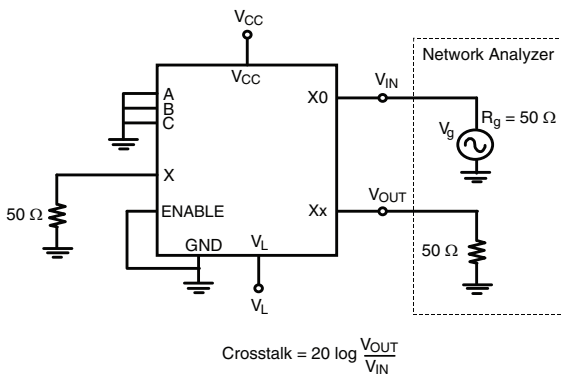
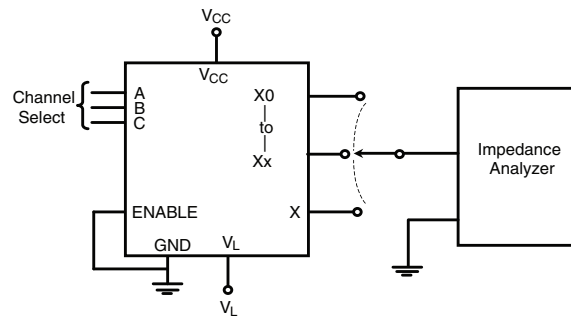
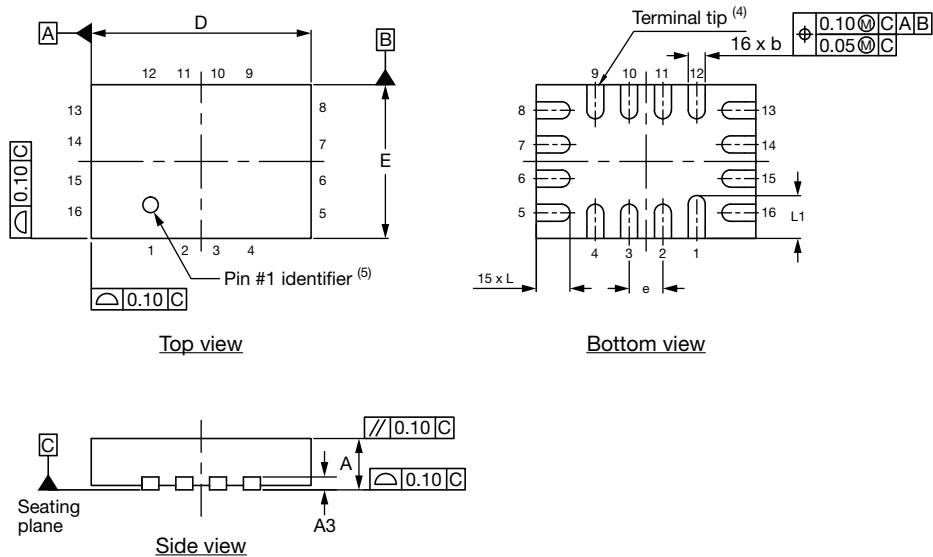

Figure 3. Break-Before-Make

**TEST CIRCUITS**

**Figure 4. Charge Injection**

**Figure 5. Insertion Loss**

**Figure 6. Off Isolation**

**Figure 7. Crosstalk**

**Figure 8. Source, Drain Capacitance**

Vishay Siliconix maintains worldwide manufacturing capability. Products may be manufactured at one of several qualified locations. Reliability data for Silicon Technology and Package Reliability represent a composite of all qualified locations. For related documents such as package/tape drawings, part marking, and reliability data, see [www.vishay.com/ppg?67185](http://www.vishay.com/ppg?67185).

## Thin miniQFN16 Case Outline



DIMENSIONS	MILLIMETERS <sup>(1)</sup>			INCHES		
	MIN.	NOM.	MAX.	MIN.	NOM.	MAX.
A	0.50	0.55	0.60	0.020	0.022	0.024
A1	0	-	0.05	0	-	0.002
A3	0.15 ref.			0.006 ref.		
b	0.15	0.20	0.25	0.006	0.008	0.010
D	2.50	2.60	2.70	0.098	0.102	0.106
e	0.40 BSC			0.016 BSC		
E	1.70	1.80	1.90	0.067	0.071	0.075
L	0.35	0.40	0.45	0.014	0.016	0.018
L1	0.45	0.50	0.55	0.018	0.020	0.022
N <sup>(3)</sup>	16			16		
Nd <sup>(3)</sup>	4			4		
Ne <sup>(3)</sup>	4			4		

### Notes

- (1) Use millimeters as the primary measurement.
- (2) Dimensioning and tolerances conform to ASME Y14.5M. - 1994.
- (3) N is the number of terminals. Nd and Ne is the number of terminals in each D and E site respectively.
- (4) Dimensions b applies to plated terminal and is measured between 0.15 mm and 0.30 mm from terminal tip.
- (5) The pin 1 identifier must be existed on the top surface of the package by using identification mark or other feature of package body.
- (6) Package warpage max. 0.05 mm.

ECN: T16-0226-Rev. B, 09-May-16  
DWG: 6023

**RECOMMENDED MINIMUM PADS FOR MINI QFN 16L**

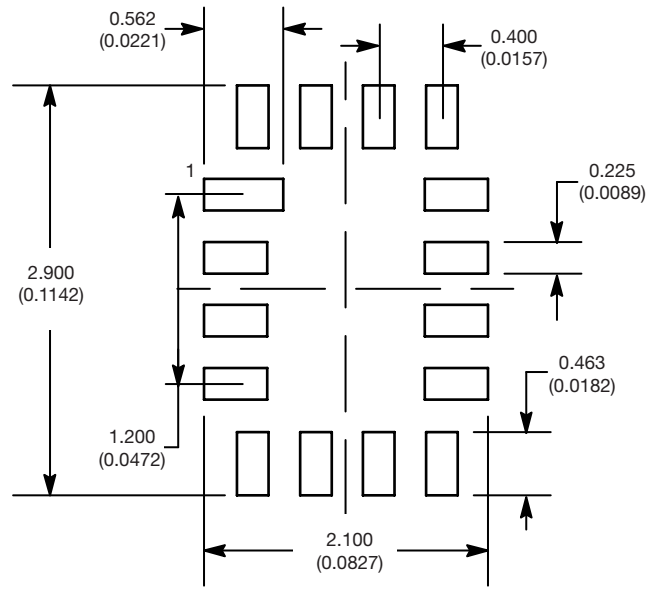

Mounting Footprint  
Dimensions in mm (inch)



## **Disclaimer**

ALL PRODUCT, PRODUCT SPECIFICATIONS AND DATA ARE SUBJECT TO CHANGE WITHOUT NOTICE TO IMPROVE RELIABILITY, FUNCTION OR DESIGN OR OTHERWISE.

Vishay Intertechnology, Inc., its affiliates, agents, and employees, and all persons acting on its or their behalf (collectively, "Vishay"), disclaim any and all liability for any errors, inaccuracies or incompleteness contained in any datasheet or in any other disclosure relating to any product.

Vishay makes no warranty, representation or guarantee regarding the suitability of the products for any particular purpose or the continuing production of any product. To the maximum extent permitted by applicable law, Vishay disclaims (i) any and all liability arising out of the application or use of any product, (ii) any and all liability, including without limitation special, consequential or incidental damages, and (iii) any and all implied warranties, including warranties of fitness for particular purpose, non-infringement and merchantability.

Statements regarding the suitability of products for certain types of applications are based on Vishay's knowledge of typical requirements that are often placed on Vishay products in generic applications. Such statements are not binding statements about the suitability of products for a particular application. It is the customer's responsibility to validate that a particular product with the properties described in the product specification is suitable for use in a particular application. Parameters provided in datasheets and / or specifications may vary in different applications and performance may vary over time. All operating parameters, including typical parameters, must be validated for each customer application by the customer's technical experts. Product specifications do not expand or otherwise modify Vishay's terms and conditions of purchase, including but not limited to the warranty expressed therein.

Hyperlinks included in this datasheet may direct users to third-party websites. These links are provided as a convenience and for informational purposes only. Inclusion of these hyperlinks does not constitute an endorsement or an approval by Vishay of any of the products, services or opinions of the corporation, organization or individual associated with the third-party website. Vishay disclaims any and all liability and bears no responsibility for the accuracy, legality or content of the third-party website or for that of subsequent links.

Except as expressly indicated in writing, Vishay products are not designed for use in medical, life-saving, or life-sustaining applications or for any other application in which the failure of the Vishay product could result in personal injury or death. Customers using or selling Vishay products not expressly indicated for use in such applications do so at their own risk. Please contact authorized Vishay personnel to obtain written terms and conditions regarding products designed for such applications.

No license, express or implied, by estoppel or otherwise, to any intellectual property rights is granted by this document or by any conduct of Vishay. Product names and markings noted herein may be trademarks of their respective owners.