

Low-side Switch ICs [Surface-mount 4-circuits] **SPF5002A**

Features

- DMOS 4ch output
- Allows ON/OFF using C-MOS logic level
- Built-in overcurrent, overvoltage and thermal protection circuits

Absolute Maximum Ratings

(Ta=25°C)

Parameter	Symbol	Ratings	Unit	Conditions
Power supply voltage	V _B	40	V	
Output terminal voltage	V _{OUT}	37	V	*
Input terminal voltage	V _{IN}	-0.5 to +7.5	V	
Output current	I _O	1.8	A	
Power Dissipation	P _D	2	W	
Storage temperature	T _{stg}	-40 to +150	°C	
Channel temperature	T _{ch}	150	°C	
Output avalanche capability	E _{AV}	50	mJ	Single pulse

Note: * At the clamping operation, refer to V_{OUT} (clamp) in the section of electrical characteristics.

External Dimensions (unit: mm)

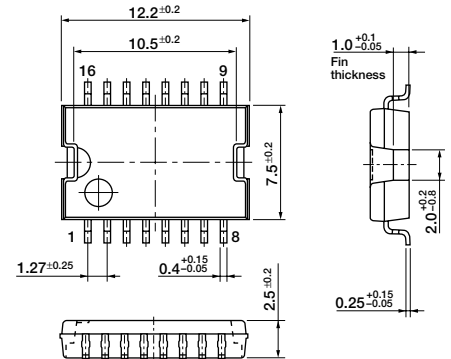

Electrical Characteristics

(V_B=14V, Ta=25°C unless otherwise specified)

Parameter	Symbol	Ratings			Unit	Conditions	
		min	typ	max			
Power supply voltage	V _{Bopr}	5.5		25	V		
Quiescent circuit current	I _q		5	7	mA	V _{IN} =0V (all inputs)	
Operating circuit current	I _{cc}		8	12	mA	V _{IN} =5V (all inputs)	
Input voltage	Hi output	V _{IN}	3.5		5.5	V	I _O =1A
	Lo output	V _{IN}	-0.5		1.5	V	
Input current	Hi output	I _{IN}			50	μA	V _{IN} =5V
	Lo output	I _{IN}			30	μA	V _{IN} =0V
Output ON resistance	R _{DS(ON)}			0.4	0.6	Ω	
				0.5	0.7	Ω	V _B =5.5V
Output clamp voltage	V _{OUT(clamp)}	41	50	55	V	I _O =1A	
Output leak current	I _{OH}			10	μA	V _O =37V	
Forward voltage of output stage diode	V _F			1.6	V	I _F =0.5A	
Overvoltage protection starting voltage	V _{B(ovp)}	25		40	V		
Thermal protection starting temperature	T _{TSD}	151	165		°C		
Overcurrent protection starting current	I _S	1.1			A		
Output transfer time	T _{ON}			12	μs	R _L =14Ω, I _O =1A	
	T _{OFF}			8	μs	R _L =14Ω, I _O =1A	
Output rise time	T _r			5	μs	R _L =14Ω, I _O =1A	
Output fall time	T _f			10	μs	R _L =14Ω, I _O =1A	

Equivalent Circuit Diagram

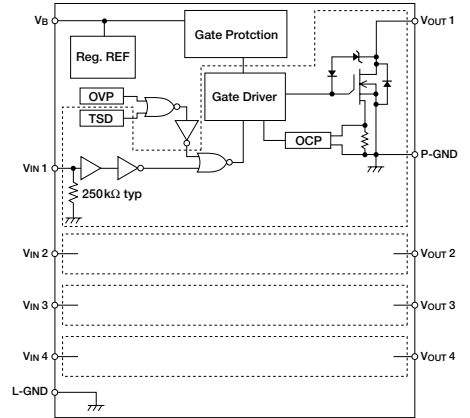

Circuit Example

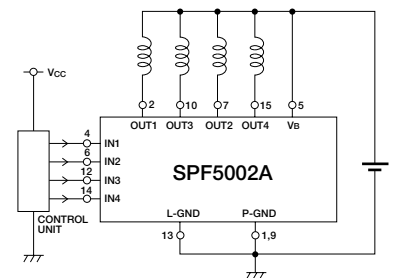

Truth table

V _{IN}	V _O
H	L
L	H

Use L-GND and P-GND being connected.

Timing Chart

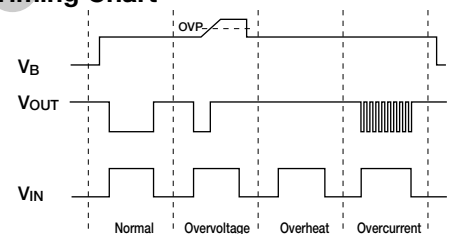

* Self-excited frequency is used in the overcurrent protection.

Electrical Characteristics

■ Quiescent Circuit Current

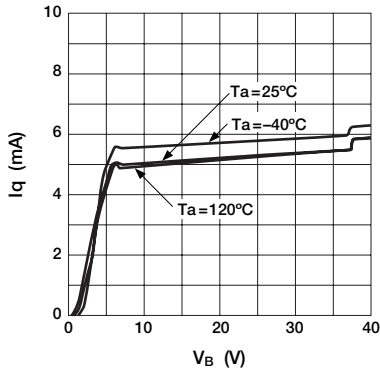

■ Circuit Current (single circuit)

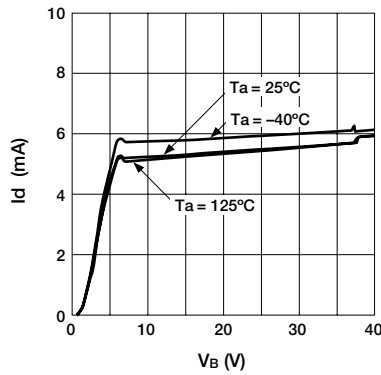

■ Circuit Current (4 circuits)

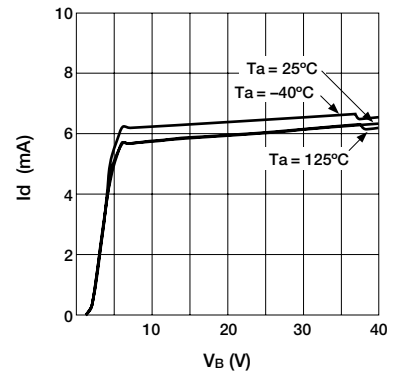

■ Threshold Input Voltage

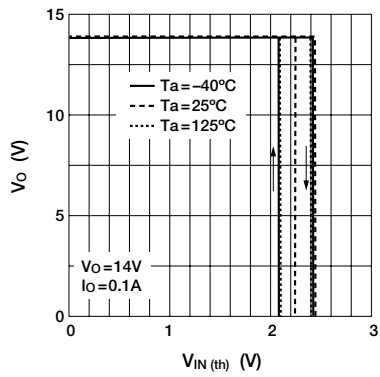

■ Output ON Voltage

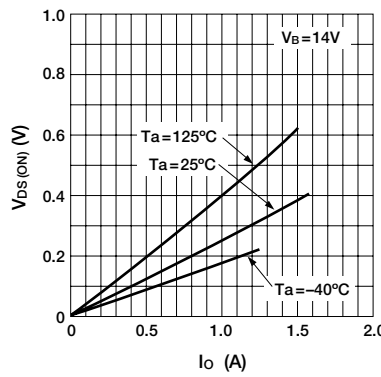

■ Forward Voltage of Output Stage Diode

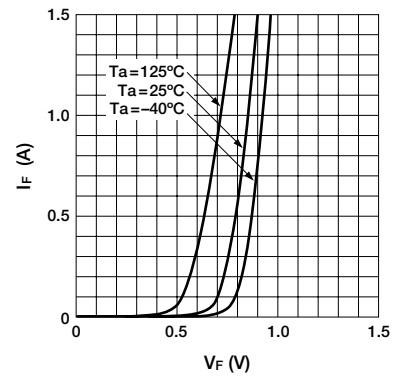

■ Overcurrent Protection Characteristics

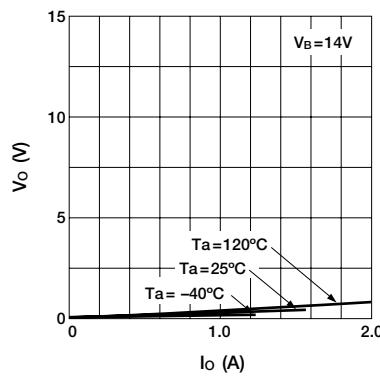

■ Overvoltage Protection Starting Voltage

