



Integrated Quad Half-bridge and Triple High Side with Embedded MCU and LIN for High End Mirror

The 908E621 is an integrated single package solution that includes a high performance HC08 microcontroller with a SMARTMOS analog control IC. The HC08 includes flash memory, a timer, enhanced serial communications interface (ESCI), a 10 bit analog-to-digital converter (ADC), internal serial peripheral interface (SPI), and an internal clock generator module (ICG). The analog control die provides four half-bridge and three high side outputs with diagnostic functions, a Hall effect sensor input, analog inputs, voltage regulator, window watchdog, and local interconnect network (LIN) physical layer.

The single package solution, together with LIN, provides optimal application performance adjustments and space saving PCB design. It is well-suited for the control of automotive high end mirrors.

Features

- High performance M68HC908EY16 core
- 16 KB of on-chip flash memory, 512 B of RAM
- Two 16-bit, two-channel timers
- LIN physical layer interface
- Autonomous MCU watchdog / MCU supervision
- One analog input with switchable current source
- Four low $R_{DS(ON)}$ half-bridge outputs
- Three low $R_{DS(ON)}$ high side outputs
- Wake-up and 2 or 3-pin Hall effect sensor input
- 12 microcontroller I/Os
- Pb-free packaging designated by suffix codes EK

908E621

QUAD HALF-BRIDGE AND TRIPLE HIGH SIDE SWITCH WITH EMBEDDED MCU AND LIN



ORDERING INFORMATION		
Device (Add an R2 suffix for Tape and reel orders)	Temperature Range (T _A)	Package
MM908E621ACPEK	-40 to 85°C	54 SOICW-EP

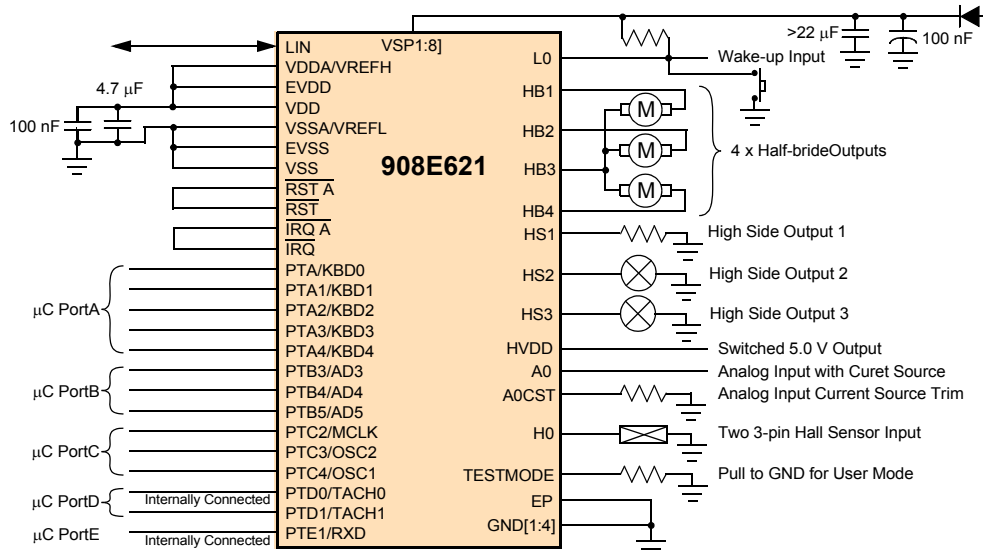

Figure 1. 908E621 Simplified Application Diagram

Freescale Semiconductor, Inc. reserves the right to change the detail specifications, as may be required, to permit improvements in the design of its products.

© Freescale Semiconductor, Inc., 2007-2012. All rights reserved.



INTERNAL BLOCK DIAGRAM

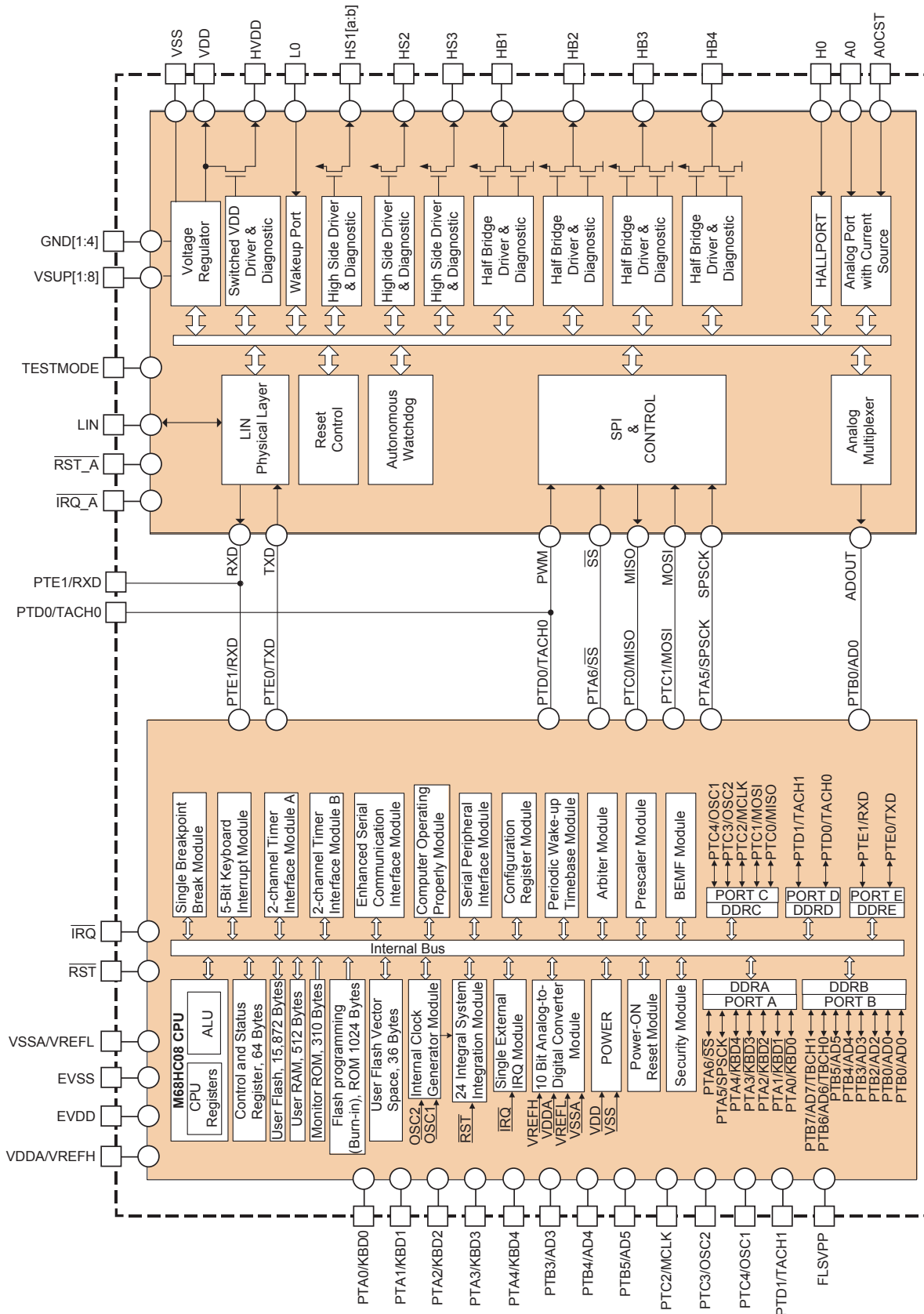

Figure 2. 908E621 Simplified Internal Block Diagram

PIN CONNECTIONS

Transparent Top
View of Package

Figure 3. Pin Connections

Table 1. Pin Definitions

A functional description of each pin can be found in the [Functional Pin Description](#) section beginning on page 19.

Die	Pin	Pin Name	Formal Name	Definition
MCU	1 2 3	PTC4/OSC1 PTC3/OSC2 PTC2/MCLK	Port C I/Os	These pins are special function, bidirectional I/O port pins that are shared with other functional modules in the MCU.
MCU	4 5 6	PTB5/AD5 PTB4/AD4 PTB3/AD3	Port B I/Os	These pins are special function, bidirectional I/O port pins that are shared with other functional modules in the MCU.
MCU	7	$\overline{\text{IRQ}}$	External Interrupt Input	This pin is an asynchronous external interrupt input pin.
MCU	8	$\overline{\text{RST}}$	External Reset	This pin is bidirectional, allowing a reset of the entire system. It is driven low when any internal reset source is asserted.
MCU / Analog	9	(PTD0/TACH0/BEMF -> PWM)	PWM signal	This pin is the PWM signal test pin. It internally connects the MCU PTD0/TACH0 pin with the Analog die PWM input. Note: Do not connect in the application.
MCU	10	PTD1/TACH1	Port D I/Os	This pin is a special function, bidirectional I/O port pin that is shared with other functional modules in the MCU.
MCU / Analog	44	(PTE1/RXD <- RXD)	LIN Transceiver Output	This pin is the LIN Transceiver output test pin. It internally connects the MCU PTE1/RXD pin with the Analog die LIN transceiver output pin RXD. Note: Do not connect in the application.

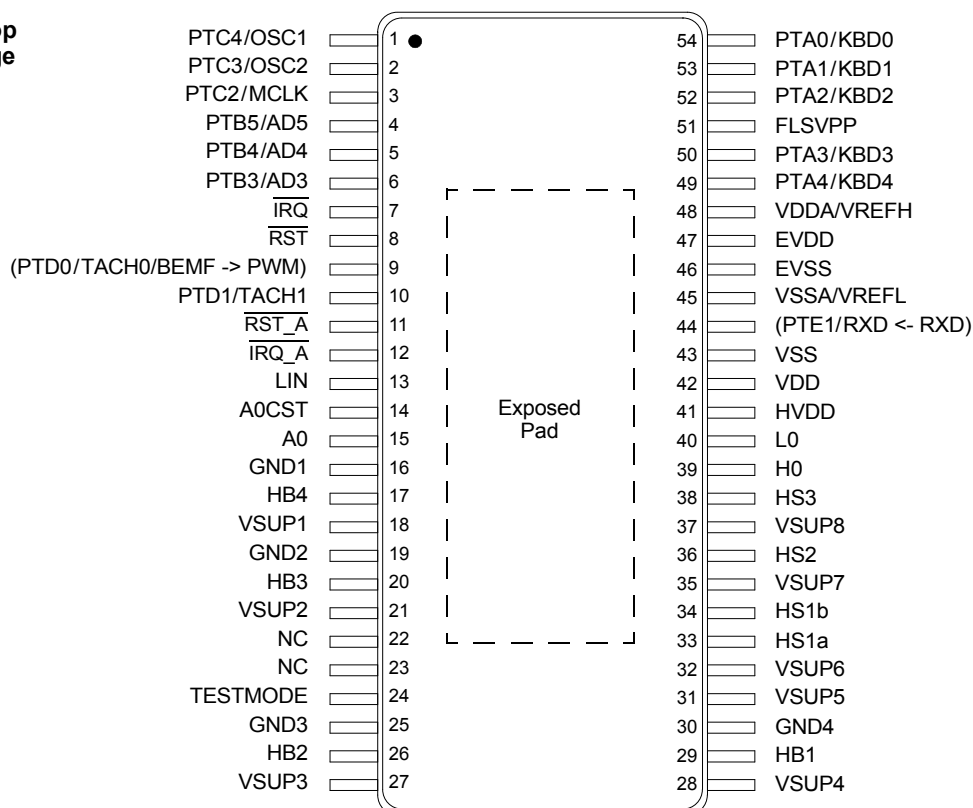
Table 1. Pin Definitions (continued)

A functional description of each pin can be found in the [Functional Pin Description](#) section beginning on page [19](#).

Die	Pin	Pin Name	Formal Name	Definition
MCU	45 48	VSSA/VREFL VDDA/VREFH	ADC Supply and Reference Pins	These pins are the power supply and voltage reference pins for the analog-to-digital converter (ADC).
MCU	46 47	EVSS EVDD	MCU Power Supply Pins	These pins are the ground and power supply pins, respectively. The MCU operates from a single power supply.
MCU	49 50 52 53 54	PTA4/KBD4 PTA3/KBD3 PTA2/KBD2 PTA1/KBD1 PTA0/KBD0	Port A I/Os	These pins are special function, bidirectional I/O port pins that are shared with other functional modules in the MCU.
MCU	51	FLSVPP	Test Pin	For test purposes only. Do not connect in the application.
Analog	11	$\overline{\text{RST_A}}$	Internal Reset	This pin is the bidirectional reset pin of the analog die.
Analog	12	$\overline{\text{IRQ_A}}$	Internal Interrupt Output	This pin is the interrupt output pin of the analog die indicating errors or wake-up events.
Analog	13	LIN	LIN Bus	This pin represents the single wire bus transmitter and receiver.
Analog	14	A0CST	Analog Input Trim Pin	This is the analog input trim pin for the A0 input. This is to connect a known fixed resistor value to trim the current source measurement.
Analog	15	A0	Analog Input Pin	This pin is an analog input port with selectable source values.
Analog	16 19 25 30	GND1 GND2 GND3 GND4	Power Ground Pins	These pins are device power ground connections.
Analog	29 26 20 17	HB1 HB2 HB3 HB4	Half-bridge Outputs	This device includes power MOSFETs configured as four half-bridge driver outputs. These outputs may be configured for DC motor drivers, or as high side and low side switches. Note: The HB3 and HB4 have a lower $R_{DS(ON)}$ than HB1 and HB2.
Analog	18 21 27 28 31 32 35	VSUP1 VSUP2 VSUP3 VSUP4 VSUP5 VSUP6 VSUP7	Power Supply Pins	These pins are device power supply pins.
–	22 23	NC NC	No Connect	These pins are not connected.
Analog	24	TESTMODE	TESTMODE Input	Pin for test purpose only. In application this pin needs to be tied GND.
Analog	34 35	HS1a HS1b	High Side HS1 Output	This output pin is a low $R_{DS(ON)}$ high side switch.
Analog	36 38	HS2 HS3	High Side HS2 Output High Side HS3 Output	These output pins are low $R_{DS(ON)}$ high side switches.
Analog	39	H0	Hall-Effect Sensor / General Purpose Input	This pin provides an input for a Hall-effect sensor or general purpose input.
Analog	40	L0	Wake-up Input	This pin provides an high voltage input, which is wake-up capable.
Analog	41	HVDD	Switchable V_{DD} Output	This pin is a switchable V_{DD} output for driving resistive loads requiring a regulated 5.0 V supply; e.g. potentiometers.
Analog	42	VDD	Voltage Regulator Output	The +5. V voltage regulator output pin is intended to supply the embedded microcontroller.

Table 1. Pin Definitions (continued)

A functional description of each pin can be found in the [Functional Pin Description](#) section beginning on page [19](#).

Die	Pin	Pin Name	Formal Name	Definition
Analog	43	VSS	Voltage Regulator Ground	Ground pin for the connection of all non-power ground connections (microcontroller and sensors).
–	EP	Exposed Pad	Exposed Pad	The exposed pad pin on the bottom side of the package conducts heat from the chip to the PCB board.

ELECTRICAL CHARACTERISTICS

MAXIMUM RATINGS

Table 2. Maximum Ratings

All voltages are with respect to ground, unless otherwise noted. Exceeding limits on any pin may cause permanent damage to the device.

Rating	Symbol	Value	Unit
ELECTRICAL RATINGS			
Supply Voltage			V
Analog Chip Supply Voltage under Normal Operation (Steady-state)	$V_{SUP(SS)}$	-0.3 to 28	
Analog Chip Supply Voltage under Transient Conditions ⁽¹⁾	$V_{SUP(PK)}$	-0.3 to 40	
MCU Chip Supply Voltage	V_{DD}	-0.3 to 5.5	
Input Pin Voltage			V
Analog Chip	$V_{IN(ANALOG)}$	-0.3 to 5.5	
Microcontroller Chip	$V_{IN(MCU)}$	$V_{SS}-0.3$ to $V_{DD}+0.3$	
Maximum Microcontroller Current per Pin			mA
All Pins except VDD, VSS, PTA0:PTA4	$I_{PIN(1)}$	±15	
PTA0:PTA4	$I_{PIN(2)}$	±25	
Maximum Microcontroller VSS Output Current	I_{MVSS}	100	mA
Maximum Microcontroller VDD Input Current	I_{MVDD}	100	mA
LIN Supply Voltage			V
Normal Operation (Steady-state)	$V_{BUS(SS)}$	-18 to 40	
Transient Input Voltage (per ISO7637 Specification) and with External Components (Figure 4 , page 16)	$V_{BUS(PK)}$	-150 to 100	
ESD Voltage ⁽²⁾			V
Human Body Model H0 pin	V_{ESD1-1}	±1000	
Human Body Model all other pins	V_{ESD1-2}	±2000	
Machine Model	V_{ESD2}	±200	
Charge Device Model	V_{ESD3}	±750	

Notes

1. Transient capability for pulses with a time of $t < 0.5$ sec.
2. ESD1 testing is performed in accordance with the Human Body Model ($C_{ZAP} = 100$ pF, $R_{ZAP} = 1500$ Ω), the Machine Model ($C_{ZAP} = 200$ pF, $R_{ZAP} = 0$ Ω) and the Charge Device Model, Robotic ($C_{ZAP} = 4.0$ pF).

Table 2. Maximum Ratings (continued)

All voltages are with respect to ground, unless otherwise noted. Exceeding limits on any pin may cause permanent damage to the device.

Rating	Symbol	Value	Unit
THERMAL RATINGS			
Operating Ambient Temperature ⁽³⁾	T_A	-40 to 85	°C
Operating Junction Temperature ⁽⁴⁾	T_J	-40 to 125	°C
Storage Temperature	T_{STG}	-40 to 150	°C
Peak Package Reflow Temperature During Reflow ^{(5), (6)}	T_{PPRT}	Note 6	°C

Notes

- The limiting factor is junction temperature; taking into account the power dissipation, thermal resistance, and heat sinking.
- The temperature of analog and MCU die is strongly linked via the package, but can differ in dynamic load conditions, usually because of higher power dissipation on the analog die. The analog die temperature must not exceed 150 °C under these conditions.
- Pin soldering temperature limit is for 10 seconds maximum duration. Not designed for immersion soldering. Exceeding these limits may cause malfunction or permanent damage to the device.
- Freescale's Package Reflow capability meets Pb-free requirements for JEDEC standard J-STD-020C. For Peak Package Reflow Temperature and Moisture Sensitivity Levels (MSL), Go to www.freescale.com, search by part number [e.g. remove prefixes/suffixes and enter the core ID to view all orderable parts. (i.e. MC33xxx enter 33xxx), and review parametrics.

STATIC ELECTRICAL CHARACTERISTICS

Table 3. Static Electrical Characteristics

All characteristics are for the analog chip only. Refer to the 68HC908EY16 datasheet for characteristics of the microcontroller chip. Characteristics noted under conditions $9.0\text{ V} \leq V_{\text{SUP}} \leq 16\text{ V}$, $-40\text{ }^\circ\text{C} \leq T_{\text{J}} \leq 125\text{ }^\circ\text{C}$, unless otherwise noted. Typical values noted reflect the approximate parameter mean at $T_{\text{A}} = 25\text{ }^\circ\text{C}$ under nominal conditions, unless otherwise noted.

Characteristic	Symbol	Min	Typ	Max	Unit
----------------	--------	-----	-----	-----	------

SUPPLY VOLTAGE RANGE

Nominal Operating Voltage	V_{SUP1}	9.0	—	16	V
Extended Operating Voltage (LIN only 8...18 V) ⁽⁸⁾	V_{SUP2}	7.5	—	20	V

SUPPLY CURRENT RANGE

Normal Mode ⁽⁸⁾ $V_{\text{SUP}} = 12\text{ V}$, Analog Chip in Normal Mode (PSON=1), MCU Operating Using Internal Oscillator at 32 MHz (8.0MHz Bus Frequency), SPI, ESCI, ADC Enabled	I_{RUN}	—	25	—	mA
Stop Mode ^{(8), (9)} $V_{\text{SUP}} = 12\text{ V}$, Voltage Regulator with limited current capability	I_{STOP}	—	40	50	μA
Sleep Mode ^{(8), (9)} $V_{\text{SUP}} = 12\text{ V}$, Voltage Regulator off	I_{SLEEP}	—	12	20	μA

DIGITAL INTERFACE RATINGS (ANALOG DIE)

Output pins $\overline{\text{RST_A}}$, $\overline{\text{IRQ_A}}$, RXD (MISO probe only) Low-state Output Voltage ($I_{\text{OUT}} = -1.5\text{ mA}$) High-state Output Voltage ($I_{\text{OUT}} = 250\text{ }\mu\text{A}$)	V_{OL} V_{OH}	— 3.85	— —	0.4 —	V
Output pin RXD - Capacitance ⁽¹⁰⁾	C_{OUT}	—	4.0	—	pF
Input pins $\overline{\text{RST_A}}$, PWM ($\overline{\text{SS}}$, MOSI, TXD probe only) Input Logic Low Voltage Input Logic High Voltage	V_{IL} V_{IH}	— 3.5	— —	1.5 —	V
Input pins - Capacitance ⁽¹⁰⁾	C_{IN}	—	4.0	—	pF
Pins $\overline{\text{IRQ_A}}$, $\overline{\text{RST_A}}$ - Pull-up Resistor	R_{PULLUP1}	—	10	—	k Ω
Pins $\overline{\text{SS}}$ - Pull-up Resistor	R_{PULLUP2}	—	100	—	k Ω
Pins MOSI, SPSCK, PWM - Pull-down Resistor	R_{PULLDOWN}	—	100	—	k Ω
Pin TXD - Pull-up Current Source	I_{PULLUP}	—	35	—	μA

Notes

7. Device is fully functional, but some of the parameters might be out of spec.
8. Total current measured at GND pins.
9. Stop and Sleep mode current will increase if V_{SUP} exceeds 15 V.
10. This parameter is guaranteed by process monitoring but is not production tested.

Table 3. Static Electrical Characteristics (continued)

All characteristics are for the analog chip only. Refer to the 68HC908EY16 datasheet for characteristics of the microcontroller chip. Characteristics noted under conditions $9.0\text{ V} \leq V_{\text{SUP}} \leq 16\text{ V}$, $-40\text{ }^\circ\text{C} \leq T_J \leq 125\text{ }^\circ\text{C}$, unless otherwise noted. Typical values noted reflect the approximate parameter mean at $T_A = 25\text{ }^\circ\text{C}$ under nominal conditions, unless otherwise noted.

Characteristic	Symbol	Min	Typ	Max	Unit
SYSTEM RESETS AND INTERRUPTS					
Low Voltage Reset (LVR)					
Threshold	V_{LVRON}	3.8	4.2	4.65	V
Hysteresis	$V_{\text{LVR_HYS}}$	50	–	300	mV
Low Voltage Interrupt (LVI)					V
Threshold	V_{LVION}	6.0	–	7.5	
Hysteresis	$V_{\text{LVI_HYS}}$	0.3	–	0.8	
High Voltage Interrupt (HVI)					V
Threshold	V_{HVION}	20	–	24	
Hysteresis	$V_{\text{HVI_HYS}}$	0.5	–	1.5	
High Temperature Interrupt (HTI) ⁽¹¹⁾					$^\circ\text{C}$
Threshold T_J	T_{ION}	125	–	150	
Hysteresis	T_{IH}	5.0	–	10.0	
High Temperature Reset (HTR) ⁽¹¹⁾					$^\circ\text{C}$
Threshold T_J	T_{RON}	155	–	180	
Hysteresis	T_{IH}	5.0	–	10.0	

VOLTAGE REGULATOR⁽¹²⁾

Normal Mode Output Voltage ⁽¹³⁾					V
$I_{\text{OUT}} = 60\text{ mA}$, $7.5\text{ V} < V_{\text{SUP}} < 20\text{ V}$	V_{DDRUN1}	4.75	5.0	5.25	
$I_{\text{OUT}} = 60\text{ mA}$, $V_{\text{SUP}} < 7.5\text{ V}$ and $V_{\text{SUP}} > 20\text{ V}$	V_{DDRUN2}	4.75	5.0	5.25	
Normal Mode Total Output Current	I_{OUTRUN}	–	120	150	mA
Load Regulation - $I_{\text{OUT}} = 60\text{ mA}$, $V_{\text{SUP}} = 9.0\text{ V}$, $T_J = 125\text{ }^\circ\text{C}$	V_{LR}	–	–	100	mV
STOP Mode Output Voltage ⁽¹³⁾	V_{DDSTOP}	4.75	5.0	5.25	V
STOP Mode Total Output Current	I_{OUTSTOP}	150	500	1100	μA

Notes

- This parameter is guaranteed by process monitoring but is not production tested.
- Specification with external low ESR ceramic capacitor $1.0\text{ }\mu\text{F} < C < 4.7\text{ }\mu\text{F}$ and $200\text{ m}\Omega \leq \text{ESR} \leq 10\text{ }\Omega$. Its not recommended to use capacitor values above $4.7\text{ }\mu\text{F}$
- When switching from Normal to Stop mode or from Stop mode to Normal mode, the output voltage can vary within the output voltage specification.

Table 3. Static Electrical Characteristics (continued)

All characteristics are for the analog chip only. Refer to the 68HC908EY16 datasheet for characteristics of the microcontroller chip. Characteristics noted under conditions $9.0\text{ V} \leq V_{\text{SUP}} \leq 16\text{ V}$, $-40\text{ }^\circ\text{C} \leq T_J \leq 125\text{ }^\circ\text{C}$, unless otherwise noted. Typical values noted reflect the approximate parameter mean at $T_A = 25\text{ }^\circ\text{C}$ under nominal conditions, unless otherwise noted.

Characteristic	Symbol	Min	Typ	Max	Unit
LIN PHYSICAL LAYER					
LIN Transceiver Output Voltage Recessive State, TXD HIGH, $I_{\text{OUT}} = 1.0\text{ }\mu\text{A}$ Dominant State, TXD LOW, 500 Ω External Pull-up Resistor	$V_{\text{LIN_REC}}$ $V_{\text{LIN_DOM}}$	$V_{\text{SUP}}-1$ —	— —	— 1.4	V
Normal Mode Pull-up Resistor to VSUP	R_{PU}	20	30	47	k Ω
Stop, Sleep Mode Pull-up Current Source	I_{PU}	—	20	—	μA
Output Current Shutdown Threshold	I_{BLIM}	100	230	280	mA
Output Current Shutdown Timing	I_{BLS}	5.0	—	40	μs
Leakage Current to GND V_{SUP} Disconnected, V_{BUS} at 18 V Recessive state, $8.0\text{ V} \leq V_{\text{SUP}} \leq 18\text{ V}$, $8.0\text{ V} \leq V_{\text{BUS}} \leq 18\text{ V}$, $V_{\text{BUS}} \geq V_{\text{SUP}}$ GND Disconnected, $V_{\text{GND}} = V_{\text{SUP}}$, V_{BUS} at -18 V	I_{BUS} $I_{\text{BUS-PAS-REC}}$ $I_{\text{BUS-NOGND}}$	— 0.0 -1.0	1.0 3.0 —	10 20 1.0	μA μA mA
LIN Receiver Receiver Threshold Dominant Receiver Threshold Recessive Receiver Threshold Center Receiver Threshold Hysteresis	$V_{\text{BUS_DOM}}$ $V_{\text{BUS_REC}}$ $V_{\text{BUS_CNT}}$ $V_{\text{BUS_HYS}}$	— 0.6 0.475 —	— — 0.5 —	0.4 — 0.525 0.175	VSUP

HIGH SIDE OUTPUT HS1

Switch On Resistance $T_J = 25\text{ }^\circ\text{C}$, $I_{\text{LOAD}} = 1.0\text{ A}$	$R_{\text{DS(ON)-HS1}}$	—	185	225	m Ω
Over-current Shutdown	I_{HSOC1}	6.0	—	9.0	A
Over-current Shutdown blanking time ⁽¹⁴⁾	t_{OCB}	—	4-8	—	μs
Current to Voltage Ratio ⁽¹⁵⁾ $V_{\text{ADOUT}} [\text{V}] / I_{\text{HS}} [\text{A}]$, (measured and trimmed $I_{\text{HS}} = 2.0\text{ A}$)	$\text{CR}_{\text{RATIOHS1}}$	0.84	1.2	1.56	V/A
High Side Switching Frequency ⁽¹⁴⁾	f_{PWMHS}	—	—	25	kHz
High Side Freewheeling Diode Forward Voltage $T_J = 25\text{ }^\circ\text{C}$, $I_{\text{LOAD}} = 1.0\text{ A}$	V_{HSF}	—	0.9	—	V
Leakage Current	I_{LeakHS}	—	<0.2	10	μA

Notes

14. This parameter is guaranteed by process monitoring but is not production tested.
15. This parameter is guaranteed only if correct trimming was applied.

Table 3. Static Electrical Characteristics (continued)

All characteristics are for the analog chip only. Refer to the 68HC908EY16 datasheet for characteristics of the microcontroller chip. Characteristics noted under conditions $9.0\text{ V} \leq V_{\text{SUP}} \leq 16\text{ V}$, $-40\text{ }^{\circ}\text{C} \leq T_J \leq 125\text{ }^{\circ}\text{C}$, unless otherwise noted. Typical values noted reflect the approximate parameter mean at $T_A = 25\text{ }^{\circ}\text{C}$ under nominal conditions, unless otherwise noted.

Characteristic	Symbol	Min	Typ	Max	Unit
HIGH SIDE OUTPUTS HS2 AND HS3⁽¹⁸⁾					
Switch On Resistance $T_J = 25\text{ }^{\circ}\text{C}$, $I_{\text{LOAD}} = 1.0\text{ A}$	$R_{\text{DS(ON)-HS23}}$	–	440	500	m Ω
Over-current Shutdown	I_{HSOC23}	3.6	–	5.6	A
Over-current Shutdown blanking time ⁽¹⁶⁾	t_{OCB}	–	4-8	–	μs
Current to Voltage Ratio ⁽¹⁷⁾ $V_{\text{ADOUT}} [\text{V}] / I_{\text{HS}} [\text{A}]$, (measured and trimmed $I_{\text{HS}} = 2.0\text{ A}$)	$\text{CR}_{\text{RATIOHS23}}$	1.16	1.66	2.16	V/A
High Side Switching Frequency ⁽¹⁶⁾	f_{PWMHS}	–	–	25	kHz
High Side Freewheeling Diode Forward Voltage $T_J = 25\text{ }^{\circ}\text{C}$, $I_{\text{LOAD}} = 1.0\text{ A}$	V_{HSF}	–	0.9	–	V
Leakage Current	I_{LEAKHS}	–	<0.2	10	μA
HALF-BRIDGE OUTPUTS HB1 AND HB2					
Switch On Resistance High Side, $T_J = 25\text{ }^{\circ}\text{C}$, $I_{\text{LOAD}} = 1.0\text{ A}$ Low Side, $T_J = 25\text{ }^{\circ}\text{C}$, $I_{\text{LOAD}} = 1.0\text{ A}$	$R_{\text{DS(ON)-HB12}}$	– –	750 750	900 900	m Ω
Over-current Shutdown High Side Low Side	I_{HBOC12}	1.0 1.0	– –	1.5 1.5	A
Over-current Shutdown blanking time ⁽¹⁹⁾	t_{OCB}	–	4-8	–	μs
Switching Frequency ⁽¹⁹⁾	f_{PWM}	–	–	25	kHz
Freewheeling Diode Forward Voltage High Side, $T_J = 25\text{ }^{\circ}\text{C}$, $I_{\text{LOAD}} = 1.0\text{ A}$ Low Side, $T_J = 25\text{ }^{\circ}\text{C}$, $I_{\text{LOAD}} = 1.0\text{ A}$	V_{HSF} V_{LSF}	– –	0.9 0.9	– –	V
Leakage Current	I_{LEAKHB}	–	<0.2	10	μA
Low Side Current to Voltage Ratio ⁽²⁰⁾ $V_{\text{ADOUT}} [\text{V}] / I_{\text{HB}} [\text{A}]$, CSA = 1, (measured and trimmed $I_{\text{HB}} = 200\text{ mA}$) $V_{\text{ADOUT}} [\text{V}] / I_{\text{HB}} [\text{A}]$, CSA = 0, (measured and trimmed $I_{\text{HB}} = 500\text{ mA}$)	$\text{CR}_{\text{RATIOHB12}}$	17.5 3.5	25.0 5.0	32.5 6.5	V/A

Notes

16. This parameter is guaranteed by process monitoring but is not production tested.
17. This parameter is guaranteed only if correct trimming was applied.
18. The high side HS3 can be only used for resistive loads.
19. This parameter is guaranteed by process monitoring but is not production tested.
20. This parameter is guaranteed only if correct trimming was applied

Table 3. Static Electrical Characteristics (continued)

All characteristics are for the analog chip only. Refer to the 68HC908EY16 datasheet for characteristics of the microcontroller chip. Characteristics noted under conditions $9.0\text{ V} \leq V_{\text{SUP}} \leq 16\text{ V}$, $-40\text{ }^\circ\text{C} \leq T_J \leq 125\text{ }^\circ\text{C}$, unless otherwise noted. Typical values noted reflect the approximate parameter mean at $T_A = 25\text{ }^\circ\text{C}$ under nominal conditions, unless otherwise noted.

Characteristic	Symbol	Min	Typ	Max	Unit
HALF-BRIDGE OUTPUTS HB3 AND HB4					
Switch On Resistance High Side, $T_J = 25\text{ }^\circ\text{C}$, $I_{\text{LOAD}} = 1.0\text{ A}$ Low Side, $T_J = 25\text{ }^\circ\text{C}$, $I_{\text{LOAD}} = 1.0\text{ A}$	$R_{\text{DS(ON)-HB34}}$	–	275	325	$\text{m}\Omega$
Over-current Shutdown High Side Low Side	I_{HBOC34}	4.8 4.8	– –	7.2 7.2	A
Over-current Shutdown blanking time ⁽²¹⁾	t_{OCB}	–	4-8	–	μs
Switching Frequency ⁽²¹⁾	f_{PWM}	–	–	25	kHz
Freewheeling Diode Forward Voltage High Side, $T_J = 25\text{ }^\circ\text{C}$, $I_{\text{LOAD}} = 1.0\text{ A}$ Low Side, $T_J = 25\text{ }^\circ\text{C}$, $I_{\text{LOAD}} = 1.0\text{ A}$	V_{HSF} V_{LSF}	– –	0.9 0.9	– –	V
Leakage Current	I_{LEAKHB}	–	<0.2	10	μA
Low Side Current to Voltage Ratio ⁽²²⁾ $V_{\text{ADOUT}} [\text{V}] / I_{\text{HB}} [\text{A}]$, CSA = 1, (measured and trimmed $I_{\text{HB}} = 500\text{ mA}$) $V_{\text{ADOUT}} [\text{V}] / I_{\text{HB}} [\text{A}]$, CSA = 0, (measured and trimmed $I_{\text{HB}} = 2.0\text{ A}$)	$\text{CR}_{\text{RATIOHB34}}$	3.5 0.7	5.0 1.0	6.5 1.3	V/A

SWITCHABLE V_{DD} OUTPUT HVDD

Over-current Shutdown	I_{HVDDOC}	25	35	50	mA
Over-current Shutdown Blanking Time ⁽²³⁾ HVDDT1:0 = 00 HVDDT1:0 = 01 HVDDT1:0 = 10 HVDDT1:0 = 11	t_{HVDDOCB}	– – – –	950 536 234 78	– – – –	μs
Over-current Flag Delay ⁽²³⁾	t_{HVDDOCFD}	–	0.5	–	ms
Dropout Voltage @ $I_{\text{LOAD}} = 20\text{ mA}$	V_{HVDDDROP}	–	110	300	mV

V_{SUP} DOWN SCALER⁽²⁴⁾

Voltage Ratio (RATIO $V_{\text{SUP}} = V_{\text{SUP}} / V_{\text{ADOUT}}$)	$\text{RATIO}_{\text{VSUP}}$	4.75	5.0	5.25	–
---	------------------------------	------	-----	------	---

INTERNAL DIE TEMPERATURE SENSOR⁽²⁴⁾

Voltage / Temperature Slope ⁽²³⁾	S_{TTOV}	–	26	–	$\text{mV}/^\circ\text{C}$
Output Voltage @25°C	V_{T25}	1.7	1.9	2.1	V

Notes

21. This parameter is guaranteed by process monitoring but is not production tested.
22. This parameter is guaranteed only if correct trimming was applied
23. This parameter is guaranteed by process monitoring but is not production tested.
24. This parameter is guaranteed only if correct trimming was applied

Table 3. Static Electrical Characteristics (continued)

All characteristics are for the analog chip only. Refer to the 68HC908EY16 datasheet for characteristics of the microcontroller chip. Characteristics noted under conditions $9.0\text{ V} \leq V_{\text{SUP}} \leq 16\text{ V}$, $-40\text{ }^\circ\text{C} \leq T_{\text{J}} \leq 125\text{ }^\circ\text{C}$, unless otherwise noted. Typical values noted reflect the approximate parameter mean at $T_{\text{A}} = 25\text{ }^\circ\text{C}$ under nominal conditions, unless otherwise noted.

Characteristic	Symbol	Min	Typ	Max	Unit
----------------	--------	-----	-----	-----	------

HALL-EFFECT SENSOR INPUT H0 - GENERAL PURPOSE INPUT MODE (H0MS = 0)

Input Voltage Low Threshold	V_{LT}	–	–	1.5	V
Input Voltage High Threshold	V_{HT}	3.5	–	–	V
Input Voltage Hysteresis	V_{HH}	100	–	500	mV
Pull-up resistor	R_{PH}	7.0	10	13	k Ω

HALL-EFFECT SENSOR INPUT H0 - 2PIN HALL SENSOR INPUT MODE (H0MS = 1)

Output Voltage $V_{\text{SUP}} < 17\text{ V}$ $V_{\text{SUP}} > 17\text{ V}$	V_{HALL1} V_{HALL2}	– –	$V_{\text{SUP}}-1.2$ –	– 15.8	V
Output Drop @ $I_{\text{OUT}} = 15\text{ mA}$	V_{H0D}	–	–	2.5	V
Sense Current Threshold	I_{HSCT}	6.0	7.9	10	mA
Sense Current Hysteresis	I_{HSCH}	650	–	1650	μA
Sense Current Limitation	V_{HSCLIM}	20	40	70	mA

ANALOG INPUT A0, A0CST

Current Source A0, A0CST ^{(25), (26)} CSSEL1:0 = 00 CSSEL1:0 = 01 CSSEL1:0 = 10 CSSEL1:0 = 11	I_{CS1} I_{CS2} I_{CS3} I_{CS4}	– – – –	40 120 320 800	– – – –	μA
--	--	------------------	-------------------------	------------------	---------------

WAKE-UP INPUT L0

Input Voltage Threshold Low	V_{LT}	–	–	1.5	V
Input Voltage Threshold High	V_{HT}	3.5	–	–	V
Input Voltage Hysteresis	V_{LH}	0.5	–	–	V
Input Current	I_{N}	-10	–	10	μA
Wake-up Filter Time ⁽²⁷⁾	t_{WUP}	–	20	–	μs

Notes

25. This parameter is guaranteed only if correct trimming was applied
26. The current values are optimized to read a NTC temperature sensor, e.g. EPCOS type B57861 ($R_{25} = 3000\Omega$, R/T characteristic 8016)
27. This parameter is guaranteed by process monitoring but is not production tested.

DYNAMIC ELECTRICAL CHARACTERISTICS

Table 4. Dynamic Electrical Characteristics

All characteristics are for the analog chip only. Please refer to the 68HC908EY16 datasheet for characteristics of the microcontroller chip. Characteristics noted under conditions $9.0V \leq V_{SUP} \leq 16V$, $-40^{\circ}C \leq T_J \leq 125^{\circ}C$, unless otherwise noted. Typical values noted reflect the approximate parameter mean at $T_A = 25^{\circ}C$ under nominal conditions, unless otherwise noted.

Characteristic	Symbol	Min	Typ	Max	Unit
----------------	--------	-----	-----	-----	------

LIN PHYSICAL LAYER

Driver Characteristics for Normal Slew Rate^{(28), (29)}

Dominant Propagation Delay TXD to LIN	$t_{DOM-MIN}$	—	—	50	μs
Dominant Propagation Delay TXD to LIN	$t_{DOM-MAX}$	—	—	50	μs
Recessive Propagation Delay TXD to LIN	$t_{REC-MIN}$	—	—	50	μs
Recessive Propagation Delay TXD to LIN	$t_{REC-MAX}$	—	—	50	μs
Duty Cycle 1: $D1 = t_{BUS_REC(MIN)} / (2 \times t_{BIT})$, $t_{BIT} = 50 \mu s$, $V_{SUP} = 7.0 V \dots 18 V$	D1	0.396	—	—	
Duty Cycle 2: $D2 = t_{BUS_REC(MAX)} / (2 \times t_{BIT})$, $t_{BIT} = 50 \mu s$, $V_{SUP} = 7.6 V \dots 18 V$	D2	—	—	0.581	

Driver Characteristics for Slow Slew Rate^{(28), (30)}

Dominant Propagation Delay TXD to LIN	$t_{DOM-MIN}$	—	—	100	μs
Dominant Propagation Delay TXD to LIN	$t_{DOM-MAX}$	—	—	100	μs
Recessive Propagation Delay TXD to LIN	$t_{REC-MIN}$	—	—	100	μs
Recessive Propagation Delay TXD to LIN	$t_{REC-MAX}$	—	—	100	μs
Duty Cycle 3: $D3 = t_{BUS_REC(MIN)} / (2 \times t_{BIT})$, $t_{BIT} = 96 \mu s$, $V_{SUP} = 7.0 V \dots 18 V$	D3	0.417	—	—	
Duty Cycle 4: $D4 = t_{BUS_REC(MAX)} / (2 \times t_{BIT})$, $t_{BIT} = 96 \mu s$, $V_{SUP} = 7.6 V \dots 18 V$	D4	—	—	0.590	

Driver Characteristics for Fast Slew Rate

LIN High Slew Rate (Programming Mode)	SR_{FAST}	—	20	—	$V/\mu s$
---------------------------------------	-------------	---	----	---	-----------

Receiver Characteristics and Wake-up Timings

Receiver Dominant Propagation Delay ⁽³¹⁾	t_{RL}	—	3.5	6.0	μs
Receiver Recessive Propagation Delay ⁽³¹⁾	t_{RH}	—	3.5	6.0	μs
Receiver Propagation Delay Symmetry	t_{R-SYM}	-2.0	—	2.0	μs
Bus Wake-up Deglitcher	t_{PROPWL}	30	50	150	μs
Bus Wake-up Event Reported ⁽³²⁾	t_{WAKE}	—	20	—	μs

Notes

28. V_{SUP} from 7.0 to 18 V, bus load R0 and C0 1.0 nF/1.0 k Ω , 6.8 nF/660 Ω , 10 nF/500 Ω . Measurement thresholds: 50% of TXD signal to LIN signal threshold defined at each parameter.
29. See [Figure 6](#), page 16.
30. See [Figure 7](#), page 17.
31. Measured between LIN signal threshold V_{IL} or V_{IH} and 50% of RXD signal.
32. t_{WAKE} is typically 2 internal clock cycles after LIN rising edge detected. See [Figure 9](#) and [Figure 8](#), page 17. In Sleep mode the V_{DD} rise time is strongly dependent upon the decoupling capacitor at VDD pin.

Table 4. Dynamic Electrical Characteristics (continued)

All characteristics are for the analog chip only. Please refer to the 68HC908EY16 datasheet for characteristics of the microcontroller chip. Characteristics noted under conditions $9.0V \leq V_{SUP} \leq 16V$, $-40^{\circ}C \leq T_J \leq 125^{\circ}C$, unless otherwise noted. Typical values noted reflect the approximate parameter mean at $T_A = 25^{\circ}C$ under nominal conditions, unless otherwise noted.

Characteristic	Symbol	Min	Typ	Max	Unit
SPI INTERFACE TIMING					
SPI Operating Recommended Frequency ⁽³³⁾	$f_{SPIO P}$	0.25	—	4.0	MHz

State Machine

Reset Low Level Duration after V_{DD} High	t_{RST}	0.8	1.25	1.94	ms
Normal Request Timeout	$t_{NORMREQ}$	51	80	150	ms

Window Watchdog Timer⁽³⁴⁾

Watchdog Period (WDP1:0 = 00)	t_{WD80}	52	80	124	ms
Watchdog Period (WDP1:0 = 01)	t_{WD40}	26	40	62	ms
Watchdog Period (WDP1:0 = 10)	t_{WD20}	13	20	31	ms
Watchdog Period (WDP1:0 = 11)	t_{WD10}	6.5	10	15.5	ms

Notes

33. This parameter is guaranteed by process monitoring but is not production tested.
 34. This parameter is guaranteed only if correct trimming was applied. Additionally [See Watchdog Period Range Value \(AWD Trim\) on page 46](#)

MICROCONTROLLER PARAMETRICS**Table 5. Microcontroller**

For a detailed microcontroller description, refer to the MC68HC908EY16 datasheet.

Module	Description
Core	High Performance HC08 Core with a Maximum Internal Bus Frequency of 8.0 MHz
Timer	Two 16-Bit Timers with 2 Channels (TIM A and TIM B)
Flash	16 k Bytes
RAM	512 Bytes
ADC	10-Bit Analog-to-Digital Converter
SPI	SPI Module
ESCI	Standard Serial Communication Interface (SCI) Module Bit-Time Measurement Arbitration Prescaler with Fine Baud Rate Adjustment
ICG	Internal Clock Generation Module

TIMING DIAGRAMS

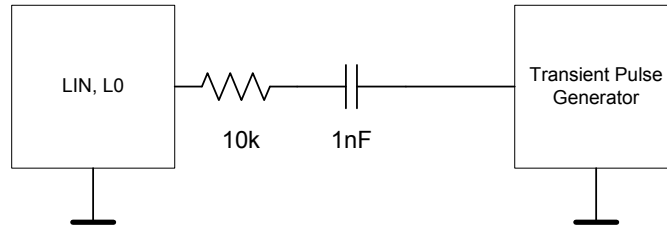

Note: Waveform in accordance to ISO7637 part 1, test pulses 1, 2, 3a and 3b.

Figure 4. Test Circuit for Transient Test Pulses

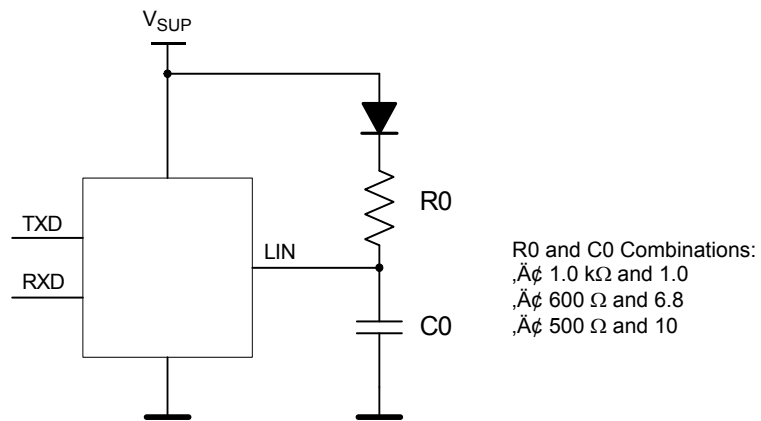

Figure 5. Test Circuit for LIN Timing Measurements

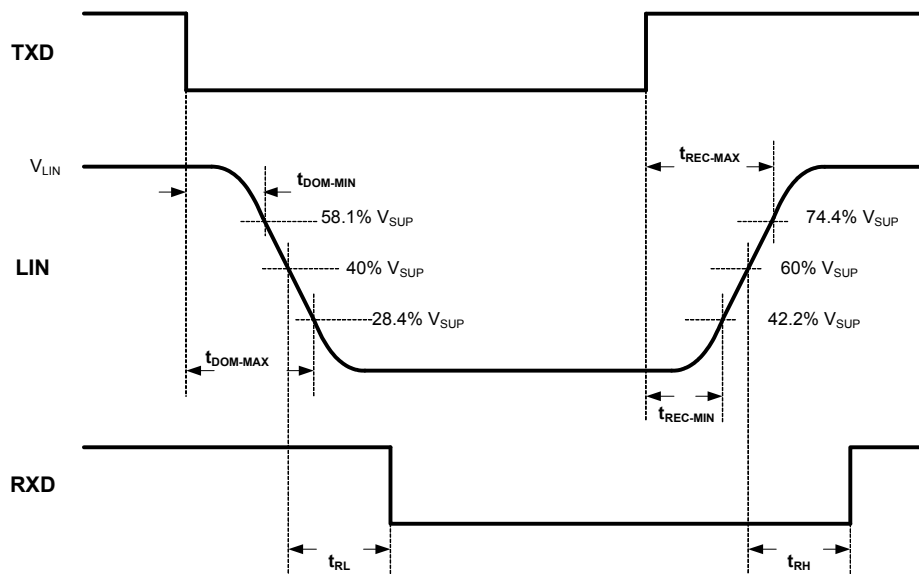

Figure 6. LIN Timing Measurements for Normal Slew Rate

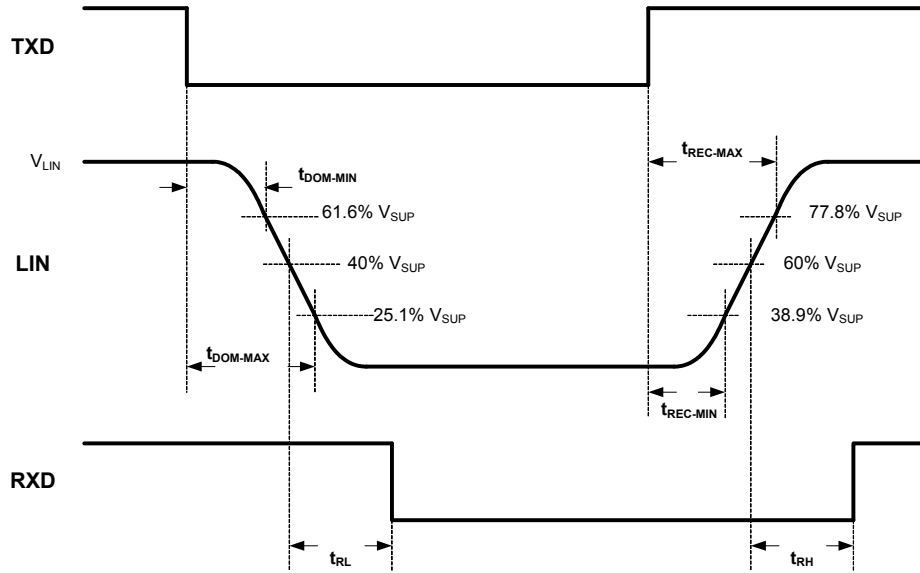

Figure 7. LIN Timing Measurements for Slow Slew Rate

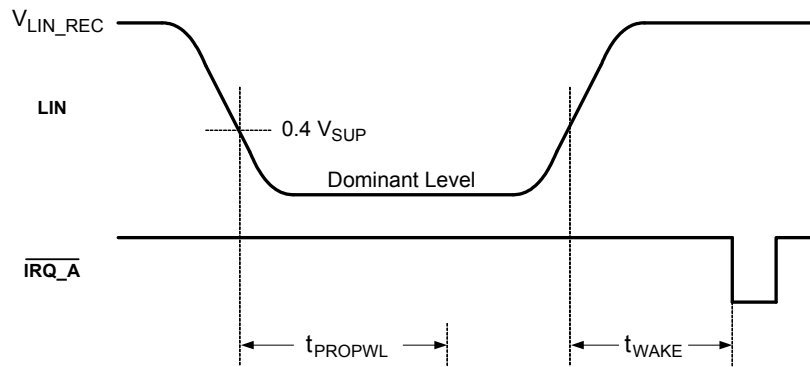

Figure 8. Wake-up Stop Mode Timing

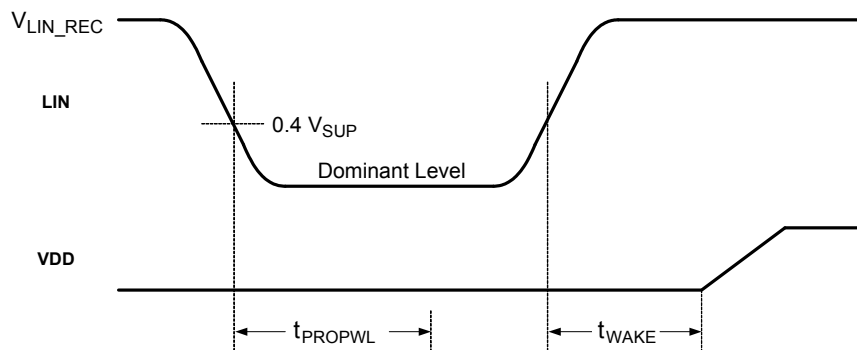

Figure 9. Wake-up Sleep Mode Timing

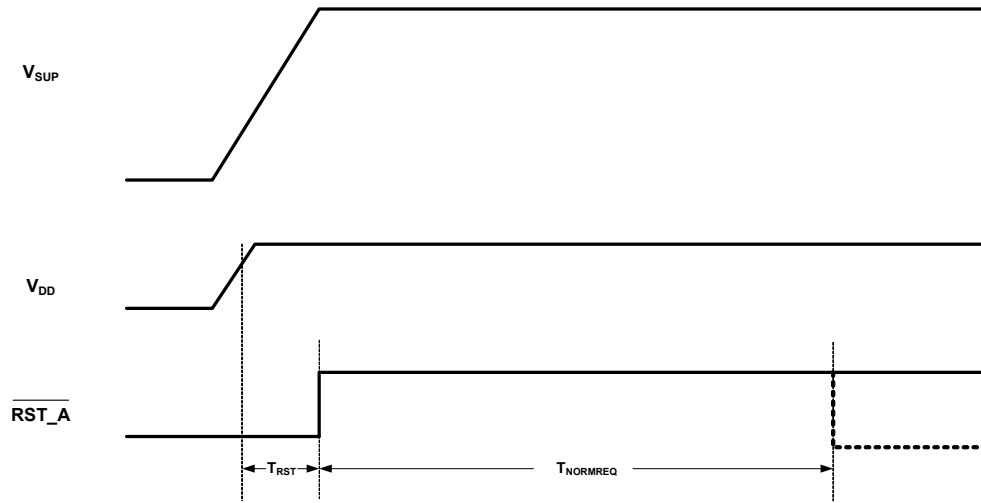

Figure 10. Power On Reset and Normal Request Timeout Timing

FUNCTIONAL DESCRIPTION

INTRODUCTION

The 908E621 was designed and developed as a highly integrated and cost-effective solution for automotive and industrial applications. For automotive body electronics, the 908E621 is well suited to perform complete mirror control via a three wire LIN bus.

This device combines an HC908EY16 MCU core with flash memory together with a *SMARTMOS* IC chip. The *SMARTMOS* IC chip combines power and control in one chip. Power switches are provided on the *SMARTMOS* IC configured as half-bridge outputs and three high side

switches. Other ports are also provided, which include one Hall-effect sensor input port, one analog input port with a switched current source, one wake-up pin, and a selectable HVDD pin. An internal voltage regulator provides power to the MCU chip.

Also included in this device is a LIN physical layer, which communicates using a single wire. This enables this device to be compatible with three wire bus systems, where one wire is used for communication, one for battery, and one for ground.

FUNCTIONAL PIN DESCRIPTION

See [Figure 2, 908E621 Simplified Internal Block Diagram](#), page 2, for a graphic representation of the various pins referred to in the following paragraphs. Also, see the pin diagram on [page 3](#) for a depiction of the pin locations on the package.

PORT A I/O PINS

These pins are special function, bidirectional I/O port pins that are shared with other functional modules in the MCU. PTA0:PTA4 are shared with the keyboard interrupt pins, KBD0:KBD4.

The PTA5/SPSCK pin is not accessible in this device and is internally connected to the SPI clock pin of the analog die.

The PTA6/ \overline{SS} pin is not accessible in this device and is internally connected to the SPI slave select input of the analog die.

For details refer to the 68HC908EY16 datasheet.

PORT B I/O PINS

These pins are special function, bidirectional I/O port pins that are shared with other functional modules in the MCU. All pins are shared with the ADC module.

PTB0/AD0 is internally connected to the ADOUT pin of the analog die, allowing diagnostic measurements to be calculated (e.g., current recopy, V_{SUP} , etc.).

The PTB1/AD1, PTB2/AD2, PTB6/AD6/TBCH0, PTB7/AD7/TBCH1 pins are not accessible in this device.

For details refer to the 68HC908EY16 datasheet.

PORT C I/O PINS

These pins are special function, bidirectional I/O port pins that are shared with other functional modules in the MCU. For example, PTC2:PTC4 are shared with the ICG module.

PTC0/MISO and PTC1/MOSI are not accessible in this device and are internally connected to the MISO and MOSI SPI pins of the analog die.

For details refer to the 68HC908EY16 datasheet.

PORT D I/O PINS

PTD0/TACH0/BEMF and PTD1/TACH1 are special function, bi-directional I/O port pins that can also be programmed to be timer pins.

PTD0/TACH0 pin is internally connected to the PWM input of the analog die and only accessible for test purposes (can not be used in the application).

For details refer to the 68HC908EY16 datasheet.

PORT E I/O PIN

PTE0/TXD and PTE1/RXD are special function, bidirectional I/O port pins that can also be programmed to be enhanced serial communication.

PTE0/TXD is internally connected to the TXD pin of the analog die. The connection for the receiver must be done externally.

PTE1/RXD is internally connected to the RXD pin of the analog die and only accessible for test purposes (can not be used in the application).

For details refer to the 68HC908EY16 datasheet.

EXTERNAL INTERRUPT PIN (\overline{IRQ})

The \overline{IRQ} pin is an asynchronous external interrupt pin. This pin contains an internal pull-up resistor that is always activated, even when the \overline{IRQ} pin is pulled LOW.

For details refer to the 68HC908EY16 datasheet.

EXTERNAL RESET PIN ($\overline{\text{RST}}$)

A logic [0] on the $\overline{\text{RST}}$ pin forces the MCU to a known startup state. $\overline{\text{RST}}$ is bidirectional, allowing a reset of the entire system. It is driven LOW when any internal reset source is asserted.

This pin contains an internal pull-up resistor that is always activated, even when the reset pin is pulled LOW.

For details refer to the 68HC908EY16 datasheet.

POWER SUPPLY PINS (VSUP1:VSUP8)

VSUP1:VSUP8 are device power supply pins. The nominal input voltage is designed for operation from 12 V systems. Owing to the low ON-resistance and current requirements of the half-bridge driver outputs and high side output drivers, multiple VSUP pins are provided.

All VSUP pins must be connected to get full chip functionality.

POWER GROUND PINS (GND1:GND4)

GND1:GND4 are device power ground connections. Owing to the low ON-resistance and current requirements of the half-bridge driver outputs and high side output drivers, multiple pins are provided.

GND1 and GND2 pins must be connected to get full chip functionality.

HALF-BRIDGE OUTPUT PINS (HB1:HB4)

The 908E621 device includes power MOSFETs configured as four half-bridge driver outputs. The HB3:HB4 have a lower $R_{\text{DS(ON)}}$, to run higher currents (e.g. fold motor), than the HB1:B2 outputs.

The HB1:HB4 outputs are short-circuit and over-temperature protected, and they feature current recopy. Over-current protection is done on both high side and low side FET's. The current recopy are done on the low side MOSFETs.

HIGH SIDE OUTPUT PINS (HS1:HS3)

The HS output pins are a low $R_{\text{DS(ON)}}$ high side switches. Each HS switch is protected against over-temperature and over-current. The output is capable of limiting the inrush current with an automatic PWM or feature a real PWM capability using the PWM input.

The HS1 has a lower $R_{\text{DS(ON)}}$, to run higher currents (e.g. heater), than the HS2 and HS3 outputs.

For the HS1 two pins (HS1a:HS1b) are necessary for the current capability and have to be connected externally.

Important: The HS3 can be only used to drive resistive loads.

HALL-EFFECT SENSOR INPUT PIN (H0)

The Hall-effect sensor input pin H0 provides an input for Hall-effect sensors (2-pin or 3-pin) or a switch.

ANALOG INPUT PINS (A0, A0CST)

These pins are analog inputs with selectable current source values. The A0CST intent is to trim the A0 input.

WAKE-UP INPUT PIN (L0)

This pin is 40 V rated input. It can be used as wake-up source for a system wake-up. The input is falling or rising edge sensitive.

Important: If unused this pin should be connected to VSUP or GND to avoid parasitic transitions. In Low Power mode this could lead to random wake-up events.

SWITCHABLE V_{DD} OUTPUT PIN (HVDD)

The HVDD pin is a switchable V_{DD} output for driving resistive loads requiring a regulated 5.0 V supply (e.g., 3 pin Hall-effect sensors or potentiometers). The output is short-circuit protected.

LIN BUS PIN (LIN)

The LIN pin represents the single wire bus transmitter and receiver. It is suited for automotive bus systems and is based on the LIN bus specification.

+5.0 V VOLTAGE REGULATOR OUTPUT PIN (VDD)

The VDD pin is needed to place an external capacitor to stabilize the regulated output voltage. The VDD pin is intended to supply the embedded microcontroller.

Important: The VDD pin should not be used to supply other loads; use the HVDD pin for this purpose. The VDD, EVDD and VDDA/VREFH pins must be connected together.

VOLTAGE REGULATOR GROUND PIN (VSS)

The VSS pin is the ground pin for the connection of all non-power ground connections (microcontroller and sensors).

Important: VSS, EVSS and VSSA/VREFL pins must be connected together.

RESET PIN ($\overline{\text{RST_A}}$)

$\overline{\text{RST_A}}$ is the bidirectional reset pin of the analog die. It is an open drain with pullup resistor and must be connected to the $\overline{\text{RST}}$ pin of the MCU.

INTERRUPT PIN ($\overline{\text{IRQ_A}}$)

$\overline{\text{IRQ_A}}$ is the interrupt output pin of the analog die indicating errors or wake-up events. It is an open drain with pullup resistor and must be connected to the $\overline{\text{IRQ}}$ pin of the MCU.

ADC SUPPLY/REFERENCE PINS (VDDA/VREFH AND VSSA/VREFL)

VDDA and VSSA are the power supply pins for the analog-to-digital converter (ADC).

VREFH and VREFL are the reference voltage pins for the ADC.

The supply and reference signals are internally connected.

It is recommended that a high quality ceramic decoupling capacitor be placed between these pins.

For details refer to the 68HC908EY16 datasheet.

MCU POWER SUPPLY PINS (EVDD AND EVSS)

EVDD and EVSS are the power supply and ground pins. The MCU operates from a single power supply.

Fast signal transitions on MCU pins place high, short-duration current demands on the power supply. To prevent noise problems, take special care to provide power supply bypassing at the MCU.

For details refer to the 68HC908EY16 datasheet.

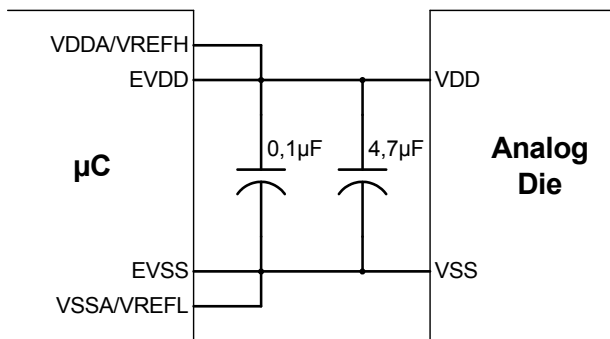

TEST MODE PIN (TESTMODE)

This pin is for test purpose only. In the application this pin has to be forced to GND.

For Programming/Test this pin has to be forced to V_{DD} to bring the analog die into Test mode. In Test mode the Reset Timeout (80 ms) is disabled and the LIN receiver is disabled.

NOTE: After detecting a RESET (internal or external), the PSON bit needs to be set within 80 ms. If not, the device will automatically enter sleep mode.

MCU TEST PIN (FLSVPP)

This pin is for test purposes only. This pin should either be left open (not connected) or can be connected to GND.

NO CONNECT PINS (NC)

The NC pins are not connected internally.

Note: Each of the NC pins can be left open or connected to ground (recommended).

EXPOSED PAD PIN

The exposed pad pin on the bottom side of the package conducts heat from the chip to the PCB board. For thermal performance, the pad must be soldered to the PCB board. It is recommended that the pad be connected to the ground potential.

FUNCTIONAL INTERNAL BLOCK DESCRIPTION

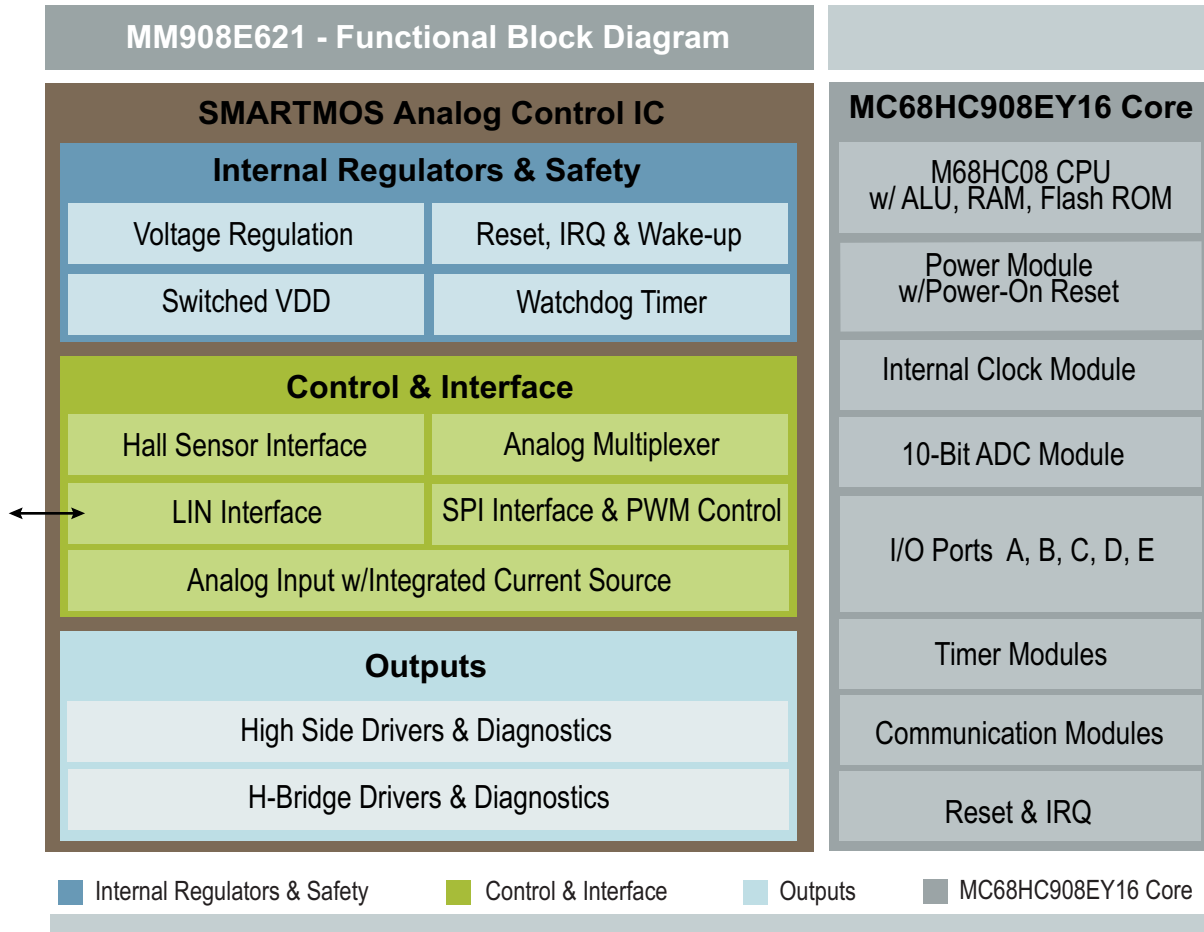

SMARTMOS ANALOG CONTROL IC

INTERNAL REGULATORS & SAFETY:

VOLTAGE REGULATION

The voltage regulator circuitry provides the regulated voltage for the Analog IC as well as the VDD/VSS rails for the core IC. The on-chip regulator consists of two elements, the main regulator, and the low voltage reset circuit. The V_{DD} regulator accepts an unregulated input supply, and provides a regulated V_{DD} supply to all digital sections of the device. The output of the regulator is also connected to the VDD pin, to provide the 5.0 V to the microcontroller.

SWITCHED VDD

This function provides a switchable +5.0 V V_{DD} rail for an external load.

WATCHDOG TIMER

The watchdog timer module generates a reset, in case of a watchdog timeout or wrong watchdog timer reset. A

watchdog reset event will reset all registers in the SPI, excluding the RSR.

RESET, IRQ & WAKE-UP

There are several functions on the Analog IC that can generate a reset or wake-up signal to the core IC. There is a pin that is used to detect an external wake-up event. The Reset signal has many possible sources in the Analog IC circuitry. The IRQ function on the Analog IC, will notify the core IC of pending system critical conditions.

CONTROL & INTERFACE:

HALL SENSOR INTERFACE

This interface can be configured to support an input pin as a general purpose input, or as a hall-effect sensor input, to be able to read 3-pin / 2-pin hall sensors or switches.

SPI INTERFACE & PWM CONTROL

The SPI and PWM interfaces are mastered by the core IC (CPU), and are used to control the output functions of the Analog IC, as well as to report status and failure information of the Analog IC.

LIN INTERFACE

The LIN interface function supports the single wire bus transmit and receive capabilities. It is suited for automotive bus systems and is based on the LIN bus/physical layer specification. The LIN driver is a low side MOSFET with slope control, internal current limitation, and thermal shutdown.

ANALOG MULTIPLEXER

To be able to have different sources for the MCU with one single signal, an analog multiplexer is integrated in the analog IC. This multiplexer has eleven different sources on the Analog IC, which can be selected with the SS[3:0] bits (through SPI communication) in the A0MUCTL register.

ANALOG INPUT W/INTEGRATED CURRENT SOURCE

The terminal A0 provides a switchable current source, to allow the reading of switches, NTC, etc., without the need for an additional supply line for the sensor (single wire). There are four different selectable current source values.

OUTPUTS:

HIGH SIDE DRIVERS & DIAGNOSTICS

The HS outputs are low RDS(ON) high side switches. Each HS switch is protected against over-temperature and over-current. The output is capable of limiting the inrush current with an automatic PWM, or feature a real PWM capability using the PWM input.

H-BRIDGE DRIVERS & DIAGNOSTICS

The device includes power MOSFETs configured as four half-bridge driver outputs. These outputs are short-circuit and over-temperature protected. Over-current protection is done on both high side and low side MOSFETs.

MM68HC908EY16 CORE IC

M68HC08 CPU W/ALU, RAM, FLASH ROM

This possesses the functionality of the CPU08 architecture, along with 512 bytes of RAM and 15,872 bytes of FLASH memory, with in-circuit programming.

POWER MODULE W/POWER-ON-RESET

This block of circuitry manages the power supplied to the core IC, as well as providing POR, LVI, Watchdog timer, and MCU supervision circuitry (COP).

INTERNAL CLOCK MODULE

This module provides the clocks needed by the core IC functions, without the need for external components. Software selectable bus frequencies are available. It also provides a clock monitor function.

10-BIT ADC MODULE

This module provides an 8-channel, 10-bit successive approximation analog-to-digital converter (ADC).

I/O PORTS A, B, C, D, E

There are many I/O pins that are controlled by the CPU through the several I/O ports of the core IC.

TIMER MODULES

There are two 16-bit, 2 channel timer interface modules with selectable input capture, output compare, and PWM capabilities, for each channel.

COMMUNICATION MODULES

There are several communication functions supported by the core IC, including an enhanced serial communication interface module (ESCI) for the LIN communication, and an SPI module for inter-IC communication.

RESET & IRQ

There are interrupt and reset connections between the Analog IC and the core IC, for concise control and error/exception management.

up sources can be selected (maskable), which is not possible in Sleep mode.

[Figure 12](#) show the procedure to enter the Stop mode and how the system is waking up.

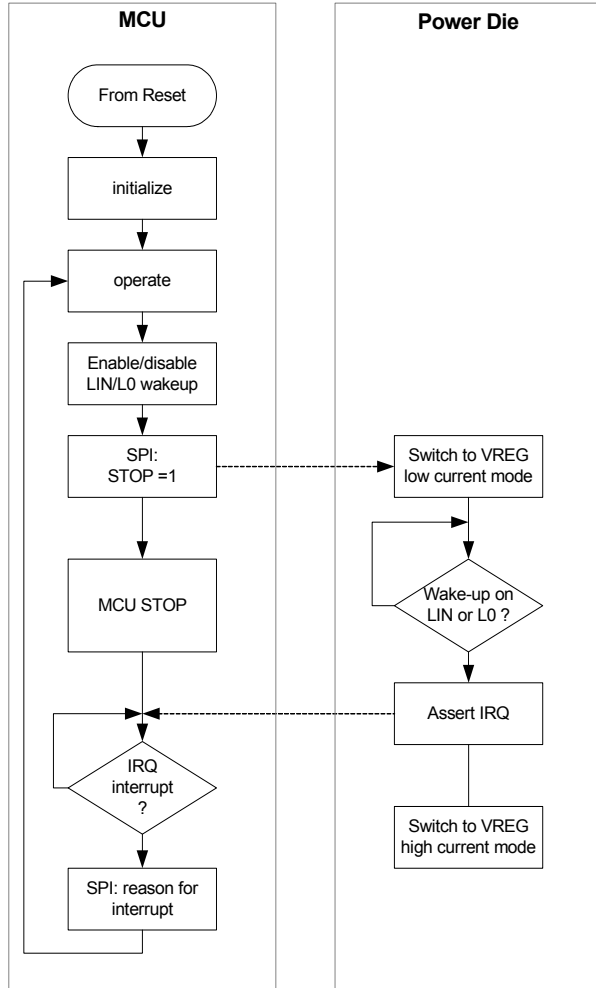

Figure 12. STOP Mode Wake-up Procedure

Sleep Mode

In Sleep mode, the voltage regulator is turned off and the MCU is not supplied ($V_{DD} = 0\text{ V}$), also the $\overline{\text{RST_A}}$ pin is pulled low.

To enter the Sleep mode, the Sleep bit in the System Control Register has to be set.

Wake-up from this mode is possible by LIN bus activity or the wake-up input L0, and is not maskable. The wake-up

behaves like a power on reset. The wake-up / reset source can be evaluated by the LOWF and/or LINWF bits in the Reset Status Register.

Sleep mode has a lower current consumption than Stop mode, but requires a longer time to wake-up. The wake-up sources can not be selected (not maskable).

[Figure 13](#) show the procedure to enter the Sleep mode and how a wake-up is performed.

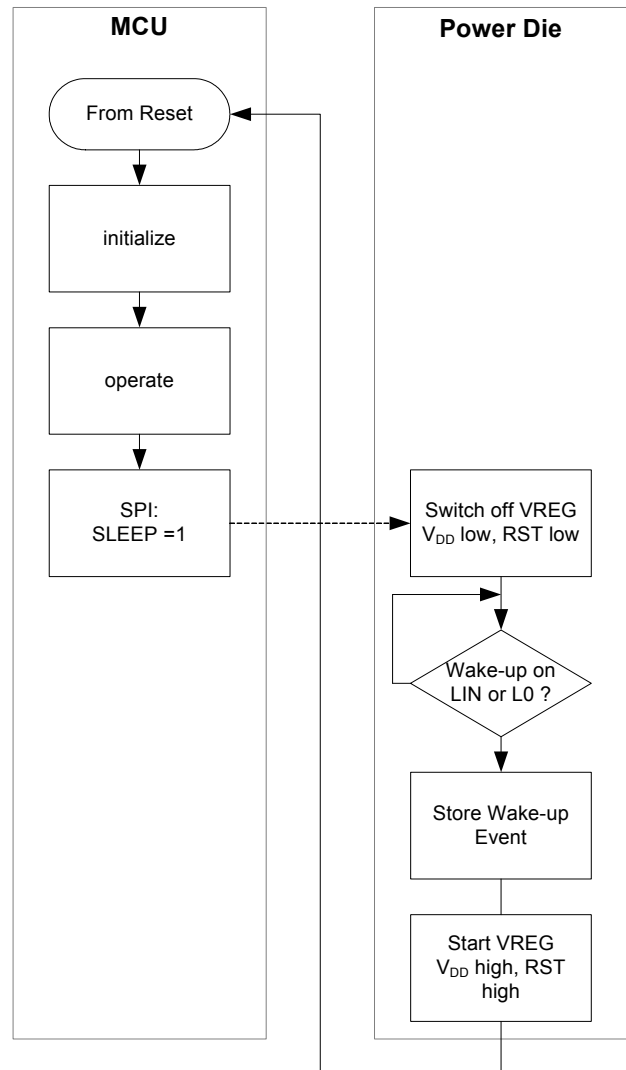

Figure 13. SLEEP Mode Wake-up Procedure

[Table 6](#) summarized the Operating modes.

Table 6. Operating Modes Overview

Device Mode	Voltage Regulator	Wake-up Capabilities	RST_A Output	MCU monitoring/ Watchdog Function	Power Stages	LIN Interface
Reset	V _{DD} ON	N/A	LOW	Disabled	Disabled	Disabled
Normal Request	V _{DD} ON	N/A	HIGH	t _{NORMREQ} (80 ms typical) timeout to set PSON bit in System Control Register	Disabled	Disabled
Normal (Run)	V _{DD} ON	N/A	HIGH	Window Watchdog active if enabled	Enabled	Enabled
Stop	V _{DD} ON with limited current capability	LIN wake-up, L0 state change (SPI PSON=1) ⁽³⁵⁾	HIGH	Disabled	Disabled	Recessive state with wake-up capability
Sleep	V _{DD} OFF	LIN wake-up L0 state change	LOW	Disabled	Disabled	Recessive state with wake-up capability

Notes

35. The SPI is still active in Stop mode. However, due to the limited current capability of the voltage regulator in Stop mode, the PSON bit has to be set before the increased current caused from a running MCU causes an LVR.

OPERATING MODES OF THE MCU

For a detailed description of the operating modes of the MCU, refer to the MC68HC908EY16 datasheet.

INTERRUPTS

The 908E621 has seven different interrupt sources. An interrupt pulse on the IRQ_A pin is generated to report an event or fault to the MCU. All interrupts are maskable and can be enabled/disabled via the SPI (Interrupt Mask Register). After reset, all interrupts are automatically disabled.

Low Voltage Interrupt

Low voltage interrupt (LVI) is related to external supply voltage VSUP. If this voltage falls below the LVI threshold, it will set the LVIF bit in the Interrupt Flag Register. If the low voltage interrupt is enabled (LVIE = 1), an interrupt will be initiated.

During Sleep and Stop mode, the low voltage interrupt circuitry is disabled.

High Voltage Interrupt

The High voltage Interrupt (HVI) is related to the external supply voltage VSUP. If this voltage rises above the HVI threshold, it will set the HVIF bit in the Interrupt Flag Register. If the High voltage Interrupt is enabled (HVIE = 1), an interrupt will be initiated.

During Stop and Sleep mode, the HVI circuitry is disabled.

High Temperature Interrupt

The high temperature interrupt (HTI) is generated by the on chip temperature sensors. If the chip temperature is above the HTI threshold, the HTIF bit in the Interrupt Flag Register

will be set. If the high temperature interrupt is enabled (HTIE = 1), an interrupt will be initiated.

During Stop and Sleep mode, the HTI circuitry is disabled.

LIN Interrupt

The LIN Interrupt is related to the Stop mode. If the LIN interrupt is enabled (LINIE = 1) in Stop mode, an interrupt is asserted if a rising edge is detected, and the bus was dominant longer than T_{PROPWL}. After the wake-up / interrupt, the LINIF indicates the reason for the wake-up / interrupt.

Power Stage Fail Interrupt

The power stage fail flag indicates an error condition on any of the power stages (see [Figure 14](#), page 27). If the power stage fail interrupt is enabled (PSFIE = 1), an interrupt will be initiated if:

During Stop and Sleep mode, the PSFI circuitry is disabled.

H0 Input Interrupt

The H0 interrupt flag H0IF is set in run mode by a state change of the H0F flag (rising or falling edge on the enabled input). The interrupt function is available if the input is selected as General Purpose, or as a 2-pin Hall sensor input. The interrupt is maskable with the H0IE bit in the Interrupt Mask Register.

During Stop and Sleep mode, the H0I circuitry is disabled.

L0 input Interrupt

The L0 interrupt flag L0IF is set in run mode by a state change of the L0F flag (rising or falling edge). The interrupt is maskable with the L0IE bit in the interrupt mask register.

INTERRUPT FLAG REGISTER (IFR)

Register Name and Address: IFR - \$0A

	Bit7	6	5	4	3	2	1	Bit0
Read	L0IF	H0IF	LINIF	0	HTIF	LVIF	HVIF	PSFIF
Write	L0IF	H0IF	LINIF	0	HTIF	LVIF	HVIF	
Reset	0	0	0	0	0	0	0	0

L0IF - L0 Input Flag Bit

This read/write flag is set on a falling or rising edge at the L0 input. Clear L0IF by writing a logic [1] to L0IF. Reset clears the L0IF bit. Writing a logic [0] to L0IF has no effect.

- 1 = rising or falling edge on L0 input detected
- 0 = no state change on L0 input detected

H0IF - H0 Input Flag Bit

This read/write flag is set on a falling or rising edge at the H0 input. Clear H0IF by writing a logic [1] to H0IF. Reset clears the H0IF bit. Writing a logic [0] to H0IF has no effect.

- 1 = state change on the hall-flags detected
- 0 = no state change on the hall-flags detected

LINIF - LIN Flag Bit

This read/write flag is set if a rising edge is detected and the bus was dominant longer than TpropWL. Clear LINIF by writing a logic [1] to LINIF. Reset clears the LINIF bit. Writing a logic [0] to LINIF has no effect.

- 1 = LIN bus interrupt has occurred
- 0 = not LIN bus interrupt occurred since last clear

HTIF - High Temperature Flag Bit

This read/write flag is set on high temperature condition. Clear HTIF by writing a logic [1] to HTIF. If high temperature condition is still present while writing a logical one to HTIF, the writing has no effect. Therefore, a high temperature interrupt cannot be lost due to inadvertent clearing of HTIF. Reset clears the HTIF bit. Writing a logic [0] to HTIF has no effect.

- 1 = high temperature condition has occurred
- 0 = high temperature condition has not occurred

LVIF - Low Voltage Flag Bit

This read/write flag is set on low voltage condition. Clear LVIF by writing a logic [1] to LVIF. If the low voltage condition

is still present while writing a logical one to LVIF, the writing has no effect. Therefore, a low voltage interrupt cannot be lost due to inadvertent clearing of LVIF. Reset clears the LVIF bit. Writing a logic [0] to LVIF has no effect.

- 1 = low voltage condition has occurred
- 0 = low voltage condition has not occurred

HVIF - High Voltage Flag Bit

This read/write flag is set on a high voltage condition. Clear HVIF by writing a logic [1] to HVIF. If the high voltage condition is still present while writing a logical one to HVIF, the writing has no effect. Therefore, a high voltage interrupt cannot be lost due to inadvertent clearing of HVIF. Reset clears the HVIF bit. Writing a logic [0] to HVIF has no effect.

- 1 = high voltage condition has occurred
- 0 = high voltage condition has not occurred

PSFIF - Power Stage Fail Bit

This read-only flag is set on a fail condition on one of the power outputs (HBx, HSx, HVDD, H0). Reset clears the PSFIF bit. Clear this flag by writing a logic [1] to the appropriate fail flag.

- 1 = power stage fail condition has occurred
- 0 = power stage fail condition has not occurred

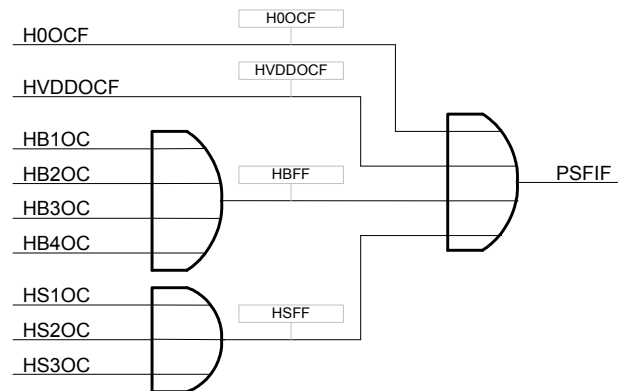

Figure 14. Principal Implementation of the PSFIF

INTERRUPT MASK REGISTER (IMR)

Register Name and Address: IMR - \$09

	Bit7	6	5	4	3	2	1	Bit0
Read	L0IE	H0IE	LINIE	HTRD	HTIE	LVIE	HVIE	PSFIE
Write	L0IE	H0IE	LINIE	HTRD	HTIE	LVIE	HVIE	
Reset	0	0	0	0	0	0	0	0

L0IE - L0 Input Interrupt Enable Bit

This read/write bit enables CPU interrupts by the L0 flag, L0IF. Reset clears the L0IE bit.

- 1 = interrupt requests from L0IF flag enabled
- 0 = interrupt requests from L0IF flag disabled

H0IE - H0 Input Interrupt Enable Bit

This read/write bit enables CPU interrupts by the Hallport flag, H0IF. Reset clears the H0IE bit.

- 1 = interrupt requests from H0IF flag enabled
- 0 = interrupt requests from H0IF flag disabled

LINIE - LIN line Interrupt Enable Bit

This read/write bit enables CPU interrupts by the LIN flag, LINIF. Reset clears the LINIE bit.

- 1 = interrupt requests from LINIF flag enabled
- 0 = interrupt requests from LINIF flag disabled

HTRD - High Temperature Reset Disable Bit

This read/write bit disables the high temperature reset function. Reset clears the HTRD bit.

- 1 = high temperature reset is disabled
- 0 = high temperature reset is enabled

Note: Disabling of the high temperature reset can lead to a destruction of the part in cases of high temperature. This bit was foreseen for test purposes only!

HTIE - High Temperature Interrupt Enable Bit

This read/write bit enables CPU interrupts by the high temperature flag, HTIF. Reset clears the HTIE bit.

- 1 = interrupt requests from HTIF flag enabled
- 0 = interrupt requests from HTIF flag disabled

LVIE - Low Voltage Interrupt Enable Bit

This read/write bit enables CPU interrupts by the low voltage flag, LVIF. Reset clears the LVIE bit.

- 1 = interrupt requests from LVIF flag enabled
- 0 = interrupt requests from LVIF flag disabled

HVIE - High Voltage Interrupt Enable Bit

This read/write bit enables CPU interrupts by the high voltage flag, HVIF. Reset clears the HVIE bit.

- 1 = interrupt requests from HVIF flag enabled
- 0 = interrupt requests from HVIF flag disabled

PSFIE - Power Stage Fail Interrupt Enable Bit

This read/write bit enables CPU interrupts by power stage fail flag, PSFIF. Reset clears the PSFIE bit.

- 1 = interrupt requests from PSFIF flag enabled
- 0 = interrupt requests from PSFIF flag disabled

RESETS

The 908E621 has four internal and one external reset source.

Each internal reset event will cause a reset pin low for t_{RST} (1.25 ms typical), after the reset event is gone.

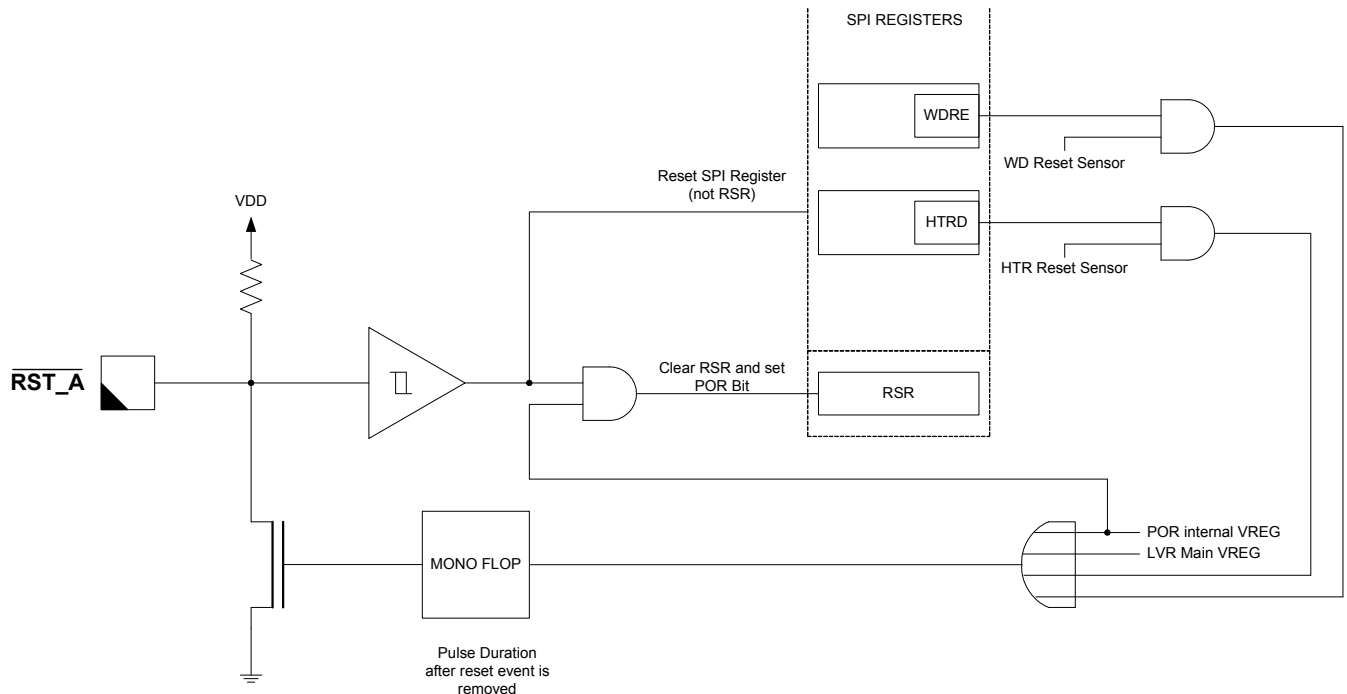

Figure 15. Internal Reset Routing

RESET SOURCE

High Temperature Reset

The device is protected against high temperature. When the chip temperature exceeds a certain temperature, a reset (HTR) is generated. The reset is flagged by the HTR bit in the Interrupt Flag Register. A HTR event will reset all registers in the SPI excluding the RSR.

The HTR can be disabled by bit HTRD in the Interrupt Mask register.

Note: Disabling the high temperature reset can lead to destruction of the part in cases of high temperature. This bit was foreseen for test purposes only!

Watchdog Reset

The watchdog module generates a reset, because of a watchdog timeout or wrong watchdog timer reset. Reset is flagged by the WDR bit in the Reset Status Register. A watchdog reset event will reset all registers in the SPI excluding the RSR.

Main VREG Low Voltage Reset

The LVR is related to the Main VDD. If the voltage falls below a certain threshold, it will pull down the $\overline{\text{RST_A}}$ pin. Reset is flagged by the LVR bit in the Reset Status Register. An LVR event will reset all register in the SPI excluding the RSR.

Power On Reset

The POR is related to the internal 5.0 V supply. If the device detects a power on, the POR bit in the Reset Status Register (RSR) is set. A power on reset will reset all register in the SPI including the RSR and set the POR bit.

The Power On Reset circuitry will force the $\overline{\text{RST_A}}$ pin low for $t_{\overline{\text{RST}}}$ after the V_{DD} has reached its nominal value (above LVR Threshold). Also see [Figure 10](#), page 18).

Reset Pin / External Reset

An external reset can be applied by pulling down the $\overline{\text{RST_A}}$ pin. The reset event is flagged by the PINR bit in the reset status register.

Reset Status Register

This register contains five flags that shows the source of the last reset. A power-on-reset sets the POR bit and clears all other bits in the Reset Status Register. All bits can be cleared by writing a one to the corresponding bit. Uncleared bits remain set as long as they are not cleared by a power-on-reset or by software.

In addition, the register includes two flags which will indicate the source of a wake-up from Sleep mode: Either LIN bus activity, or an event on the L0 wake-up input pin.

Register Name and Address: RSR - \$0D

	Bit7	6	5	4	3	2	1	Bit0
Read	POR	PINR	WDR	HTR	LVR	0	LINWF	LOWF
Write								
POR	1	0	0	0	0	0	0	0

POR— Power On Reset bit

This read/write bit is set after power on. Bit is cleared by writing a logic “1” to this location.

- 1 = Reset due to power on
- 0 = no power on reset

PINR— Reset Forced from External Reset Pin Bit

This read/write bit is set after a reset was forced on the external reset $\overline{\text{RST_A}}$ pin. The bit is cleared by writing an logic “1” to this location.

- 1 = reset source is external reset pin
- 0 = no external reset

WDR— Watch Dog Reset Bit

This read/write flag is set due to a watchdog timeout or wrong watchdog timer reset. Clear WDR by writing a logic “1” to WDR.

- 1 = reset source is watchdog
- 0 = no watchdog reset

HTR— High Temperature Reset Bit

This read/write bit is set if the chip temperature exceeds a certain value. The bit is cleared by writing a logic “1” to this location.

- 1 = reset due to high temperature condition
- 0 = no high temperature reset

LVR— Low Voltage Reset Bit

This read/write bit is set if the external V_{DD} voltage coming from the main voltage regulator falls below a certain value. The bit is cleared by writing a logic “1” to this location.

- 1 = reset due to low voltage condition
- 0 = no low voltage reset

LINWF— LIN Wake-up Flag

This read/write bit is set if a bus activity was the case of an wake-up. The bit is cleared by writing a logic “1” to this location.

- 1 = Wake-up due to bus activity
- 0 = no wake-up due to bus activity

LOWF— L0 Wake-up Flag

This read/write bit is set if a event on the L0 pin caused an wake-up. The bit is cleared by writing a logic “1” to this location.

1 = Wake-up due to L0 pin
 0 = no Wake-up due to L0 pin

ANALOG DIE INPUTS/OUTPUTS

LIN PHYSICAL LAYER

The LIN bus pin provides a physical layer for single wire communication in automotive applications. The LIN physical layer is designed to meet the LIN physical layer specification.

The LIN driver is a low side MOSFET with internal current limitation and thermal shutdown. An internal pull-up resistor with a serial diode structure is integrated, so no external pull-up components are required for the application in a slave node. The fall time from dominant to recessive and the rise time from recessive to dominant is controlled. The symmetry between both slew rate controls is guaranteed.

The slew rate can be selected for optimized operation at 10 and 20 kBit/s as well as high baud rates for test and programming. The slew rate can be adapted with 2 bits SRS[1:0] in the System Control Register. The initial slew rate is optimized for 20 kBit/s.

The LIN pin offers high susceptibility immunity level from external disturbance, guaranteeing communication during external disturbance.

The LIN transmitter circuitry is enabled by setting the PSON bit in the System Control Register (SYSCTL).

If the transmitter works in the current limitation region, the LINCL bit in the System Status Register (SYSSTAT) is set and the LIN transceiver is disabled after a certain time.

For improved performance and safe behavior, in case of LIN bus short to Ground or LIN bus leakage during low power mode, the internal pull-up resistor on the LIN pin is disconnected from VSUP and a small current source keeps the LIN bus at recessive level. In case of a LIN bus short to GND, this feature will reduce the current consumption in STOP and SLEEP modes.

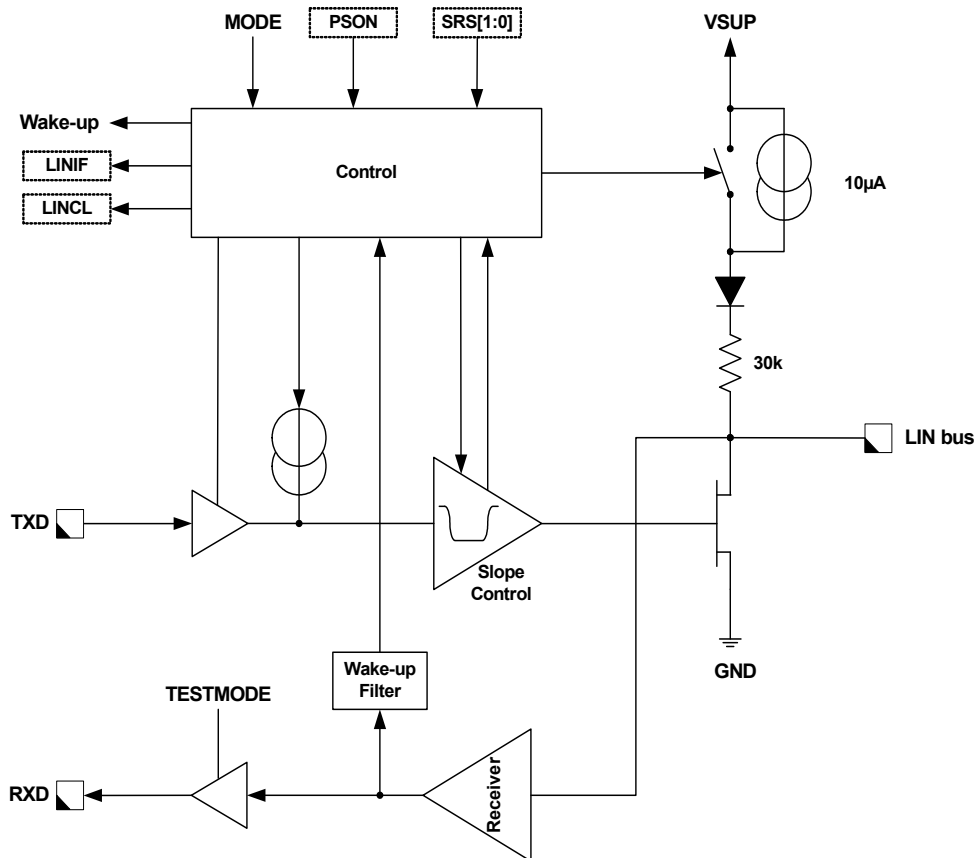

Figure 16. LIN Interface

TXD Pin

The TXD pin is the MCU interface to control the state of the LIN transmitter (see [Figure 2](#)). When TXD is LOW, the LIN

pin is low (dominant state). When TXD is HIGH, the LIN output MOSFET is turned off (recessive state). The TXD pin has an internal pull-up current source to set the LIN bus to a recessive state in the event, for instance, if the

microcontroller could not control it during system power-up or power-down.

RXD Pin

The RXD transceiver pin is the MCU interface, which reports the state of the LIN bus voltage. LIN HIGH (recessive state) is reported by a high level on RXD, LIN LOW (dominant state) by a low level on RXD.

STOP Mode and Wake-up Feature

During STOP mode operation the transmitter of the physical layer is disabled and the internal pull-up resistor is disconnected from VSUP and a small current source keeps the LIN pin in recessive state. The receiver is still active and able to detect wake-up events on the LIN bus line.

If the LIN interrupt is enabled (LINIE bit in the Interrupt Mask register is set), a dominant level longer than T_{PROPWL} followed by an rising edge will set the LINIF flag and generate an interrupt which causes a system wake-up (see [Figure 8](#), page 17)

SLEEP Mode and Wake-up Feature

During SLEEP mode operation the transmitter of the physical layer is disabled, the internal pull-up resistor is disconnected from VSUP, and a small current source keeps the LIN pin in the recessive state. The receiver is still active to be able to detect wake-up events on the LIN bus line.

A dominant level longer than T_{PROPWL} followed by an rising edge will generate a system wake-up (reset) and set the LINWF flag in the Reset Status register (RSR). Also see [Figure 9](#), page 17).

A0 INPUT AND ANALOG MULTIPLEXER

A0 - Analog Input

Input A0 is an analog input used for reading switches, or as analog inputs for potentiometers, NTC, etc.

A0 is internally connected to the analog multiplexer. This pin offers a switchable current source. To read the Analog Input, the pin has to be selected with the SS[3:0] bits in the A0MUCTL register.

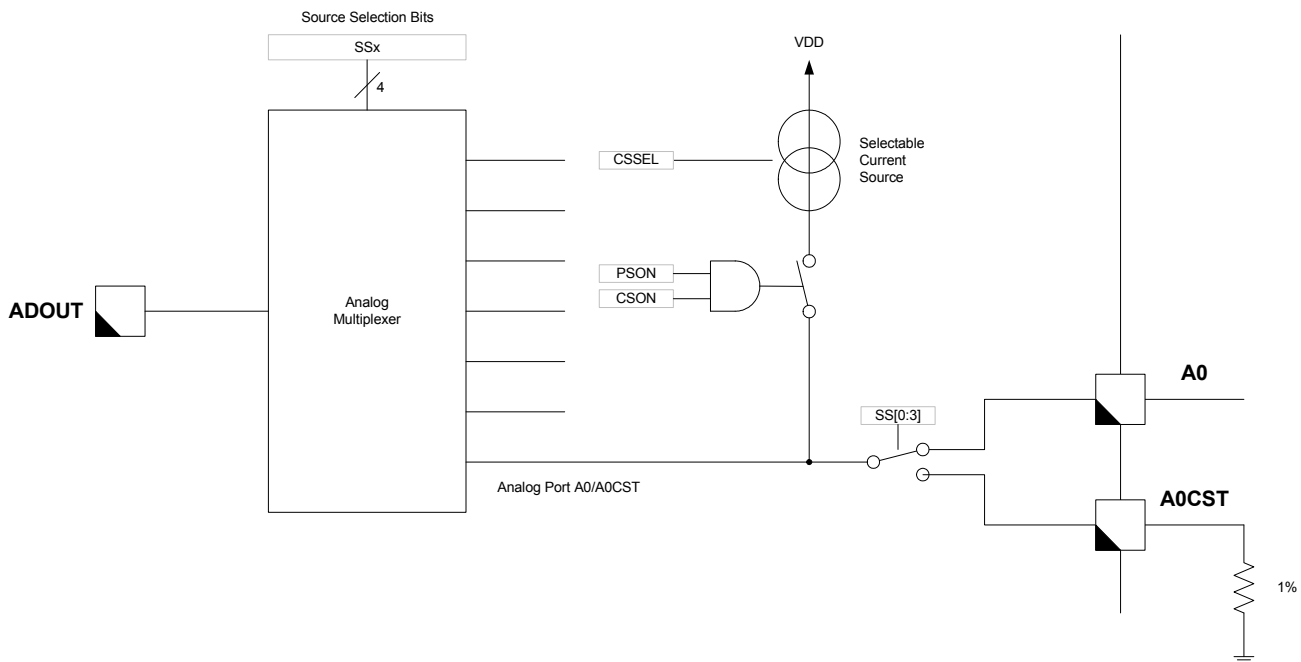

Figure 17. Analog Input and Multiplexer

A0 Current Source

The pin A0 provides a switchable current source, to be able to read in switches, NTC, etc., without the need of an additional supply line for the sensor. The overall enable of this feature is done by setting the PSON bit in the System Control register. In addition, the pin has to be selected with

the SS[3:0] bits. The current source can be enabled with the CSON Bit and adjusted with the bits CSSEL[1:0].

With the CSSEL[1:0] bit's, four different current values can be selected (40, 120, 320, and 800 μ A). This function is halted during STOP and SLEEP mode operations.

The current source is derived from the V_{DD} voltage, and is constant up to an output voltage of ~ 4.75 V.

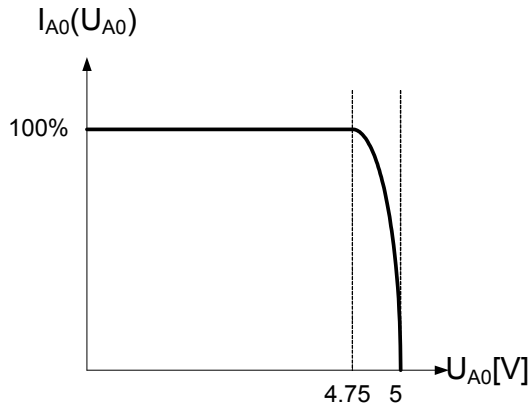

To calibrate the current sources, an extra pin (A0CST) is envisioned. On this pin, an accurate resistor can be connected. Switching the current sources to this resistor, allows the user to measure the current and use the measured value for calculating the current on A0.

Analog Multiplexer / ADOUT pin

The ADOUT pin is the analog output interface to the Analog-to-digital converter of the MCU. To be able to have different sources for the MCU with one single signal, an analog multiplexer is integrated in the analog die. This multiplexer has eleven different sources, which can be selected with the SS[3:0] bits in the A0MUCTL register.

Half-bridge (HB1:HB4) Current Recopy

The multiplexer is connected to the four current sense circuits on the low side FET of the half bridges. This sense circuit offers a voltage proportional to the current through the MOSFET. The resolution is depending on the CSA bit in the A0 and Multiplexer control register (A0MUCTL).

High Side (HS1:HS3) Current Recopy

The multiplexer is connected to the three high side switches. This sense circuit offers a voltage proportional to the current through the transistor.

Analog Input A0 and A0CST

A0 and A0CST are directly connected to the analog multiplexer. It offers the possibility to read analog values from the periphery.

Temperature Sensor

The analog die includes an on chip temperature sensor. This sensor offers a voltage which is proportional to the actual mean chip junction temperature.

VSUP Prescaler

The VSUP prescaler offers a possibility to measure the external supply voltage. The output of this voltage is VSUP / RATIOVSUP.

A0 and Multiplexer Control Register (A0MUCTL)

Register Name and Address: A0MUCTL - \$08

	Bit7	6	5	4	3	2	1	Bit0
Read	CSON	CSSEL ₁	CSSEL ₀	CSA	SS3	SS2	SS1	SS0
Write								
Reset	0	0	0	0	0	0	0	0

CSON — Current Source on/off

This read/write bit enables the current source for the A0 or A0CST inputs. Reset clears CSON bit.

- 1 = Current Source enabled
- 0 = Current Source disabled

CSSEL[1:0] — Current Source Select Bits

These read/write bits select the current source values for A0 or A0CST input. Reset clears CSSEL[1:0] bits.

Table 7. A0 Current Source Level Selection Bits

CSSEL1	CSSEL0	Current Source Enable (typ.)
0	0	40 μ A
0	1	120 μ A
1	0	320 μ A
1	1	800 μ A

CSA — H-bridges Current Sense Amplification Select Bit

This read/write bit selects the current sense amplification of the H-Bridges HB1:HB4 current recopy. Reset clears the CSA bit.

- 1 = low current sense amplification
- 0 = high current sense amplification

SS[3:0] — Analog Source Input Select Bits

These read/write bits selects the analog input source for the ADOUT pin. Reset clears the SS[3:0] bits Analog Multiplexer Configuration Bits.

SS3	SS2	SS1	SS0	Channel
0	0	0	0	current recopy HB1
0	0	0	1	current recopy HB2
0	0	1	0	current recopy HB3
0	0	1	1	current recopy HB4
0	1	0	0	current recopy HS1
0	1	0	1	current recopy HS2
0	1	1	0	current recopy HS3
0	1	1	1	not used

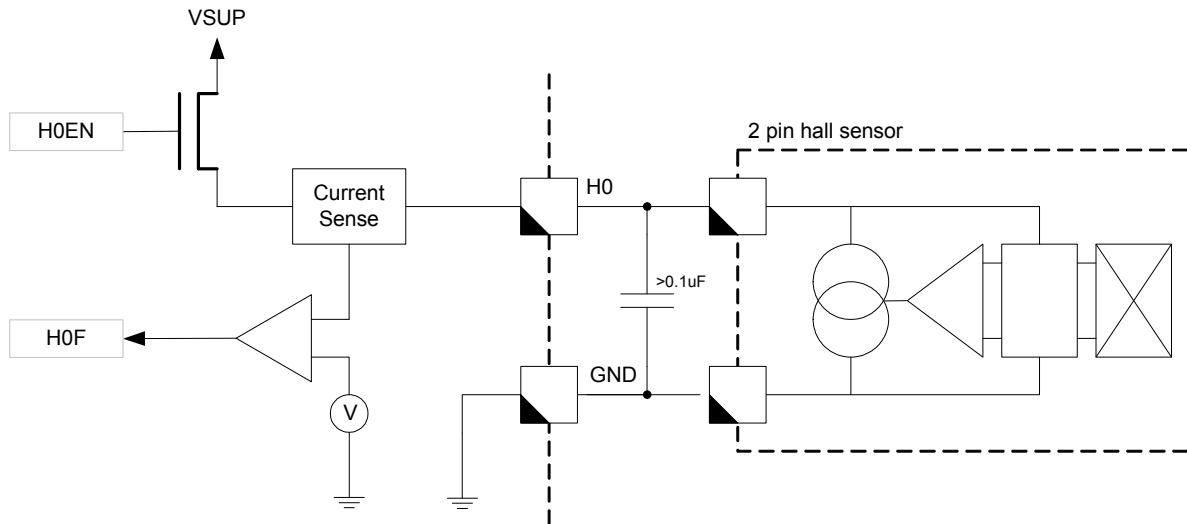

Figure 19. H0 Used as 2-pin Hall-sensor Input

General Purpose Input

H0 is selected as a general purpose input, if the H0MS bit in the H0/L0 Status and Control Register (HLSCCTL) is cleared. In this mode, the input is usable as a standard 5.0 V

input. The H0 input has a selectable internal pull-up resistor. The pull-up can be switched off with the H0PD bit in the H0/L0 Status and Control Register (HLSCCTL). After reset, the internal pull-up is enabled.

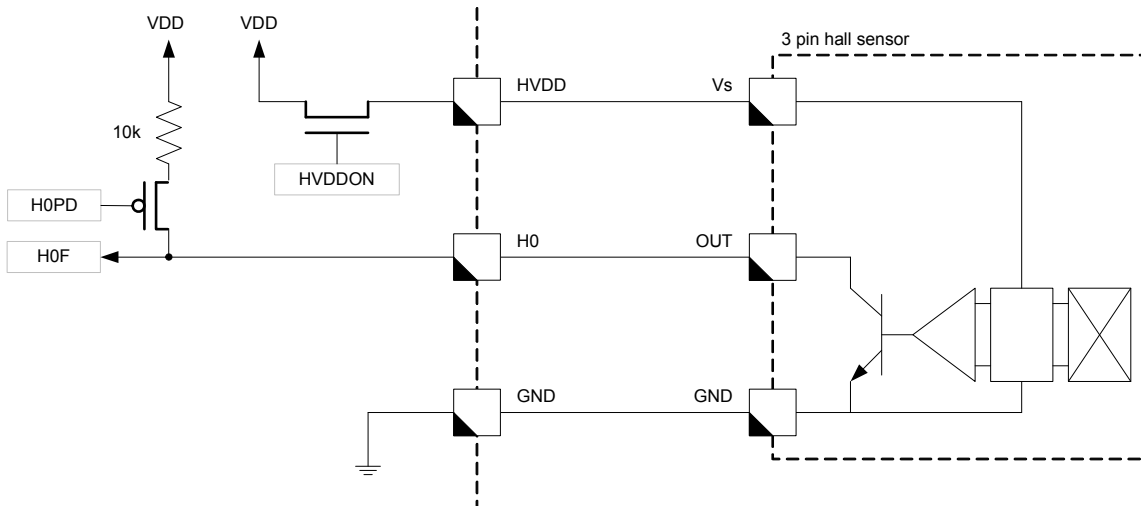

Figure 20. H0 Used as 3 Pin Hall-effect Sensor Input

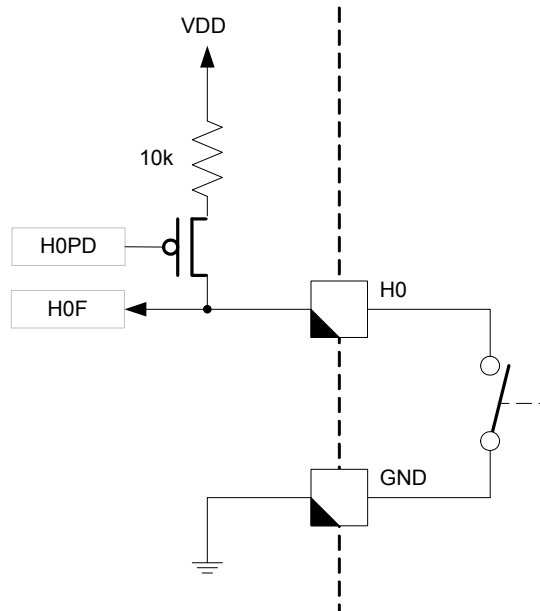

Figure 21. H0 Used to Read in Standard Switches

H0 Interrupt

The interrupt functionality on this pin is only available in RUN mode. The H0 interrupt flag H0IF is set in run mode by a state change of the H0 flag (rising or falling edge on the enabled input). The interrupt function is available if the input is selected as General Purpose or as 2-pin Hall-sensor input. The interrupt can be masked with the H0IE bit in the interrupt mask register.

Wake-up input L0

The device provides one wake-up capable input for reading VSUP or VDD related signals.

RUN Mode

The actual input state is reflected in the L0F bit of the H0/L0 Status and Control register (HLSCTL).

The L0 pin offers an interrupt capability on the rising and falling edge. The interrupt can be enabled with the L0IE bit in the Interrupt Mask register.

STOP/SLEEP Mode

During STOP and SLEEP mode, the pin can be used to wake-up the device.

Before entering the STOP or SLEEP mode, the actual state of the input is stored. If the state is changing during in the STOP or SLEEP mode, a wake-up is initiated.

H0 / L0 Status and Control Register (HLSCTL)

Register Name and Address: **HLSCTL - \$07**

	Bit7	6	5	4	3	2	1	Bit0
Read	L0F	0	0	H0OCF	H0F	H0EN	H0PD	H0MS
Write								
Reset	0	0	0	0	0	0	0	0

L0F — L0 Flag Bit

This read only flag reflects the state of the L0 input

- 1 = L0 input high
- 0 = L0 input low

H0OCF — H0 Over-current Flag Bit

This read/write flag is set at over-current condition on H0 during 2-pin hall-sensor mode. Clear H0OCF by writing a logic [1] to H0OCF. Reset clears the H0OCF bit.

- 1 = over-current condition on H0 pin has occurred
- 0 = no over-current condition on H0 pin has occurred

H0F — H0 Flag Bit

This read only flag reflects the state of the H0 input

- 1 = Hall-port sensed high / current below threshold detected
- 0 = Hall-port sensed low / current above threshold detected

H0EN — H0 Input 2-pin Hall-effect sensor Enable Bit

This read/write bit enables the 2-pin hall-effect sensor sense circuitry. Reset clears H0EN bit.

- 1 = Hall-port H0 is switched on and sensed
- 0 = Hall-port H0 disabled

H0PD — Hall-port Pull-up Disable Bit

This read/write bit disables the H0 Pull-up resistor. Reset clears H0PD bit.

- 1 = Hall-port pull-up resistor on H0 disabled
- 0 = Hall-port pull-up resistor on H0 enabled

H0MS — H0 Mode Select

These read/write bits select the mode of the H0 input. Reset clears H0MS bit.

- 1 = H0 is 2-pin hall-sensor input
- 0 = H0 is general purpose input

Half-bridge Outputs

Outputs HB1:HB4 provide four low-resistive half-bridge output stages. The half-bridges can be used in H-bridge, high side or low side configurations.

Reset clears all bits in the H-bridge Output Register (HBOUT) owing to the fact that all half-bridge outputs are switched off.

HB1:HB4 output features

- Short-circuit (over-current) protection on high side and low side MOSFETs
- Current recopy feature (low side MOSFET)
- Over-temperature protection
- Over-voltage and under-voltage protection
- Active clamp on low side MOSFET

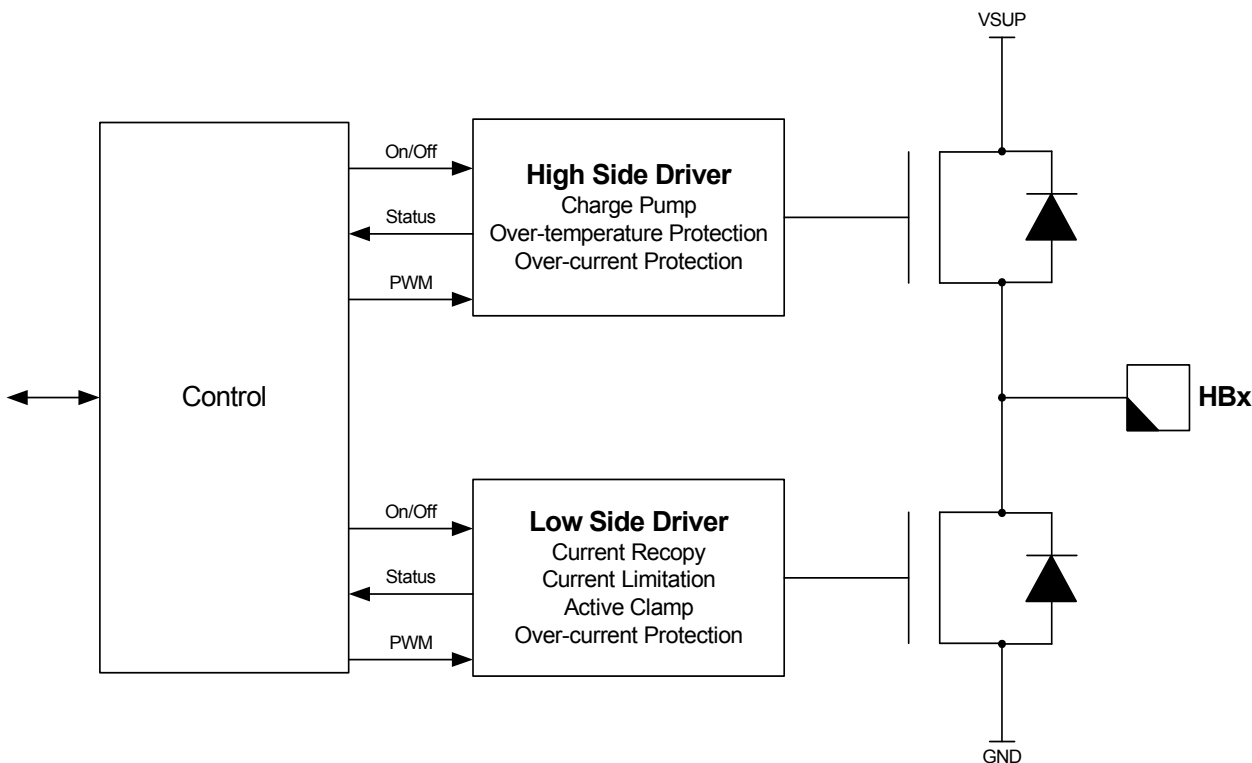

Figure 22. Half-bridge Push-Pull Output Driver

Half-bridge Control

Each output MOSFET can be controlled individually. The general enable of the circuitry is done by setting PSON in the System Control Register (SYSCTL). The HBx_L and HBx_H bits form one half-bridge. It is not possible to switch on both MOSFETs in one half-bridge at the same time. If both bits are set, the high side MOSFET is in PWM mode.

To avoid both MOSFETs (high side and low side) of one half-bridge being on at the same time, a break-before-make circuit exists. Switching the high side MOSFET on is inhibited as long as the potential between gate and V_{SS} is not below a certain threshold. Switching the low side MOSFET on is blocked as long as the potential between gate and source of the high side MOSFET did not fall below a certain threshold.

HALF-BRIDGE OUTPUT REGISTER (HBOUT)

Register Name and Address: HBOUT - \$01

	Bit7	6	5	4	3	2	1	Bit0
Read	HB4_ H	HB4_ L	HB3_ H	HB3_ L	HB2_ H	HB2_ L	HB1_ H	HB1_ L
Write	H	L	H	L	H	L	H	L
Reset	0	0	0	0	0	0	0	0

HBx_H, HBx_L — Half-bridge Output Switches

These read/write bits select the output of each half-bridge output according to Table . Reset clears all HBx_H, HBx_L bits.

Table 8. Half-bridge Configuration

HBx_H	HBx_L	Mode
0	0	Low side and high side MOSFET off
0	1	High side MOSFET off, low side MOSFET on
1	0	High side MOSFET on, low side MOSFET off
1	1	High side MOSFET in PWM mode

Half-bridge PWM mode

The PWM mode is selected by setting both HBxL and HBxH of one half-bridge to “1”. In this mode, the high side MOSFET is controlled by the incoming PWM signal on the PWM pin (see [Figure 2](#), page 2).

If the incoming signal is high, the high side MOSFET is switched on.

If the incoming signal is low, the high side MOSFET is switched off.

With the current recirculation mode control bit CRM in the Half-bridge Status and Control Register (HBSCTL), the recirculation behavior in PWM mode can be controlled. If CRM is set, the corresponding low side MOSFET is switched on, if the PWM controlled high side MOSFET is off.

Half-bridge Current Recopy

Each low side MOSFET has an additional sense output to allow a current recopy feature. These sense sources are internally amplified and switched to the Analog Multiplexer.

The factor for the Current Sense amplification can be selected via the CSA bit in the A0MUCTL register (see [page 31](#))

CSA = “1”: low resolution selected

CSA = “0”: high resolution selected

Half-bridge Over-temperature Protection

The outputs are protected against over-temperature conditions. Each power output comprises two different temperature thresholds.

The first threshold is the high temperature interrupt (HTI). If the temperature reaches this threshold, the HTIF bit in the Interrupt Flag Register (IFR) is set, and an interrupt will be initiated if the HTIE bit in the Interrupt Mask register is set. In addition, this interrupt can be used to automatically turn off the power stages. This shutdown can be enabled/disabled by the HTIS0-1 Bits in the System Control Register (SYSCTL).

The high temperature interrupts flag (HTIF) is cleared (and the outputs reenabled) by writing a “1” to the HTIF flag in the Interrupt Flag Register (IFR) or by a reset. Clearing this flag has no effect as long as a high temperature condition is present.

If the HTI shutdown is disabled, a second threshold high temperature reset (HTR) will be used to turn off all power stages (HB (all Fet’s), HS, HVDD, H0) in order to protect the device.

Half-Bridge Over-current Protection

The Half-bridges are protected against short to GND, VSUP, and load shorts. The over-current protection is implemented on each HB. If an over-current condition on the high side MOSFET occurs, the high side MOSFET is automatically switched off. An over-current condition on the low side MOSFET will automatically turn off the low side MOSFET. In both cases, the corresponding HBxOCF flag in the Half-bridge Status and Control Register (HBSCTL) is set.

The over-current status flag is cleared (and the corresponding half-bridge MOSFETs reenabled) by writing a “1” to the HBxOCF in the Half-bridge Status and Control Register (HBSCTL) or by a reset.

Half-bridge Over-voltage/Under-voltage Protection

The half-bridge outputs are protected against under-voltage and over-voltage conditions. This protection is done by the low and high voltage interrupt circuitry. If one of these flags (LVIF, HVIF) are set, the outputs are automatically disabled when the VIS bit in the System Control Register (SYSCTL) is cleared.

The over-voltage and under-voltage status flags are cleared (and the outputs reenabled) by writing a “1” to the LVIF / HVIF flags in the Interrupt Flag Register (IFR), or by a reset. Clearing this flag has no effect as long as the high voltage or low voltage condition is still present.

Half-bridge Status and Control Register (HBSCTL)

Register Name and Address: HBSCTL - \$03

	Bit7	6	5	4	3	2	1	Bit0
Read	CRM	0	0	0	HB4 OCF	HB3 OCF	HB2 OCF	HB1 OCF
Write								
Reset	0	0	0	0	0	0	0	0

CRM — Current Recirculation Mode bit

This read/write bit selects the recirculation mode during PWM. Reset clears the CRM bit.

- 1 = recirculation via switched on low side MOSFET
- 0 = recirculation via low side freewheeling diode

HBxOCF — Half-bridges Over-current Flag Bit

This read/write bit indicates that an over-current condition on either the LS or the HS FET on HBx has occurred.

Clear HBxOCF and enable half-bridge by writing a logic [1] to HBxOCF. Writing a logic [0] to HBxOCF has no effect. Reset clears the HBxOCF bit.

- 1 = over-current condition on HBx occurred
- 0 = no over-current condition on HBx

High Side Drivers

The high side outputs are low resistive high side switches, targeted for driving lamps. The high sides are protected against over-temperature, over-current, and over-voltage/under-voltage.

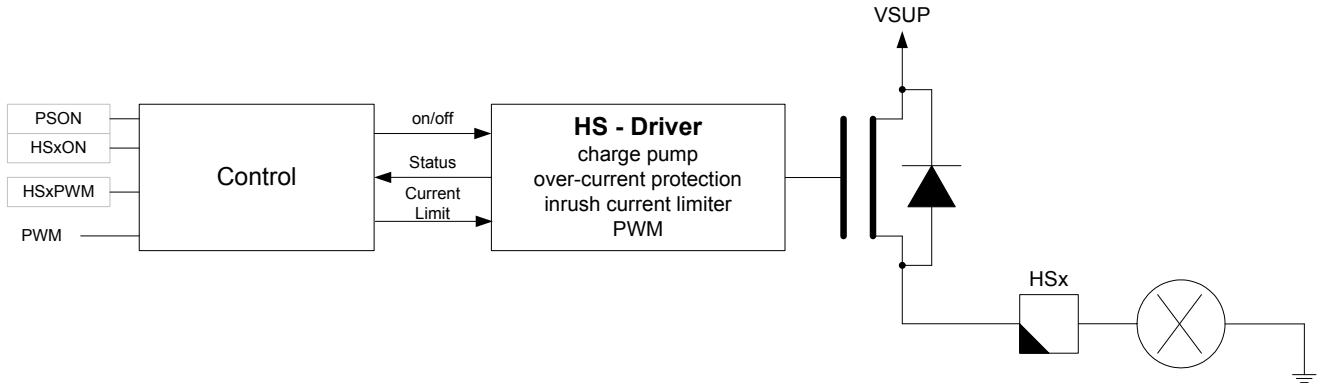

Figure 23. HS Circuitry

HIGH SIDE OPERATING MODES

The high side outputs are enabled if the PSON bit in the System Control Register (SYSCTL) is set.

Each high side output is permanently switched on, if the HSxON bit in the High Side Output Register (HSOUT) is set.

PWM control of the output is enabled, if the HSxPWM bit High Side Output Register (HSOUT) is set. In this operating mode, the high side MOSFET is on if the input PWM signal (PWM pin) is high.

The following table shows the behavior of the high side MOSFETs depending on the HSONx and PWMHSx bits.

Table 9. High Side Configuration Bits

HSxPWM	HSxON	Mode
0	0	High side MOSFET off
0	1	High side MOSFET on if over-current, the over-current flag (HSxOCF) is set, and the high side MOSFET is turned off
1	0	<p>In this mode, the PWM duty cycle is either controlled by the PWM input signal, or if the over-current shutdown value is reached by the part itself.</p> <p>Without reaching the over-current shutdown, the high side driver is directly driven from the PWM input signal. If the Input signal is high, the output is on. If low, the output is off (PWM control).</p> <p>If the current reaches the over-current shutdown value, the high side will be automatically turned off. With the next rising edge of the PWM input signal, the output will turn on again (current limitation). The HSxOCF bit will be set. The software has to distinguish between an inrush current and a real short on the output.</p>
1	1	<p>High side MOSFET is switched on and the inrush current limitation is enabled. This means the high side will start automatically with a current limitation around the over-current shutdown threshold. (PWM signal must be applied, see Figure 24)</p> <p>If the high side enters current limitation, the HSxOCF bit is set, but the output is not disabled. The software needs to distinguish between an inrush current and a real short on the output.</p>

High Side Over-voltage / Under-voltage Protection

The outputs are protected against under /over-voltage conditions. This protection is done by the low and high voltage interrupt circuitry. If an over /under-voltage condition is detected (LVIF / HVIF), and Bit VIS in the High Side Status Register is cleared, the output is disabled.

The over /under-voltage status flags are cleared (and the output reenabled), by writing a logic [1] to the LVIF / HVIF

flags in the Interrupt Flag Register, or by reset. Clearing this flag has no effect as long as a high or low voltage condition is present.

HIGH SIDE OVER-TEMPERATURE PROTECTION

The outputs are protected against over-temperature conditions.

Each power output comprises two different temperature thresholds.

The first threshold is the high temperature interrupt (HTI). If the temperature reach this threshold, the HTI bit in the interrupt flag register is set and an interrupt will be generated, if the HTIE bit in the interrupt mask register is set. In addition, this interrupt can be used to automatically turn off the power stages (all high sides, on Half-bridges just the high side FET's). This shutdown can be enabled/disabled by the HTISO bit.

The high temperature interrupts flag (HTIE) is cleared (and the outputs reenabled) by writing a logic [1] to the HTIF flag in the Interrupt Status Register, or by reset. Clearing this flag has no effect as long as a high temperature condition is present.

If the HTIS shutdown is disabled, a second threshold (HTR) will be used to turn off all power stages (HB (all Fet's), HS, HVDD, H0) in order to protect the device.

High Side Over-current Protection

The HS outputs are protected against over-current. When the over-current limit is reached, the output will be automatically switched off and the over-current flag is set.

Due to the high inrush current of bulbs, a special feature was implemented to avoid a over-current shutdown during this inrush current. If a PWM frequency will be supplied to the PWM input during the switch on of a bulb, the inrush current will be limited to the over-current shutdown limit. This means, if the current reaches the over-current shutdown, the high side will be switched off, but each rising edge on the PWM input will enable the driver again. The duty cycle supplied by the MCU has no influence on the switch-on time of the high side driver.

In order to distinguish between a shutdown due to an inrush current or a real shutdown, the software checks if the over-current status flag (HSxOCF) in the High Side Status register is set beyond a certain period of time.

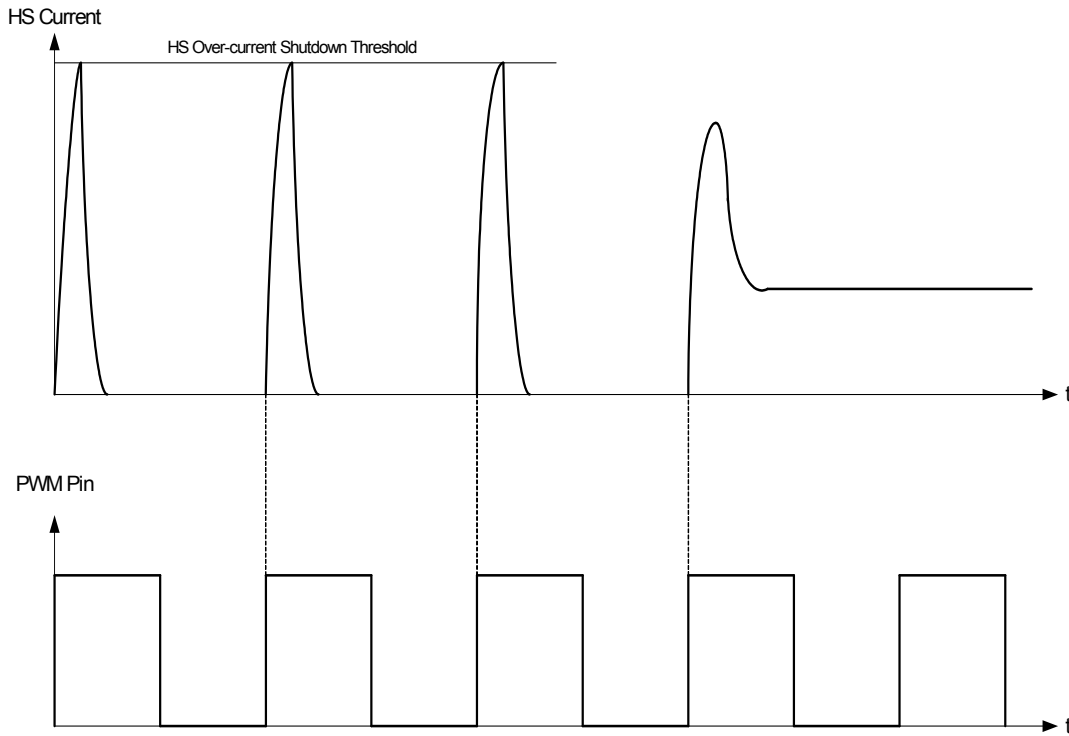

Figure 24. Inrush Current Limitation on HS Outputs

High Side Current Recopy

Each High Side has an additional sense output to allow a current recopy feature. This sense source is internally connected to a shunt resistor. The drop voltage is amplified and switched to the Analog Multiplexer.

Switchable HVDD Outputs

The HVDD pin is a switchable 5.0 V output pin. It can be used for driving external circuitry, which requires a 5.0 V voltage. The output is enabled with the PSON bit in the System Control register, and can be switched on / off with the HVDD_ON bit in the High Side Out register. Low or high voltage conditions (LVIF / HVIF) will have no influence on this circuitry.

HVDD Over-temperature Protection

The output is protected against over-temperature conditions.

HVDD Over-current Protection

The HVDD output is protected against over-current. In case the current reaches the over-current limit, the output current will be limited, and the HVDDOCF over-current flag in the System Status register is set.

HIGH SIDE OUT REGISTER (HSOUT)

Register Name and Address: HSOUT - \$02

	Bit7	6	5	4	3	2	1	Bit0
Read	HVDD ON	0	HS3P WM	HS2P WM	HS1P WM	HS3O N	HS2O N	HS1O N
Write								
Reset	0	0	0	0	0	0	0	0

HVDD-ON — HVDD On Bit

This read/write bit enables the HVDD output. Reset clears HVDDON bit.

- 1 = HVDD enabled
- 0 = HVDD disabled

HSxON — High Side on/off Bits

These read/write bits turn on the High Side Fet's permanently. Reset clears the HSxON bits.

- 1 = High Side x is turned on
- 0 = High Side x is turned off

HSxPWM — High Side PWM on/off Bits

These read/write bits enable the PWM control of the High Side Fet's. Reset clears the HSxPWM bits.

- 1 = High Side x is controlled by PWM input signal
- 0 = High Side x is not controlled by PWM input signal

High Side Status Register (HSSTAT)

Register Name and Address: HSSTAT - \$04

	Bit7	6	5	4	3	2	1	Bit0
Read	HVDD OCF	0	0	0	0	HS3O CF	HS2O CF	HS1O CF
Write								
Reset	0	0	0	0	0	0	0	0

HSxOCF — High Side Over-current Flag Bit

This read/write flag is set by an over-current condition at the high side drivers x. Clear HSxOCF and enable the HS Driver by writing a logic [1] to HSxOCF. Writing a logic [0] to HSxOCF has no effect. Reset clears the HSxOCF bit.

- 1 = over-current condition on high side drivers has occurred
- 0 = no over-current condition on high side drivers has occurred

HVDDOCF — HVDD Output Over-current Flag Bit

This read/write flag is set by an over-current condition at HVDD pin. Clear HVDDOCF and enable the output by writing a logic [1] to the HVDDOCF Flag. Writing a logic [0] to HVDDOCF has no effect. Reset clears the HVDDOCF bit.

- 1 = over-current condition on VDD output has occurred
- 0 = no over-current condition on VDD output has occurred

System Control Register (SYSCTL)

Register Name and Address: SYSCTL - \$00

	Bit7	6	5	4	3	2	1	Bit0
Read	PSON	0	0	HTIS1	HTIS0	VIS	SRS1	SRS0
Write		STOP	SLEEP					
Reset	0	0	0	0	0	0	0	0

PSON — Power Stages On Bit

This read/write bit enables the power stages (half-bridges, high sides, LIN transmitter, A0 Current Sources and HVDD output). Reset clears the PSON bit.

- 1 = power stages enabled
- 0 = power stages disabled

STOP — Change to STOP Mode Bit

This write bit instructs the chip to enter Stop mode (See [Operational Modes on page 24](#)). Reset or CPU interrupt requests clear the STOP bit.

- 1 = go to Stop mode
- 0 = not in stop mode

In order to safely enter Stop mode, all other bits (Bit7-Bit2) have to be "0". Otherwise the STOP command will not execute.

SLEEP — Change to SLEEP Mode Bit

This write bit instructs the chip to enter Sleep mode (See [Operational Modes on page 24](#)). Reset or CPU interrupt requests clear the SLEEP bit.

- 1 = go to Sleep mode
- 0 = not in sleep mode

In order to safely enter Sleep mode all other bits (Bit7-Bit2) have to be "0". Otherwise the SLEEP command will not execute.

HTIS0-1 — High Temperature Interrupt Shutdown Bits

This read/write bit selects the power stage behavior at High Temperature Interrupt (HTI). Reset clears the HTIS0-1 bits.

The HTIS0 bit selects the behavior of the high side HS1:3 and the high side FET of the half-bridges HB1:4.

- 1 = automatic HTI shutdown of the high side drivers disabled
- 0 = automatic HTI shutdown of the high side drivers enabled

The HTIS1 bit selects the behavior of the low side drivers of the half-bridges HB1:4.

- 1 = automatic HTI shutdown of the low side drivers disabled
- 0 = automatic HTI shutdown of the low side drivers enabled

The user has to take care to protect the device against thermal destruction!

VIS — Over/Under-voltage Interrupt Shutdown

This read/write bit selects the power stage behavior at LVI/HVI. Reset clears the VIS bit.

- 1 = automatic LVI/HVI shutdown disabled
- 0 = automatic LVI/HVI shutdown enabled

SRS0-1 — LIN Slew Rate Select Bits

These read/write bits enable the user to select the appropriate LIN slew rate for different Baudrate configurations. Reset clears the SRS1:0 bits.

Table 10. LIN Slew Rate Selection Bits

SRS1	SRS0	Slew rate
0	0	Initial Slew Rate (20 kBaud)
0	1	High Speed II (8x)
1	0	Slow Slew Rate (10 kBaud)
1	1	High Speed I (4x)

The high speed slew rates are used, for example, for programming via the LIN, and are not intended for use in the application.

System Status Register (SYSSTAT)

Register Name and Address: SYSSTAT - \$0C

	Bit7	6	5	4	3	2	1	Bit0
Read	LINCL	HTIF	VF	H0F	HVDDF	HSF	HBF	0
Write								
Reset	0	0	0	0	0	0	0	0

LINCL — LIN Current Limitation Bit

This read only bit is set if the LIN transmitter operates in current limitation region. Due to excessive power dissipation in the transmitter, the driver will be automatically turned off after a certain time.

- 1 = transmitter operating in current limitation region
- 0 = transmitter not operating in current limitation region

HTIF— Over-temperature Status Bit

This read only bit is a copy of the HTIF bit in the Interrupt Flag register

- 1 = over-temperature condition
- 0 = no over-temperature condition

VF — Voltage Failure Bit

This read only bit indicates that the supply voltage was out of the allowed range. The bit is set if either the LVIF or the HVIF in the Interrupt Flag register is set.

- 1 = low/high voltage condition detected
- 0 = no voltage failure condition detected

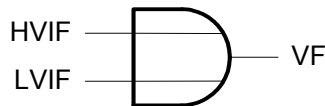

Figure 25. VF Flag Generation

H0F — H0 Failure Bit

This read only bit is a copy of the H0OCF bit in the H0/L0 Status and Control Register (HLSCTL)

- 1 = over-current detected on H0
- 0 = no over-current on H0

HVDDF— HVDD Failure Bit

This read only bit is a copy of the HVDDOCF bit in the High Side Status register

- 1 = HVDD pin fail
- 0 = HVDD normal operating

HSF— HS1:3 Failure Bit

This read only bit is set if a fail condition on one of the high side outputs is present

- 1 = HS1:3 pin fail
- 0 = HS1:3 normal operating

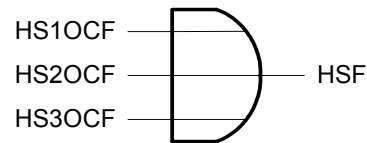

Figure 26. HSF Flag Generation

HBF— HB1:4 Failure Bit

This read only bit is set if a fail condition on one of the half-bridge outputs is present.

- 1 = HB1:4 pin over-current fail
- 0 = HB1:4 normal operating

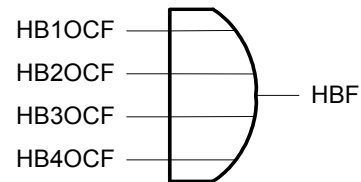

Figure 27. HBF Flag Generation

WINDOW WATCHDOG

The window watchdog is used to supervise the device, and to recover from, e.g. code runaways, or similar conditions.

The use of a window watchdog adds additional safety, as the watchdog clear has not only to occur, but be done at a certain time frame / window.

Normal mode

The window watchdog function is only available in Normal mode, and is halted in Stop and Sleep mode. On setting the WDRE bit, the watchdog functionality is activated. Once this function is enabled, it is not possible to disable it via software. Reset clears the WDRE bit.

To prevent a Watchdog reset, the Watchdog timer has to be cleared in the Window Open frame. This is done by writing a logic "1" to the WDRST bit in the Watchdog Control register (WDCTL). The actual reset of the watchdog counter occurs at the end of the corresponding SPI transmission, with the rising edge of the SS signal.

If the watchdog is enabled, it will generate a system reset, if the timer has reached its end value, or if a watchdog reset (WDRST) has occurred in the closed window.

The watchdog period can be selected with 2 bits in the WDCTL, in order to get 10ms, 20ms, 40ms and 80ms period.

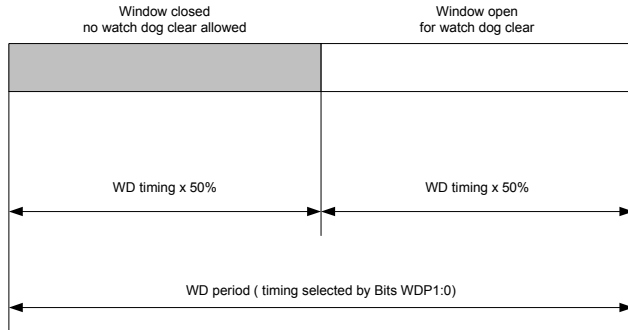

Figure 28. Window Watchdog Period

Stop mode

Operations of the watchdog function is halted in stop mode (counter/oscillator stopped). After wake-up, the watchdog timer is automatically cleared, in order to give the MCU the full time to reset the watchdog.

Sleep mode

Operations of the watchdog function is halted in sleep mode. Because the main voltage regulator asserts an LVR reset, the Watchdog functionality is disabled, and the WDRE bit is cleared as soon as sleep mode is entered. To re-enable this function bit WDRE has to be set after wake-up.

Watchdog Control Register (WDCTL)

Register Name and Address: WDCTL - \$0B

	Bit7	6	5	4	3	2	1	Bit0
Read	WDRE	WDP1	WDP0	0	0	0	0	0
Write								WDRST
Reset	0	0	0	0	0	0	0	0

WDRE - Watchdog Reset Enable Bit

This read/write (write once) bit activates the watchdog. The WDRE can only be set and can not be cleared by software. Reset clears the WDRE bit.

1 = Watchdog enabled
0 = Watchdog disabled

WDP1:0 - Watchdog Period Select Bits

This read/write bit select the clock rate of the Watchdog. Reset clears the WDP1:0 bits.

Table 11. Watchdog Period Selection Bits

WDP1	WDP0	Mode
0	0	80 ms window watchdog period
0	1	40 ms window watchdog period
1	0	20 ms window watchdog period
1	1	10 ms window watchdog period

WDRST - Watchdog Reset Bit

This write only bit resets the Watchdog. Write a logic [1] to reset the watchdog timer.

1 = Reset WD and restart timer
0 = no effect

Voltage Regulator

The 908E621 contains a low power, low drop voltage regulator, to provide internal power and external power for the MCU. The on-chip regulator consist of two elements, the main regulator and the low voltage reset circuit.

The V_{DD} regulator accepts an unregulated input supply and provides a regulated V_{DD} supply to all digital sections of the device. The output of the regulator is also connected to the VDD pin to provide the 5.0 V to the microcontroller.

Run mode

During RUN mode the main voltage regulator is on. It will provide a regulated supply to all digital sections.

STOP mode

During STOP mode, the Stop mode regulator will take care of supplying a regulated output voltage. The Stop mode regulator has a limited output current capability.

SLEEP mode

In Sleep mode, the main voltage regulator external, V_{DD} , is turned off and the LVR circuitry will force the RST_A pin low.

LOGIC COMMANDS AND REGISTERS

908E621 SERIAL PHERIPHERAL INTERFACE (SPI)

The Serial Peripheral Interface (SPI) creates the communication link between the MCU and the analog die.

The interface consists of four pins

- MOSI - Master Out Slave In (internal pulldown)

- MISO - Master In Slave Out
- SPCK - Serial Clock (internal pulldown)
- \overline{SS} - Slave Select (internal pullup)

A complete data transfer via the SPI, consists of 2 bytes. The master sends address and data, the slave returns system status and the data of the selected address.

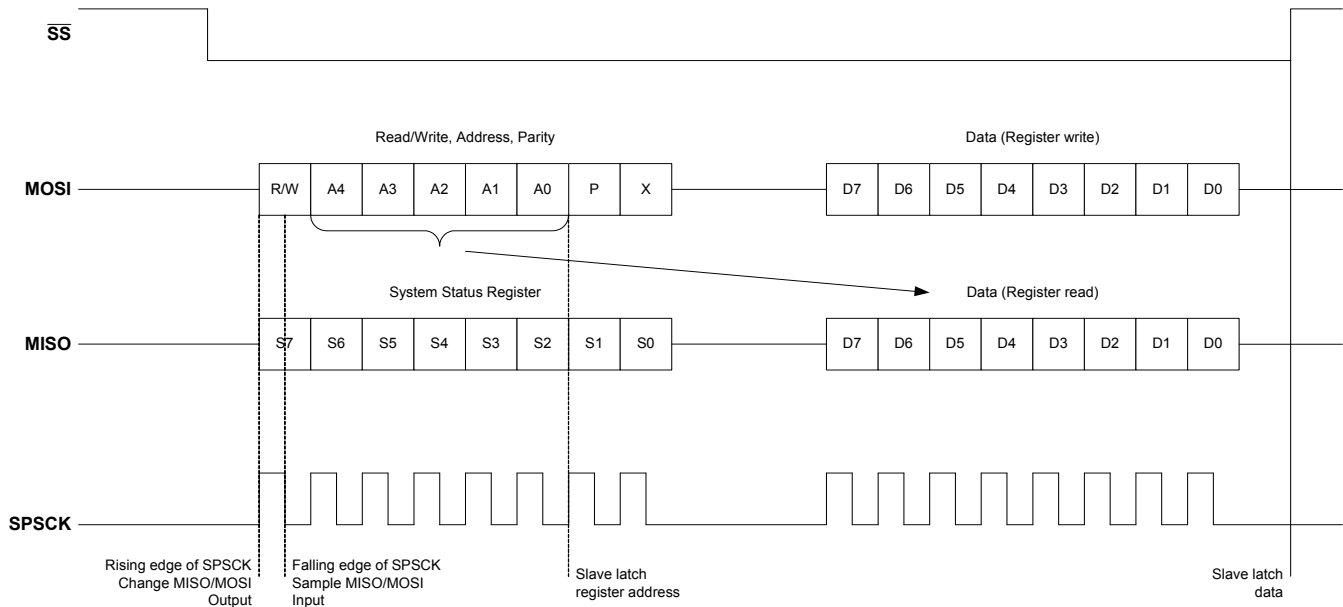

Figure 29. SPI Protocol

- During the inactive phase of \overline{SS} , the new data transfer will be prepared. The falling edge on the \overline{SS} line, indicates the start of a new data transfer (framing), and puts MISO in the low impedance mode. The first valid data are moved to MISO with the rising edge of SPSCCK.
- The MOSI, MISO will change data on a rising edge of SPSCCK.
- The MOSI, MISO will be sampled on a falling edge of SPSCCK.
- The data transfer is only valid, if exactly 16 sample clock edges are present in the active phase of \overline{SS} .
- After a write operation, the transmitted data will be latched into the register by the rising edge of \overline{SS} .
- Register read data is internally latched into the SPI at the time when the parity bit is transferred
- \overline{SS} high will force MISO to high-impedance

Master Address Byte

A4 - A0

Includes the address of the desired register.

$\overline{R/W}$

Includes the information, if it is a read or a write operation.

- If $\overline{R/W} = 1$ (read operation), the second byte of master contains no valid information, and the slave just transmits back register data.
- If $\overline{R/W} = 0$ (write operation), the master sends data to be written in the second byte, the slave sends concurrently contents of selected register prior to write operation,

and the write data is latched in the *SMARTMOS* registers on rising edge of \overline{SS} .

Parity P

Completes the total number of 1 bits of (R/W,A[4-0]) to an even number. e.g. (R/W,A[4-0]) = 100001 -> P0 = 0.

The parity bit is only evaluated during a write operations and ignored for read operations.

Bit X

Not used

Master Data Byte

This byte includes data to be written, or no valid data, during a read operation.

Slave Status Byte

This byte always includes the contents of the system status register (\$0C), independent if it is a write or read operation, or which register was selected.

Slave Data Byte

This byte includes the contents of selected register, during a write operation, it includes the register content prior to the write operation.

SPI REGISTER OVERVIEW

[Table 12](#) summarizes the SPI Register addresses and the bit names of each register.

Table 12. SPI Register Overview

Addr	Register Name	R/W	Bit							
			7	6	5	4	3	2	1	0
\$00	System Control (SYSCTL)	R	PSON	0	0	HTIS1	HTIS0	VIS	SRS1	SRS0
		W		STOP	SLEEP					
\$01	Half-bridge Output (HBOUT)	R	HB4_H	HB4_L	HB3_H	HB3_L	HB2_H	HB2_L	HB1_H	HB1_L
		W								
\$02	High Side Output (HSOUT)	R	HVDDON	0	HS3PWM	HS2PWM	HS1PWM	HS3ON	HS2ON	HS1ON
		W								
\$03	Half-bridge Status and Control (HBSCTL)	R	CRM	0	0	0	HB4OCF	HB3OCF	HB2OCF	HB1OCF
		W								
\$04	High Side Status and Control (HSSCTL)	R	HVDDOCF	0	0	0	0	HS3OCF	HS2OCF	HS1OCF
		W								
\$05	Reserved	R	reserved							
		W	reserved							
\$06	Reserved	R	reserved							
		W	reserved							
\$07	H0/L0 Status and Control (HLSCTL)	R	L0F	0	0	H0OCF	H0F	H0EN	H0PD	H0MS
		W								
\$08	A0 and Multiplexer Control (A0MUCTL)	R	CSON	CSSEL1	CSSEL0	CSA	SS3	SS2	SS1	SS0
		W								
\$09	Interrupt Mask (IMR)	R	L0IE	H0IE	LINIE	HTRD	HTIE	LVIE	HVIE	PSFIE
		W								
\$0A	Interrupt Flag (IFR)	R	L0IF	H0IF	LINIF	0	HTIF	LVIF	HVIF	PSFIF
		W								
\$0B	Watchdog Control (WDCTL)	R	WDRE	WDP1	WDP0	0	0	0	0	0
		W								
\$0C	System Status (SYSSTAT)	R	LINCL	HTIF	VF	H0F	HVDDF	HSF	HSF	0
		W								
\$0D	Reset Status (RSR)	R	POR	PINR	WDR	HTR	LVR	0	LINWF	LOWF
		W								
\$0E	System Test (SYSTEST)	R	reserved							
		W	reserved							
\$0F	System Trim 1 (SYSTRIM1)	R	HVDDT1	HVDDT0	reserved	reserved	itrim3	itrim2	itrim1	itrim0
		W								
\$10	System Trim 2 (SYSTRIM2)	R	0	0	0	0	0	0	0	0
		W	CRHBHC1	CRHBHC0	CRHB5	CRHB4	CRHB3	CRHB2	CRHB1	CRHB0
\$11	System Trim 3 (SYSTRIM3)	R	0	0	0	0	0	0	0	0
		W	CRHS3	CRHS2	CRHS5	CRHS4	CRHS3	CRHS2	CRHS1	CRHS0

FACTORY TRIMMING AND CALIBRATION

To enhance the ease-of-use of the 908E621, various parameters (e.g. ICG trim value) are stored in the flash memory of the device. The following flash memory locations are reserved for this purpose and might have a value different from the “empty” (\$FF) state:

- \$FD80:\$FDFF Trim and Calibration Values
- \$FFFE:\$FFFF Reset Vector

In the event the application uses these parameters, one has to take care not to erase or override these values. If these parameters are not used, these flash locations can be erased and otherwise used.

Trim Values

The usage of the trim values located in the flash memory are explained through the following:

Internal Clock Generator (ICG) Trim Value

The internal clock generator (ICG) module is used to create a stable clock source for the microcontroller without using any external components. The untrimmed frequency of the low frequency base clock (IBASE), will vary as much as ±25 percent due to process, temperature, and voltage dependencies. To compensate these dependencies, an ICG trim value is located at address \$FDC2. After trimming, the ICG has a typ. range of ±2% (±3% max.), at nominal conditions (filtered (100nF), stabilized (4.7 μF) $V_{DD} = 5.0 V$, $T_{AMBIENT} \sim 25^{\circ}C$), and will vary over temperature and voltage (V_{DD}) as indicated in the 68HC908EY16 datasheet.

To trim the ICG, this value has to be copied to the ICG Trim Register ICGTR at address \$38 of the MCU.

Important: The value must be copied after every reset.

Watchdog Period Range Value (AWD Trim)

The window watchdog supervises device recovery (e.g. from code runaways).

The application software has to clear the watchdog within the open window. Due to the high variation of the watchdog period, and therefore the reduced width of the watchdog window, a value is stored at address \$FDCF. This value classifies the watchdog period into 3 ranges (Range 0, 1, 2). This allows the application software to select one of three time intervals to clear the watchdog, based on the stored value. The classification is done, so that the application software can have up to ±19% variations of the optimal clear interval (e.g. caused by ICG variation).

Effective Open Window

Having a variation in the watchdog period in conjunction with a 50% open window, results in an effective open window, which can be calculated by:

$$\text{latest window open time: } t_{\text{open}} = t_{\text{wd max}} / 2$$

$$\text{earliest window closed time: } t_{\text{closed}} = t_{\text{wd min}}$$

Optimal Clear Interval

The optimal clear interval, meaning the clear interval with the biggest possible variation to latest window open time, and to the earliest window closed time, can be calculated with the following formula:

$$t_{\text{opt}} = t_{\text{open}} + (t_{\text{open}} + t_{\text{closed}}) / 2$$

See Table 13 to select the optimal clear interval for the watchdog based on the Window No. and chosen period.

Table 13. Window Clear Interval

Window Range	Period Select bits	Watchdog Period t_{wd}			Effective Open Window			Optimal Clear Interval			
		\$FDCF	WDP1:0	min.	max.	Unit	t_{open}	t_{closed}	Unit	t_{opt}	Unit
0	00		68	92	ms	46	68	ms	57	ms	±19.3%
	01		34	46		23	34		28.5		
	10		17	23		11.5	17		14.25		
	11		8.5	11.5		5.75	8.5		7.125		
1	00		92	124	ms	62	92	ms	77	ms	±19.5%
	01		46	62		31	46		38.5		
	10		23	31		15.5	23		19.25		
	11		11.5	15.5		7.75	11.5		9.625		
2	00		52	68	ms	34	52	ms	43	ms	±20.9%
	01		26	34		17	26		21.5		
	10		13	17		8.5	13		10.75		
	11		6.5	8.5		4.25	6.5		5.375		

Analog Die System Trim Values

For improved application performance, and to ensure the outlined datasheet values, the analog die needs to be trimmed. For this purpose, 3 trim values are stored in the Flash memory at addresses \$FDC4 - \$FDC6. These values have to be copied into the analog die SPI registers:

- copy \$FDC4 into SYSTRIM1 register \$0F
- copy \$FDC5 into SYSTRIM2 register \$10
- copy \$FDC6 into SYSTRIM3 register \$11

Note: These values must be copied to the respective SPI register after a reset, to ensure proper trimming of the device.

System Test Register (SYSTEST)

Register Name and Address: SYSTEST - \$0E

	Bit7	6	5	4	3	2	1	Bit0
Read	reserved	reserved	reserved	reserved	reserved	reserved	reserved	reserved
Write	reserved	reserved	reserved	reserved	reserved	reserved	reserved	reserved
Reset	0	0	0	0	0	0	0	0

Note: do not write to the reserved bits

The System Test Register is reserved for production testing and is not allowed to be written to.

System Trim Register 1 (SYSTRIM1)

Register Name and Address: IBIAS - \$0F

	Bit7	6	5	4	3	2	1	Bit0
Read	HVDDT1	HVDDT0	0 reserved	0 reserved	ITRIM3	ITRIM2	ITRIM1	ITRIM0
Write								
Reset	0	0	0	0	0	0	0	0

Note: do not change (set) the reserved bits

HVDDT1:0 - HVDD Over-current Shutdown Delay Bits

These read/write bits allow changes to the filter time (for capacitive load) for HVDD over-current detection. Reset clears the HVDDT1:0 bits and sets the delay to the maximum value.

Table 14. HVDD Over-current Shutdown Selection Bits

HVDDT1	HVDDT0	Typical Delay
0	0	950 μ s
0	1	536 μ s
1	0	234 μ s
1	1	78 μ s

ITRIM3:0 - IRef Trim Bits

These write only bits are for trimming the internal current references IRef (also A0, A0CST). The provided trim values have to be copied into these bits after every reset. Reset clears the ITRIM3:0 bits.

Table 15. IRef Trim Bits

itrim3	itrim2	itrim2	itrim0	Adjustment
0	0	0	0	0
0	0	0	1	2%
0	0	1	0	4%
0	0	1	1	8%
0	1	0	0	12%
0	1	0	1	-2%
0	1	1	0	-4%
0	1	1	1	-8%
1	0	0	0	-12%

System Trim Register 2 (SYSTRIM2)

Register Name and Address: IFBHBTRIM - \$10

	Bit7	6	5	4	3	2	1	Bit0
Read	0	0	0	0	0	0	0	0
Write	CRHBHC1	CRHBHC0	CRHB5	CRHB4	CRHB3	CRHB2	CRHB1	CRHB0
Reset	0	0	0	0	0	0	0	0

CRHBHC1:0 - Current Recopy HB1:2 Trim Bits

These write only bits are for trimming the current recopy of the half-bridge HB1 and HB2 (CSA=0). The provided trim values have to be copied into these bits after every reset. Reset clears the CRHBHC1:0 bits.

Table 16. Current Recopy Trim for HB1:2 (CSA=0)

CRHBHC1	CRHBHC0	Adjustment
0	0	0
0	1	-10%
1	0	5%
1	1	10%

CRHB5:3 - Current Recopy HB3:4 Trim Bits

These write only bits are for trimming the current recopy of the half-bridge HB3 and HB4 (CSA=1). The provided trim values have to be copied into these bits after every reset. Reset clears the CRHB5:3 bits.

Table 17. Current Recopy Trim for HB3:4 (CSA=1)

CRHB5	CRHB4	CRHB3	Adjustment
0	0	0	0
0	0	1	-5%
0	1	0	-10%
0	1	1	-15%
1	0	0	reserved
1	0	1	5%
1	1	0	10%
1	1	1	15%

CRHB2:0 - Current Recopy HB1:2 Trim Bits

These write only bits are for trimming the current recopy of the half-bridge HB1 and HB2 (CSA=1). The provided trim values have to be copied into these bits after every reset. Reset clears the CRHB2:0 bits.

Table 18. Current Recopy Trim for HB1:2 (CSA=1)

CRHB2	CRHB1	CRHB0	Adjustment
0	0	0	0
0	0	1	-5%
0	1	0	-10%
0	1	1	-15%
1	0	0	reserved
1	0	1	5%
1	1	0	10%
1	1	1	15%

System Trim Register 3 (SYSTRIM3)

Register Name and Address: **IFBHSTRIM - \$11**

	Bit7	6	5	4	3	2	1	Bit0
Read	0	0	0	0	0	0	0	0
Write	CRHBH C3	CRHBH C2	CRHS5	CRHS4	CRHS3	CRHS2	CRHS1	CRHS0
Reset	0	0	0	0	0	0	0	0

CRHBHC3:2 - Current Recopy HB3:4 Trim Bits

These write only bits are for trimming the current recopy of the half-bridge HB3 and HB4 (CSA=0). The provided trim values have to be copied into these bits after every reset. Reset clears the CRHBHC3:2 bits.

Current Recopy Trim for HB3:4 (CSA=0)

CRHBHC3	CRHBHC2	Adjustment
0	0	0
0	1	-10%
1	0	5%
1	1	10%

CRHS5:3 - Current Recopy HS2:3 Trim Bits

These write only bits are for trimming the current recopy of the high side HS2 and HS3. The provided trim values have to be copied into these bits after every reset. Reset clears the CRHS5:3 bits.

Table 19. Current Recopy Trim for HS2:3

CRHS5	CRHS4	CRHS3	Adjustment
0	0	0	0
0	0	1	-5%
0	1	0	-10%
0	1	1	-15%
1	0	0	reserved
1	0	1	5%
1	1	0	10%
1	1	1	15%

CRHS2:0 - Current Recopy HS1 Trim Bits

These write only bits are for trimming the current recopy of the high side HS1. The provided Trim values have to be copied into these bits after every reset. Reset clears the CRHS2:0 bits.

Current Recopy Trim for HS1

CRHS2	CRHS1	CRHS0	Adjustment
0	0	0	0
0	0	1	-5%
0	1	0	-10%
0	1	1	-15%
1	0	0	reserved
1	0	1	5%
1	1	0	10%
1	1	1	15%

TYPICAL APPLICATIONS

DEVELOPMENT SUPPORT

As the 908E621 has the MC68HC908EY16 MCU embedded, typically all the development tools available for the MCU also apply for this device. However, due to the additional analog die circuitry and the nominal +12 V supply voltage, some additional items have to be considered:

- nominal 12 V rather than the 5.0 or 3.0 V supply
- high voltage V_{TST} might be applied not only to \overline{IRQ} pin, but $\overline{IRQ_A}$ pin
- MCU monitoring (Normal request timeout) has to be disabled

For a detailed information on the MCU related development support, see the MC68HC908EY16 datasheet - section development support.

The programming is principally possible at two stages in the manufacturing process, first on chip level, before the IC is soldered onto a pcb board, and second after the IC is soldered onto the pcb board.

Chip level programming

At the Chip level, the easiest way is to only power the MCU with +5.0 V (see [Figure 30](#)), and not to provide the analog chip with V_{SUP} . In this setup, all the analog pins should be left open (e.g. $V_{SUP}[1:8]$), and interconnections between the MCU and analog die have to be separated (e.g. $\overline{IRQ} - \overline{IRQ_A}$).

This mode is well described in the MC68HC908EY16 datasheet, section development support.

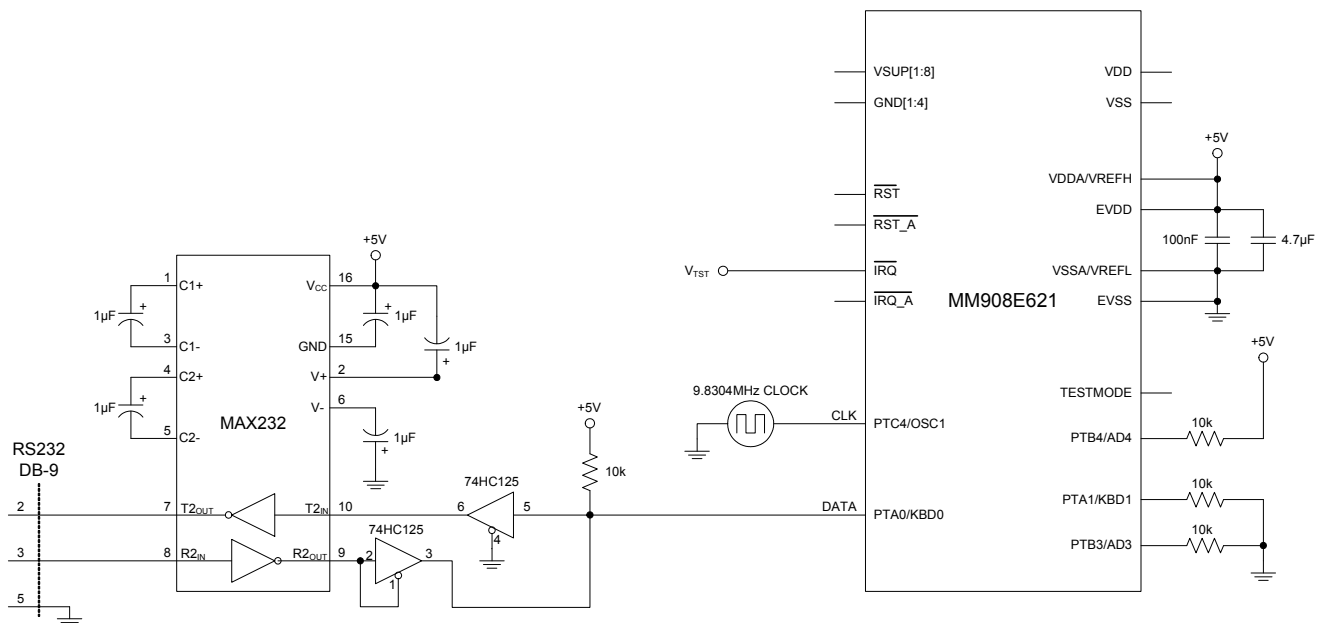

Figure 30. Normal Monitor Mode Circuit (MCU only)

Of course it is also possible to supply the whole system with V_{SUP} instead (12 V) as described in [Figure 31](#), page 50.

PCB level programming

If the IC is soldered onto the pcb board, it is typically not possible to separately power the MCU with +5.0 V. The whole system has to be powered up providing V_{SUP} (see [Figure 31](#)).

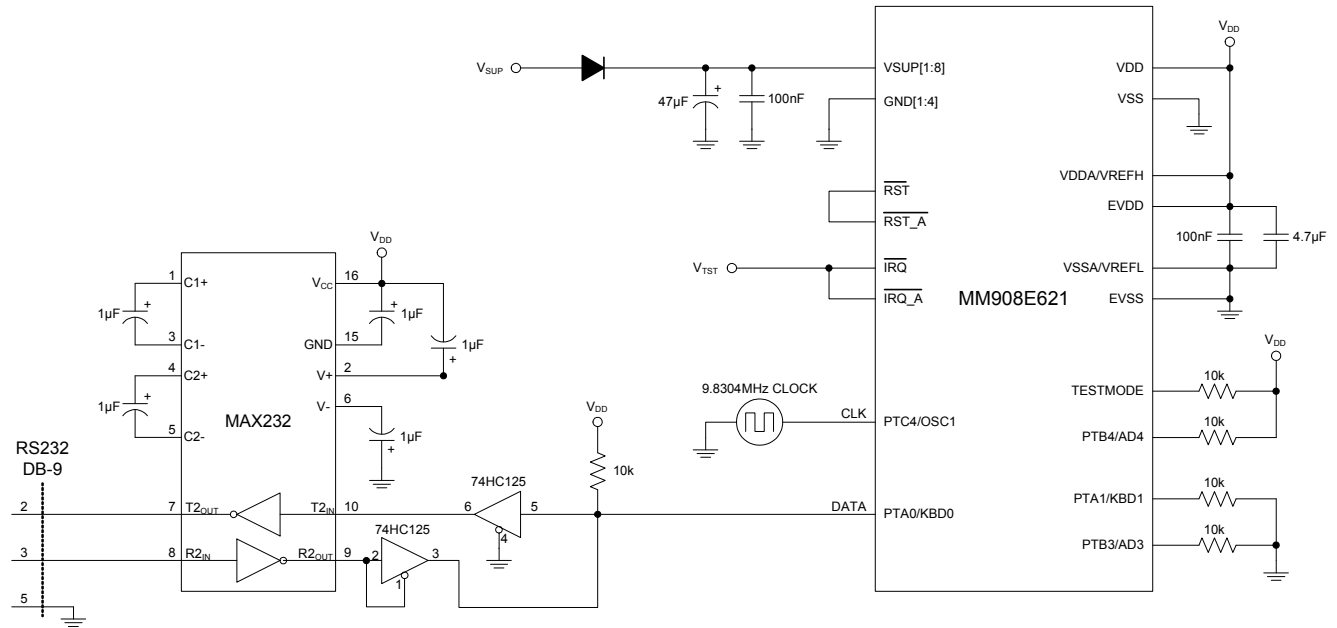

Figure 31. Normal Monitor Mode Circuit

Table 20 summarizes the possible configurations and the necessary setups.

Table 20. Monitor Mode Signal Requirements and Options

Mode	IRQ	RST	TESTMODE	Reset Vector	Serial Communication		Mode Selection		ICG	COP	Normal Request Time-out	Communication Speed		
					PTA0	PTA1	PTB3	PTB4				External Clock	Bus Frequency	Baud Rate
Normal Monitor	V _{TST}	V _{DD}	1	X	1	0	0	1	OFF	disabled	disabled	9.8304 MHz	2.4576 MHz	9600
Forced Monitor	V _{DD}	V _{DD}	1	\$FFFF (blank)	1	0	X	X	OFF	disabled	disabled	9.8304 MHz	2.4576 MHz	9600
	GND								ON	disabled	disabled	—	Nominal 1.6 MHz	Nominal 6300
User	V _{DD}	V _{DD}	0	not \$FFFF (not blank)	X	X	X	X	ON	enabled	enabled	—	Nominal 1.6 MHz	Nominal 6300

Notes

- 36. PTA0 must have a pullup resistor to V_{DD} in monitor mode
- 37. External clock is a 4.9152 MHz, 9.8304 MHz or 19.6608 MHz canned oscillator on OCS1
- 38. Communication speed with external clock is depending on external clock value. Baud rate is bus frequency / 256
- 39. X = don't care
- 40. V_{TST} is a high voltage V_{DD} + 3.5 V ≤ V_{TST} ≤ V_{DD} + 4.5 V

EMC/EMI RECOMMENDATIONS

This paragraph gives some device specific recommendations to improve EMC/EMI performance. Further generic design recommendations can be found on the Freescale web site www.freescale.com.

VSUP Pins (VSUP[1:8])

It is recommended to place a high quality ceramic decoupling capacitor close to the VSUP pins to improve EMC/EMI behavior.

LIN Pin

For DPI (Direct Power Injection) and ESD (Electrostatic Discharge), it is recommended to place a high quality ceramic decoupling capacitor near the LIN pin. An additional varistor will further increase the immunity against ESD. A ferrite in the LIN line will suppress some of the noise induced.

Voltage Regulator Output Pins (VDD and VSS)

Use a high quality ceramic decoupling capacitor to stabilize the regulated voltage.

MCU Digital Supply Pins (EVDD and EVSS)

Fast signal transitions on MCU pins place high, short duration current demands on the power supply. To prevent

noise problems, take special care to provide power supply bypassing at the MCU. It is recommended that a high quality ceramic decoupling capacitor be placed between these pins.

MCU Analog Supply Pins (VREFH/VDDA and VREFL/VSSA)

To avoid noise on the analog supply pins, it is important to take special care on the layout. The MCU digital and analog supplies should be tied to the same potential via separate traces, and connected to the voltage regulator output.

[Figure 32](#) and [Figure 33](#) show the recommendations on schematics and layout level, and [Table 21](#) indicates recommended external components and layout considerations.

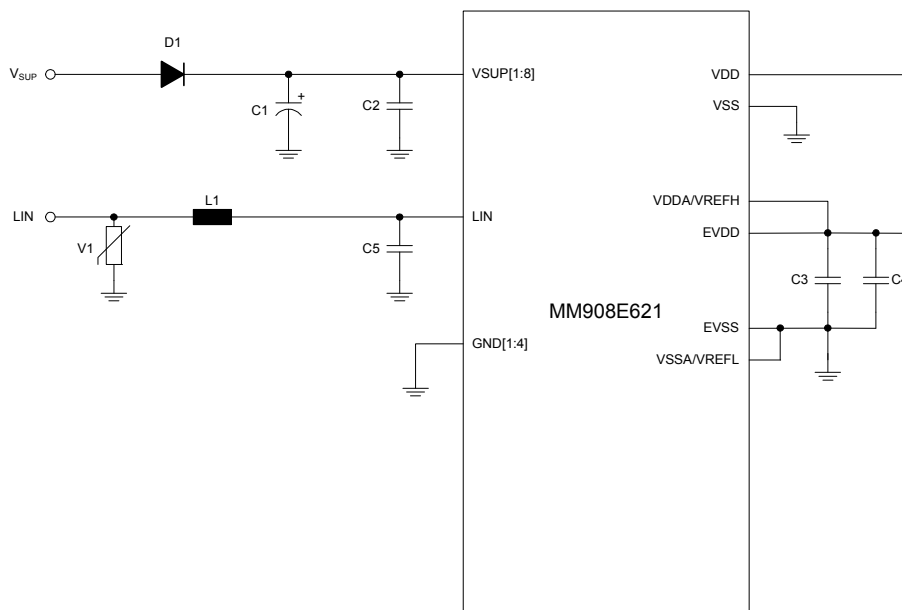

Figure 32. EMC/EMI recommendations

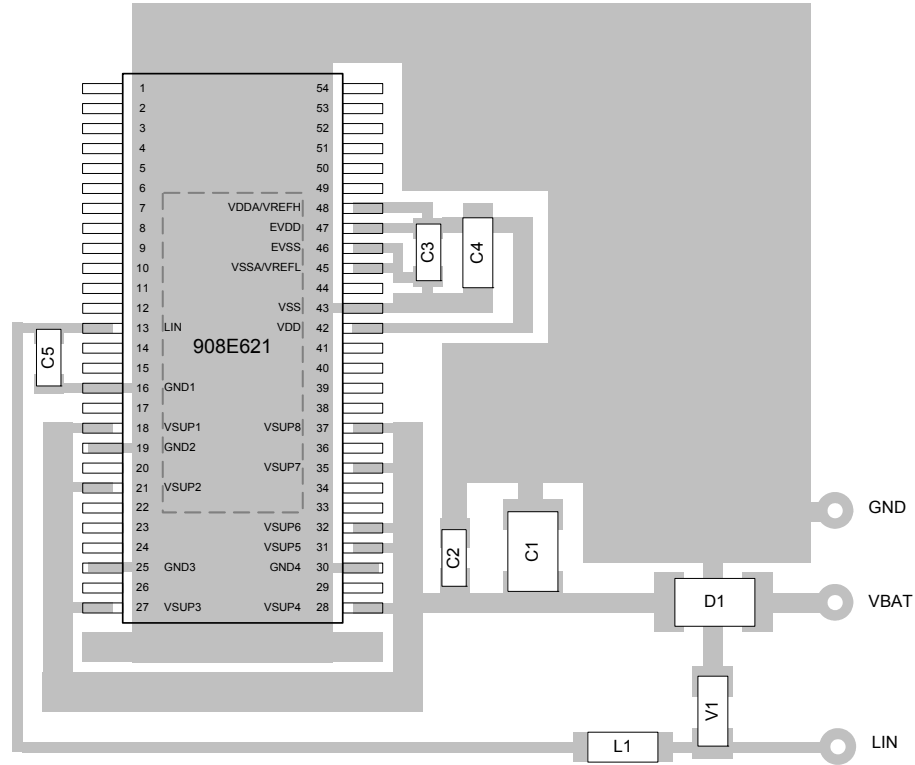

Figure 33. PCB Layout Recommendations

Table 21. Component Value Recommendation

Component	Recommended Value ⁽⁴¹⁾	Comments / Signal routing
D1		reverse battery protection
C1	Bulk Capacitor	
C2	100nF, SMD Ceramic, Low ESR	Close to VSUP pins with good ground return
C3	100nF, SMD Ceramic, Low ESR	Close (<3mm) to digital supply pins (EVDD, EVSS) with good ground return. The positive analog (VREFH/ VDDA) and the digital (EVDD) supply should be connected right at the C3.
C4	4,7µF, SMD Ceramic, Low ESR	Bulk Capacitor
C5	180pF, SMD Ceramic, Low ESR	Close (<5mm) to LIN pin. Total Capacitance on LIN has to be below 220pF. ($C_{total} = C_{LIN-Pin} + C5 + C_{Varistor} \sim 10pF + 180pF + 15pF$)
V1 ⁽⁴²⁾	Varistor Type TDK AVR-M1608C270MBAAB	Optional (close to LIN connector)
L1 ⁽⁴²⁾	SMD Ferrite Bead Type TDK MMZ2012Y202B	Optional, (close to LIN connector)

Notes

- 41. Freescale does not assume liability, endorse, or want components from external manufactures that are referenced in circuit drawings or tables. While Freescale offers component recommendations in this configuration, it is the customer’s responsibility to validate their application.
- 42. Components are recommended to improve EMC and ESD performance.

PACKAGE DIMENSIONS

Important For the most current revision of the package, visit www.freescale.com and do a keyword search on the 98A drawing number: 98ASA10712D.

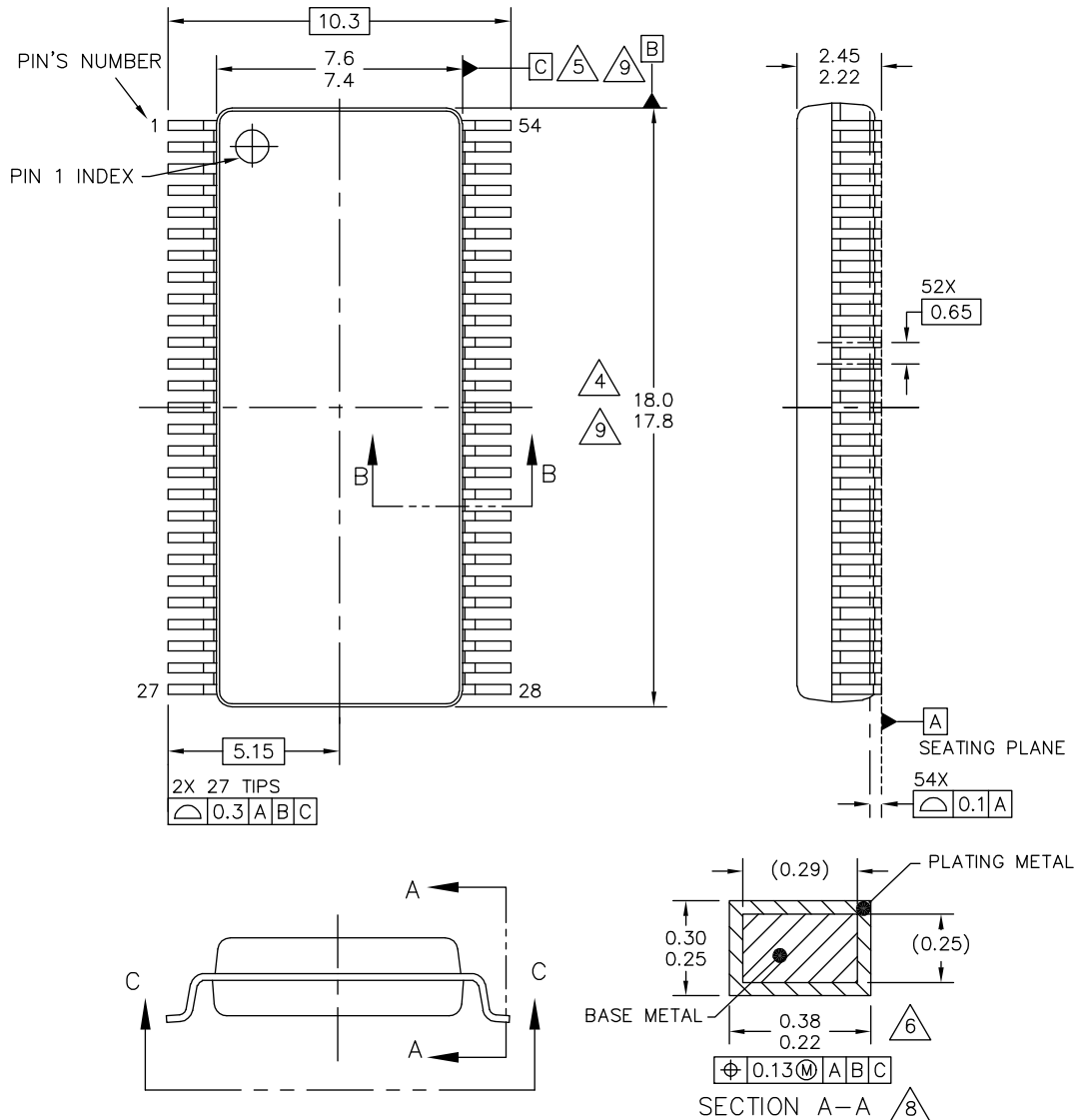

© FREESCALE SEMICONDUCTOR, INC. ALL RIGHTS RESERVED.	MECHANICAL OUTLINE		PRINT VERSION NOT TO SCALE	
	TITLE: 54LD SOIC W/B, 0.65 PITCH 4.5 X 9.8 EXPOSED PAD, CASE-OUTLINE		DOCUMENT NO: 98ASA10712D CASE NUMBER: 1823-01 STANDARD: NON-JEDEC	REV: 0 17 NOV 2005

EK SUFFIX (PB-FREE)
 54-PIN SOICW-EP
 98ASA10712D
 ISSUE 0

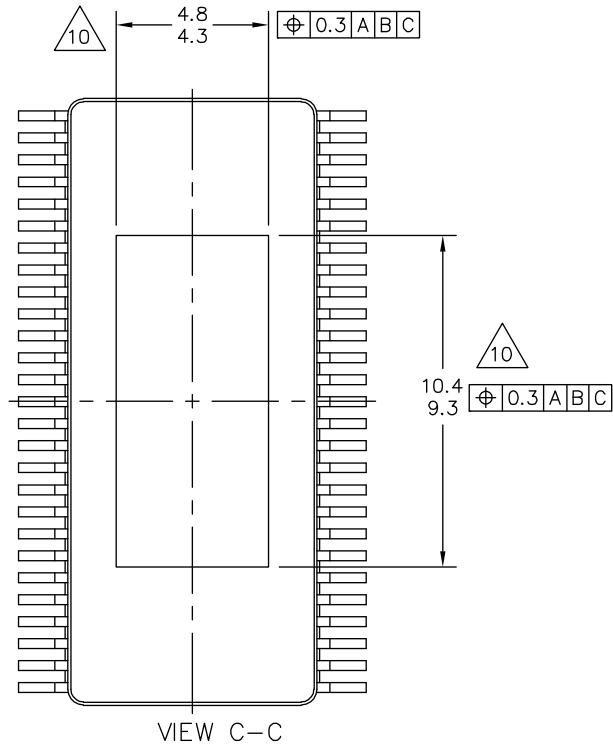
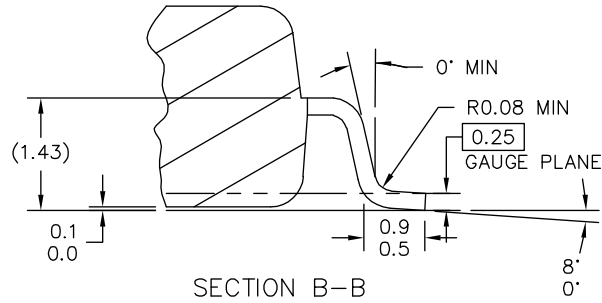

© FREESCALE SEMICONDUCTOR, INC. ALL RIGHTS RESERVED.	MECHANICAL OUTLINE	PRINT VERSION NOT TO SCALE	
TITLE: 54LD SOIC W/B, 0.65 PITCH 4.5 X 9.8 EXPOSED PAD, CASE-OUTLINE	DOCUMENT NO: 98ASA10712D	REV: 0	
	CASE NUMBER: 1823-01	17 NOV 2005	
	STANDARD: NON-JEDEC		

EK SUFFIX (PB-FREE)
54-PIN SOICW-EP
98ASA10712D
ISSUE 0

NOTES:

1. DIMENSIONS ARE IN MILLIMETERS.
2. DIMENSIONING AND TOLERANCING PER ASME Y14.5M-1994.
3. DATUMS B AND C TO BE DETERMINED AT THE PLANE WHERE THE BOTTOM OF THE LEADS EXIT THE PLASTIC BODY.
4. THIS DIMENSION DOES NOT INCLUDE MOLD FLASH, PROTRUSION OR GATE BURRS. MOLD FLASH, PROTRUSION OR GATE BURRS SHALL NOT EXCEED 0.15 MM PER SIDE. THIS DIMENSION IS DETERMINED AT THE PLANE WHERE THE BOTTOM OF THE LEADS EXIT THE PLASTIC BODY.
5. THIS DIMENSION DOES NOT INCLUDE INTER-LEAD FLASH OR PROTRUSIONS. INTER-LEAD FLASH AND PROTRUSIONS SHALL NOT EXCEED 0.25 MM PER SIDE. THIS DIMENSION IS DETERMINED AT THE PLANE WHERE THE BOTTOM OF THE LEADS EXIT THE PLASTIC BODY.
6. THIS DIMENSION DOES NOT INCLUDE DAMBAR PROTRUSION. ALLOWABLE DAMBAR PROTRUSION SHALL NOT CAUSE THE LEAD WIDTH TO EXCEED 0.46 mm. DAMBAR CANNOT BE LOCATED ON THE LOWER RADIUS OR THE FOOT. MINIMUM SPACE BETWEEN PROTRUSION AND ADJACENT LEAD SHALL NOT BE LESS THAN 0.07 mm.
7. EXACT SHAPE OF EACH CORNER IS OPTIONAL.
8. THESE DIMENSIONS APPLY TO THE FLAT SECTION OF THE LEAD BETWEEN 0.1 mm AND 0.3 mm FROM THE LEAD TIP.
9. THE PACKAGE TOP MAY BE SMALLER THAN THE PACKAGE BOTTOM. THIS DIMENSION IS DETERMINED AT THE OUTERMOST EXTREMES OF THE PLASTIC BODY EXCLUSIVE OF MOLD FLASH, TIE BAR BURRS, GATE BURRS AND INTER-LEAD FLASH, BUT INCLUDING ANY MISMATCH BETWEEN THE TOP AND BOTTOM OF THE PLASTIC BODY.
10. THESE DIMENSIONS DEFINE THE PRIMARY SOLDERABLE SURFACE AREA.

© FREESCALE SEMICONDUCTOR, INC. ALL RIGHTS RESERVED.	MECHANICAL OUTLINE	PRINT VERSION NOT TO SCALE	
TITLE: 54LD SOIC W/B, 0.65 PITCH 4.5 X 9.8 EXPOSED PAD, CASE-OUTLINE	DOCUMENT NO: 98ASA10712D	REV: 0	
	CASE NUMBER: 1823-01	17 NOV 2005	
	STANDARD: NON-JEDEC		

EK SUFFIX (PB-FREE)
54-PIN SOICW-EP
98ASA10712D
ISSUE 0

ADDITIONAL INFORMATION

THERMAL ADDENDUM (REV 1.0)

INTEGRATED QUAD H-BRIDGE AND TRIPLE HIGH-SIDE DRIVER WITH EMBEDDED MCU AND LIN FOR MIRROR

Introduction

This thermal addendum is provided as a supplement to the MM908E621 technical data sheet. The addendum provides thermal performance information that may be critical in the design and development of system applications. All electrical, application and packaging information is provided in the data sheet.

Package and Thermal Considerations

This MM908E621 is a dual die package. There are two heat sources in the package independently heating with P_1 and P_2 . This results in two junction temperatures, T_{J1} and T_{J2} , and a thermal resistance matrix with $R_{\theta JA mn}$.

For $m, n = 1$, $R_{\theta JA 11}$ is the thermal resistance from Junction 1 to the reference temperature while only heat source 1 is heating with P_1 .

For $m = 1, n = 2$, $R_{\theta JA 12}$ is the thermal resistance from Junction 1 to the reference temperature while heat source 2 is heating with P_2 . This applies to $R_{\theta J 21}$ and $R_{\theta J 22}$, respectively.

$$\begin{Bmatrix} T_{J1} \\ T_{J2} \end{Bmatrix} = \begin{bmatrix} R_{\theta JA 11} & R_{\theta JA 12} \\ R_{\theta JA 21} & R_{\theta JA 22} \end{bmatrix} \cdot \begin{Bmatrix} P_1 \\ P_2 \end{Bmatrix}$$

The stated values are solely for a thermal performance comparison of one package to another in a standardized environment. This methodology is not meant to and will not predict the performance of a package in an application-specific environment. Stated values were obtained by measurement and simulation according to the standards listed below.

Standards

Table 22. Thermal Performance Comparison

Thermal Resistance	1 = Power Chip, 2 = Logic Chip [°C/W]		
	$m = 1, n = 1$	$m = 1, n = 2$ $m = 2, n = 1$	$m = 2, n = 2$
$R_{\theta JA mn}^{(1)(2)}$	23	20	24
$R_{\theta JB mn}^{(2)(3)}$	9.0	6.0	10
$R_{\theta JA mn}^{(1)(4)}$	52	47	52
$R_{\theta JC mn}^{(5)}$	1.0	0	2.0

Notes:

- Per JEDEC JESD51-2 at natural convection, still air condition.
- 2s2p thermal test board per JEDEC JESD51-7 and JESD51-5.
- Per JEDEC JESD51-8, with the board temperature on the center trace near the power outputs.
- Single layer thermal test board per JEDEC JESD51-3 and JESD51-5.
- Thermal resistance between the die junction and the exposed pad, "infinite" heat sink attached to exposed pad.

908E621

54-PIN
SOICW-EP



98ASA10712D
54-PIN SOICW-EP

Note For package dimensions, refer to the 908E621 device datasheet.

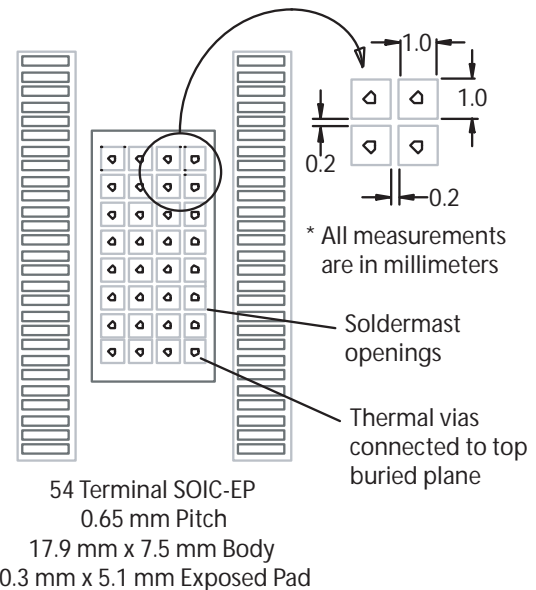

Figure 34. Thermal Land Pattern for Direct Thermal Attachment Per JEDEC JESD51-5

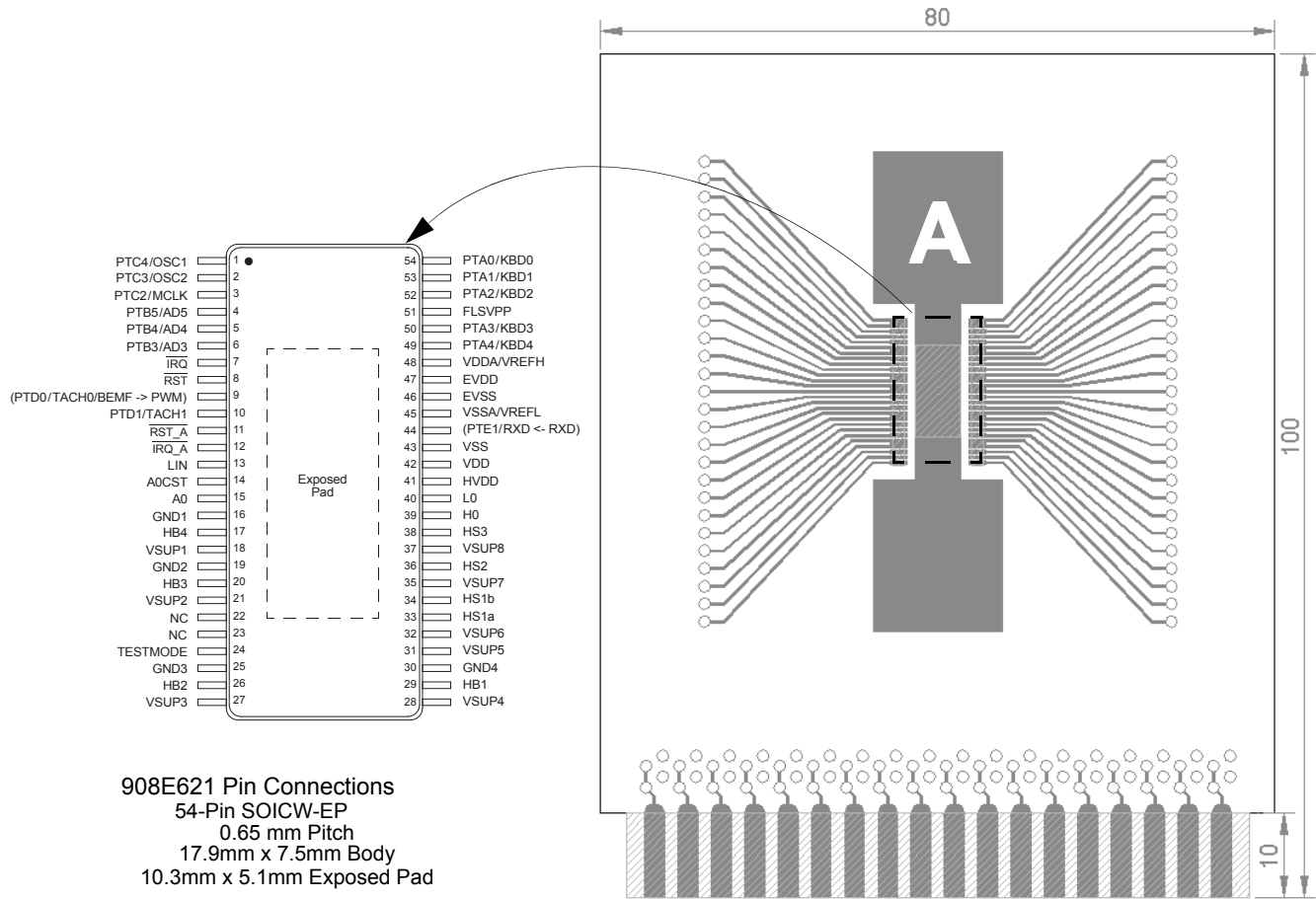

Figure 35. Thermal Test Board

Device on Thermal Test Board

- Material:** Single layer printed circuit board
FR4, 1.6 mm thickness
Cu traces, 0.07 mm thickness
- Outline:** 80 mm x 100 mm board area,
including edge connector for
thermal testing
- Area A:** Cu heat-spreading areas on board
surface
- Ambient Conditions:** Natural convection, still air

Table 23. Thermal Resistance Performance

Thermal Resistance	Area A (mm ²)	1 = Power Chip, 2 = Logic Chip (°C/W)		
		m = 1, n = 1	m = 1, n = 2 m = 2, n = 1	m = 2, n = 2
R _{θJA} <i>mn</i>	0	53	48	53
	300	39	34	38
	600	35	30	34
R _{θJS} <i>mn</i>	0	21	16	20
	300	15	11	15
	600	14	9.0	13

R_{θJA} is the thermal resistance between die junction and ambient air.

R_{θJS}*mn* is the thermal resistance between die junction and the reference location on the board surface near a center lead of the package. This device is a dual die package. Index *m* indicates the die that is heated. Index *n* refers to the number of the die where the junction temperature is sensed.

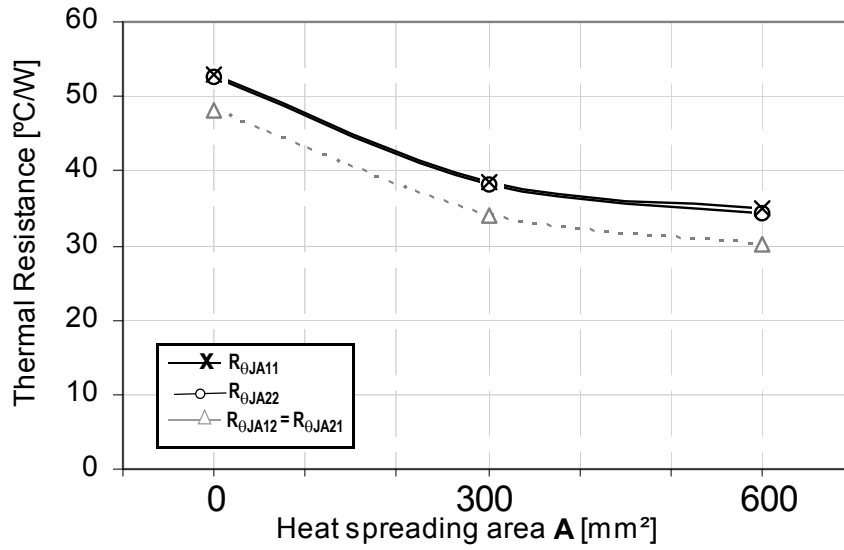

Figure 36. Device on Thermal Test Board R_{θJA}

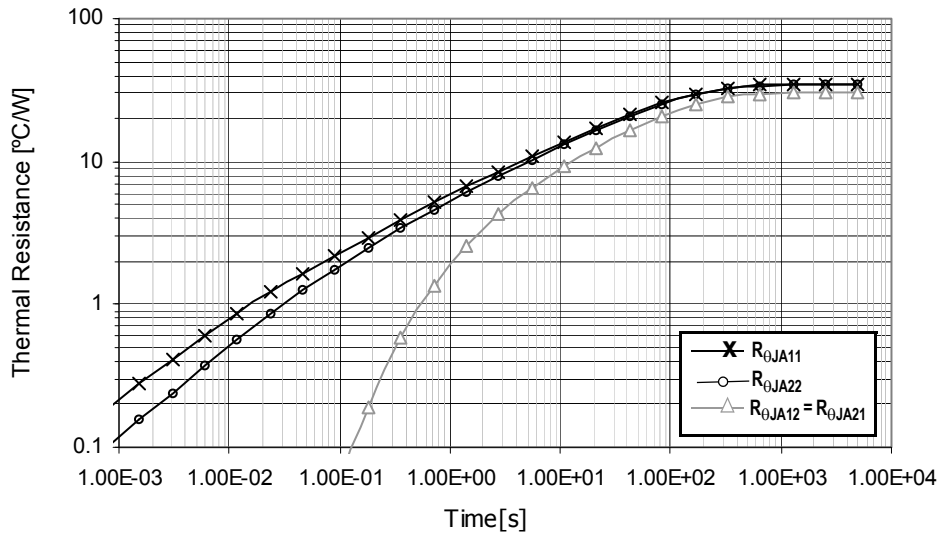

Figure 37. Transient Thermal Resistance R_{θJA} (1.0 W Step Response)
 Device on Thermal Test Board Area A = 600 (mm²)

REVISION HISTORY

REVISION	DATE	DESCRIPTION OF CHANGES
3.0	2/2007	<ul style="list-style-type: none"> • Implemented Revision History page • Changed Table 3, Statistic Electrical Characteristics, Hall-Effect Sensor Input H0 - 2pin Hall Sensor Input Mode (H0MS = 1), Sense Current Hysteresis on page 13 from a Minimum of 800 to 600 and Typical from 1100 to none. • Removed "Advance" watermark and updated to final Data Sheet. • Removed Peak Package Reflow Temperature During Reflow (solder reflow) parameter from Electrical Characteristics on page 6. Added note with instructions from www.freescale.com.
4.0	6/2007	<ul style="list-style-type: none"> • Updated to Final by removing "Advance Information" from page 1.
5.0	6/2008	<ul style="list-style-type: none"> • Changed STOP Mode Total Output Current on page 9 from 850 to 1100μA • Changed Sense Current Hysteresis on page 13 from 800 to 650μA • Changed Normal Request Timeout on page 15 from 124 to 150ms • Updated Freescale form and style to the current format • Updated package drawing • Added Functional Internal Block Description section
6.0	4/2012	<ul style="list-style-type: none"> • Added MM908E621ACPEK/R2 to the ordering information. • Removed MM908E621ACDWB/R2 from the data sheet • Updated Freescale form and style to the current format

How to Reach Us:

Home Page:
freescale.com

Web Support:
freescale.com/support

Information in this document is provided solely to enable system and software implementers to use Freescale products. There are no express or implied copyright licenses granted hereunder to design or fabricate any integrated circuits on the information in this document.

Freescale reserves the right to make changes without further notice to any products herein. Freescale makes no warranty, representation, or guarantee regarding the suitability of its products for any particular purpose, nor does Freescale assume any liability arising out of the application or use of any product or circuit, and specifically disclaims any and all liability, including without limitation consequential or incidental damages. "Typical" parameters that may be provided in Freescale data sheets and/or specifications can and do vary in different applications, and actual performance may vary over time. All operating parameters, including "typicals," must be validated for each customer application by customer's technical experts. Freescale does not convey any license under its patent rights nor the rights of others. Freescale sells products pursuant to standard terms and conditions of sale, which can be found at the following address: <http://www.reg.net/v2/webservices/Freescale/Docs/TermsandConditions.htm>

Freescale, the Freescale logo, AltiVec, C-5, CodeTest, CodeWarrior, ColdFire, C-Ware, Energy Efficient Solutions logo, mobileGT, PowerQUICC, QorIQ, Qorivva, StarCore, and Symphony are trademarks of Freescale Semiconductor, Inc., Reg. U.S. Pat. & Tm. Off. Airfast, BeeKit, BeeStack, ColdFire+, CoreNet, Flexis, MagniV, MXC, Platform in a Package, Processor expert, QorIQ Qonverge, QUICC Engine, Ready Play, SMARTMOS, TurboLink, Vybrid, and Xtrinsic are trademarks of Freescale Semiconductor, Inc. All other product or service names are the property of their respective owners.

© 2012 Freescale Semiconductor, Inc.