

Protected High Side Power Switch with Transient Suppression

March 1995

Features

- $\pm 90V$ Transient Suppression
- 4V to 16V Operating Voltage
- 1A Current Load Capability
- Low Input-Output Voltage Drop With Controlled Saturation Detector for
 - Fast Low Current Turn-OFF
 - Reduced No-Load Idle Current
- Over-Voltage Shutdown Protection
- Short Circuit Current Limiting
- Over-Temperature Limiting Protected
- Thermal Limiting at $T_J = +150^\circ C$
- $-40^\circ C$ to $+125^\circ C$ Operating Temperature Range

Applications

- Electronic Circuit Breaker
- Transient Suppressor
- Over-Voltage Monitor
- High Side Driver Switch for
 - Relays
 - Solenoids
 - Heaters
 - Motors
 - Lamps

Description

The HIP1090 is a Protected Power Interface Switch designed to suppress potentially damaging over-voltage transients with peak voltage source inputs ranging up to $\pm 90V$ in amplitude. It is designed to be operated in a 'hard-wired' pass-thru mode or as a high side power switch which controls the current flow through a PNP pass transistor of the IC. In either mode The HIP1090 has a low saturated forward voltage drop. The protected load circuit is connected to the output of the IC. As such, the HIP1090 operates as a transient suppressor where the PNP drive transistor is switched off when V_{IN} is greater than the Over-Voltage Shutdown range of 16V to 19V. Shutdown also occurs when V_{IN} is less than the forward turn-on threshold of approximately 2.5V, including the negative voltage range.

The merits of transient suppression depend on the required integrity of the applications load elements. Instrument panel signal warning lights for critical functions such as over-temperature or low fluid levels can be protected by the HIP1090 against high level transient voltages and double battery conditions that may potentially cause bulb burnouts. The HIP1090 may be used to protect the power supplies of small signal or logic circuits with voltages ranging from 4V to 16V, effectively blocking higher peak voltages.

The HIP1090 has internal current limiting protection in the range of 1A to 2A for short circuit to ground conditions and thermal shutdown protection when the junction temperature is greater than $150^\circ C$. It is capable of driving resistive, inductive or lamp loads (such as lamps No. 168 or 194) with minimum risk of damage under harsh environmental stress conditions. The HIP1090 is supplied in a 3 lead TO-220AB package.

Ordering Information

PART NUMBER	TEMPERATURE RANGE	PACKAGE
HIP1090AS	$-40^\circ C$ to $+125^\circ C$	TO-220AB SIP

Pinout

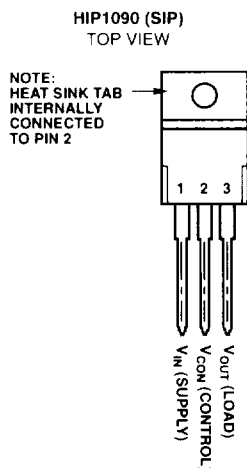

Functional Block Diagram

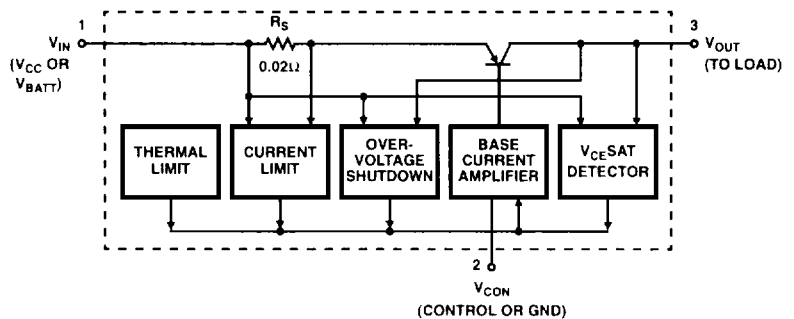

CAUTION These devices are sensitive to electrostatic discharge. Users should follow proper I.C. Handling Procedures.

Copyright © Harris Corporation 1995

File Number **3398.3**

Specifications HIP1090

Absolute Maximum Ratings

Input (Supply) Voltage, V_{IN} (Control Pin Reference) $\pm 24V$
 Transient Max Voltage, V_{IN} (15ms) $\pm 90V$
 Load Current, I_{OUT} Short Circuit Protected

Thermal Information

Thermal Resistance θ_{JA} θ_{JC}
 Plastic SIP Package $50^{\circ}C/W$ $4^{\circ}C/W$
 Maximum Power Dissipation, (Note 4)
 At $T_A = +105^{\circ}C$, Infinite Heat Sink $11.25W$
 Junction Temperature $+150^{\circ}C$
 Ambient Temperature Range $-40^{\circ}C$ to $+125^{\circ}C$
 Storage Temperature Range $-40^{\circ}C$ to $+150^{\circ}C$
 Lead Temperature (Soldering During) $\pm 265^{\circ}C$
 $1/16 \pm 1/32$ inch ($1.59 \pm 0.79mm$) from case for 10s maximum

CAUTION: Stresses above those listed in "Absolute Maximum Ratings" may cause permanent damage to the device. This is a stress only rating and operation of the device at these or any other conditions above those indicated in the operational sections of this specification is not implied.

Electrical Specifications $T_A = -40^{\circ}C$ to $+125^{\circ}C$; $V_{IN} = 4V$ to $16V$; $V_{CON} = GND$ or $0V$. Unless Otherwise Specified

PARAMETERS	SYMBOL	TEST CONDITIONS	MIN	TYP	MAX	UNITS
Input (Supply) Voltage Operating Range	V_{IN}	(Note 1); Also, See Figure 4 for Expanding V_{IN} Range	4	-	16	V
Input Voltage Threshold for Forward Turn-On to Load	V_{THD}	Load = $1k\Omega$	-	2.5	-	V
Input Voltage for Output Shutdown	V_{SHSD}	(Note 2)	16	-	19	V
Output Shutdown Leakage	I_{LEAK1}	$V_{IN} = 19V$ and $24V$; Load = $1k\Omega$	-	-	100	μA
Output Cutoff Leakage	I_{LEAK2}	$V_{IN} = 16V$; Control Open; Load = $1k\Omega$	-	1	-	μA
Thermal Shutdown Temperature	T_{SD}		-	150	-	$^{\circ}C$
Maximum Output Transient Pulse Current	$I_{OUT(Tran)}$	$V_{IN} = \pm 90V$ for 15ms, $V_{OUT} = 14V$	-20	-	+20	mA
Maximum Control Transient Pulse Current	$I_{CON(Tran)}$	$V_{IN} = \pm 90V$ for 15ms, $V_{OUT} = 14V$	-50	-	+50	mA
Short Circuit Current	I_{SC}		1	-	2	A
Input-to-Output Voltage Drop		$V_{IN} = 4V$, $I_{OUT} = 175mA$	-	-	0.25	V
		$V_{IN} = 9V$, $I_{OUT} = 500mA$	-	-	0.65	V
		$V_{IN} = 16V$, $I_{OUT} = 800mA$	-	-	1.05	V
		$V_{IN} = 16V$, $I_{OUT} = 1A$	-	0.8	-	V
Control Current	I_{CON}	$V_{IN} = 16V$, $I_{OUT} = 100mA$	-	-	25	mA
		$V_{IN} = 16V$, $I_{OUT} = 800mA$	-	-	50	mA
		$V_{IN} = 16V$, $I_{OUT} = 1A$	-	50	-	mA
Turn ON (Rise Time); "Pass-Thru" Mode	t_{ON}	Switch V_{IN} $0V(GND)$ to $5.5V$; Measure V_{OUT} (to 90%); Load = $1k\Omega$ (Note 3)	-	-	20	μs
Turn OFF (Fall Time); "Pass-Thru" Mode	t_{OFF}	Switch V_{IN} $5.5V$ to $0V(GND)$; Measure V_{OUT} (to 90%); Load = $1k\Omega$ (Note 3)	-	-	20	μs
Turn ON (Rise Time); High Pass Switch Mode	t_{ON}	See Figure 3 and Figure 4 (Note 3)	-	15	-	μs
Turn OFF (Fall Time); High Pass Switch Mode	t_{OFF}	See Figure 3 and Figure 4 (Note 3)	-	15	-	μs

NOTES:

- The Input Operating Voltage is not limited by the threshold of Shutdown. The V_{IN} voltage may range to $\pm 24V$ while the normal functional switching range is typically $+2.5V$ to $+17.5V$ (reference to V_{CON}).
- The Output Drive is switched-off when the Input voltage(Supply pin), referenced to the Control pin exceeds the threshold shutdown VSHSD or the input voltage is less than the forward turn-on threshold (Including negative voltages within the transient peak ratings).
- T_{ON} and T_{OFF} times include Prop Delay and Rise/Fall time
- The worst case thermal resistance, θ_{JC} for the SIP TO-220 is $4^{\circ}C/W$. The calculation for dissipation and junction temperature rise due to dissipation is:

$$P_D = (V_{IN} - V_{OUT}) \times (V_{IN}) \times (I_{CON})$$

$$T_J = T_{AMBIENT} + (P_D) \times (\theta_{JC}) \text{ for an infinite Heat Sink.}$$

Derating from $150^{\circ}C$ is based on the reciprocal of thermal resistance, $\theta_{JC} + \theta_{HS}$. For example: Where $\theta_{JC} = 4^{\circ}C/W$ and given $\theta_{HS} = 6^{\circ}C/W$ as the thermal resistance of an external Heat Sink, the junction-to-air thermal resistance, $\theta_{JA} = 10^{\circ}C/W$. Therefore, for the maximum allowed dissipation, derate $0.1W/^{\circ}C$ for each degree from T_{AMB} to the maximum rated junction temperature of $150^{\circ}C$. If $T_{AMB} = 100^{\circ}C$, the maximum P_D is $(150 - 100) \times 0.1W/^{\circ}C = 5W$.

Applications

The HIP1090 may be used as a "hard-wired pass-thru" device to protect the load from source voltage transients or may be used as an active high side power interface switch with up to 1A of Load current capability. An ON state condition of $(V_{IN} - 4V) \leq V_{CON} < (V_{IN} - 16V)$ is the normal range required to activate the high pass switch, allowing the supply source to conduct through the PNP to the load. When the control terminal, V_{CON} is open, the high pass switch is open (no conduction). Figure 2 shows an HIP1090 application example with a switch in the V_{CON} terminal. In comparison to the hard wired circuit of Figure 1 where pin 2 is fixed at ground, pin 2 in the circuit of Figure 2 is switched from open to ground to turn-ON the high pass switch. Used

in this mode, the HIP1090 is both an effective transient suppressor and a high pass switch. The switch in the V_{CON} terminal may be active or passive and conducts typically less than 50mA of current. The HIP1090 used in the controlled switching mode retains all of the protected features of the device. In either circuit the output capacitor may be increased in size to hold charge longer during transient interruptions at the input. The charge duration for larger capacitors or for lamp loads is tolerated because of the internal short circuit current limiting protection. Sustained short circuits may cause the junction temperature to reach the thermal shutdown temperature (150°C).

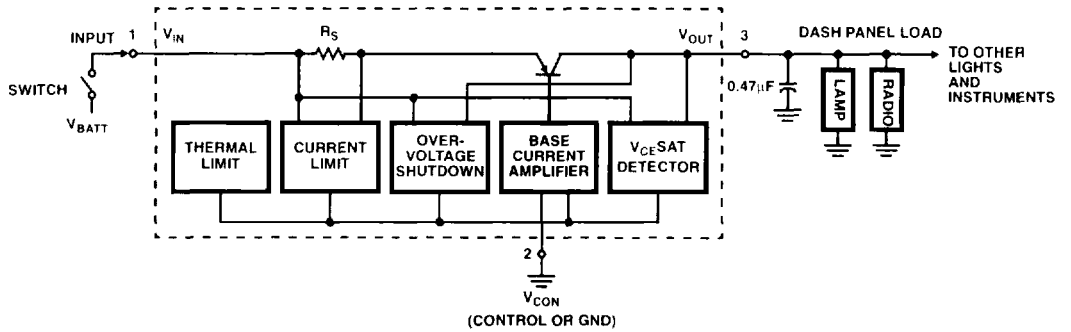

FIGURE 1. TYPICAL APPLICATION OF THE HIP1090 AS A TRANSIENT SUPPRESSOR IN A "PASS-THRU" MODE

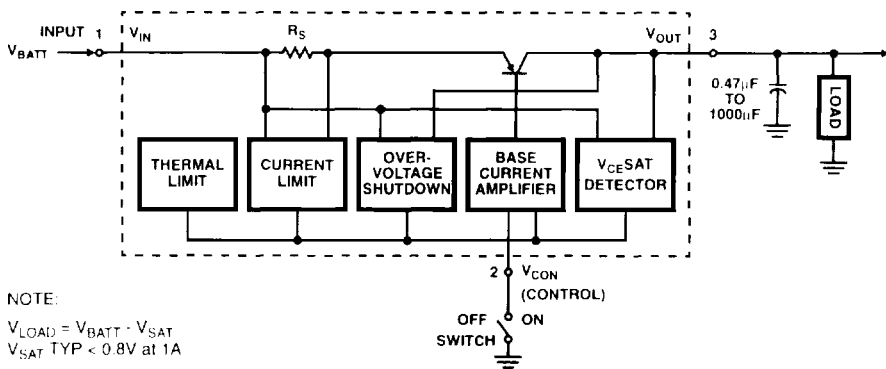

FIGURE 2. TYPICAL APPLICATIONS OF THE HIP1090 AS A TRANSIENT SUPPRESSOR IN A HIGH PASS SWITCH MODE

Figure 3 shows the pulsed output switching characteristics of the HIP1090 as a high side driver. A small delay step is noted on the rising edge due to the hold-off of a $V_{CE\text{SAT}}$ detector circuit. The $V_{CE\text{SAT}}$ circuit senses the saturation level of the PNP pass transistor and controls the drive as a ratio of load current. As the load current is reduced, the drive current to the output transistor is reduced. Under low current operation, the saturation level is controlled and the turn-OFF switching time is much faster. The control switching element is shown as a 2N5320 NPN transistor but may be any open collector or MOS gate. A pull-up resistor of $2k\Omega$ is used for a slight improvement in the turnoff fall time but is not an essential requirement. The V_{CON} terminal may be controlled with a mechanical switch or may be controlled from any driver output that can sink the worst case condition of pin 2 current, I_{CON} when the output load current is increased to 1A (typically 50mA).

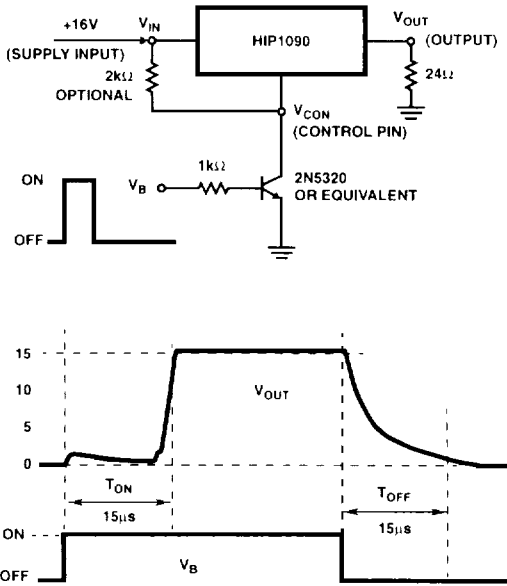

FIGURE 3. TYPICAL ON-OFF SWITCHING CHARACTERISTIC OF THE HIP1090 USING AN NPN TRANSISTOR TO SWITCH THE V_{CON} INPUT TERMINAL

The circuit of Figure 4 shows how the HIP1090 transient suppression voltage shutdown threshold may be increased by using a zener diode from the V_{CON} terminal to the collector terminal of the transistor switch. The preferred method is to use a zener diode for a fixed level shift. While a resistor in place of the zener diode having the same voltage drop will work well, the parametric variation of the I_{CON} current will cause variations of the Over-Voltage Shutdown Threshold. In this circuit, a 10V zener provides a typical over-voltage threshold shift to $-27V$. The threshold for over-voltage shutdown is referenced to the $(V_{IN} - V_{CON})$ voltage difference.

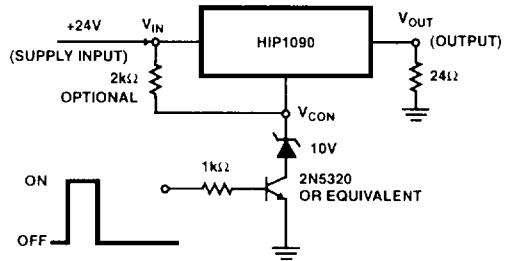

FIGURE 4. A TYPICAL APPLICATION CIRCUIT THAT USES A ZENER TO THE V_{CON} TRANSISTOR SWITCH TO RAISE THE OVER-VOLTAGE SHUTDOWN THRESHOLD

Also, it is important to note that high peak current values may be reached when driving nonlinear and inductive loads. The peak output current of the HIP1090 is self limiting in the 1A to 2A range to protect against short circuit conditions. Sustained high peak current may increase the junction temperature to 150°C and cause thermal shutdown. When this happens, the output current will fall off briefly before recovering, unless the over-temperature condition is sustained. Internally, both input and output over-voltage conditions are sensed to protect the circuit, making the high levels of transient voltage ratings possible. Sustained voltage ratings of $\pm 24\text{VDC}$ with transient ratings to $\pm 90\text{V}$ allow a wide variety of applications in high stress environments.

Except for the $V_{CE\text{SAT}}$ detector circuit, the HIP1090 is a higher current version of the CA3273 high side driver, which turns-on without the delayed step on the leading edge of the output pulse; switching with a typical T_{ON} time of $\sim 0.5\mu\text{s}$. The CA3273 has a higher transient suppression threshold.

Typical Performance Curves

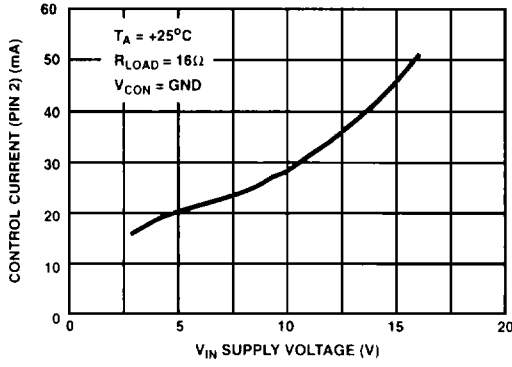

FIGURE 5. CONTROL (QUIESCENT) CURRENT CHARACTERISTIC WITH LOAD

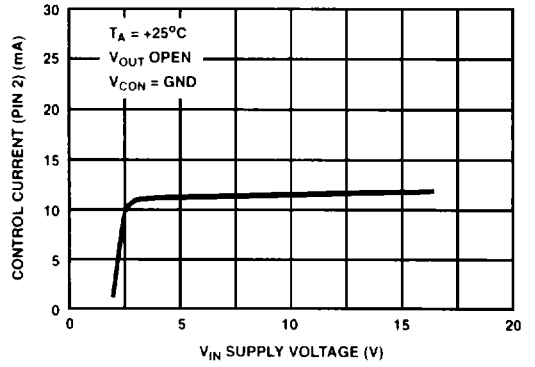

FIGURE 6. CONTROL (QUIESCENT) CURRENT CHARACTERISTIC WITH NO LOAD

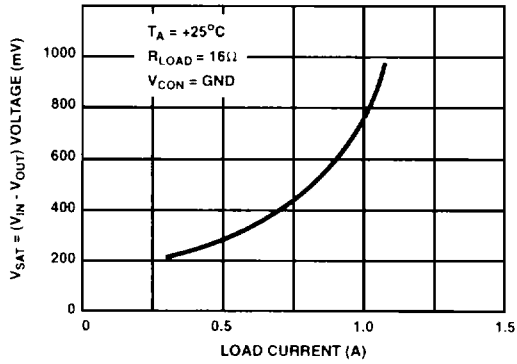
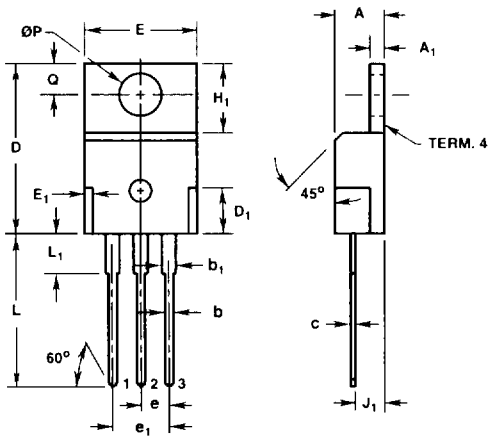

FIGURE 7. SATURATION (V_{IN} - V_{OUT}) CHARACTERISTIC

Packaging



Lead No. 1 - Gate
 Lead No. 2 - Collector
 Lead No. 3 - Emitter
 Mounting Flange - Collector

TO-220AB

3 LEAD JEDEC TO-220AB PLASTIC PACKAGE

SYMBOL	INCHES		MILLIMETERS		NOTES
	MIN	MAX	MIN	MAX	
A	0.170	0.180	4.32	4.57	-
A ₁	0.048	0.052	1.22	1.32	-
b	0.030	0.034	0.77	0.86	3, 4
b ₁	0.045	0.055	1.15	1.39	2, 3
c	0.014	0.019	0.36	0.48	2, 3, 4
D	0.590	0.610	14.99	15.49	-
D ₁	-	0.160	-	4.06	-
E	0.395	0.410	10.04	10.41	-
E ₁	-	0.030	-	0.76	-
e	0.100 TYP		2.54 TYP		5
e ₁	0.200 BSC		5.08 BSC		5
H ₁	0.235	0.255	5.97	6.47	-
J ₁	0.100	0.110	2.54	2.79	6
L	0.530	0.550	13.47	13.97	-
L ₁	0.130	0.150	3.31	3.81	2
ØP	0.149	0.153	3.79	3.88	-
Q	0.102	0.112	2.60	2.84	-

NOTES:

1. These dimensions are within allowable dimensions of Rev. J of JEDEC TO-220AB outline dated 3-24-87.
2. Lead dimension and finish uncontrolled in L₁.
3. Lead dimension (without solder)
4. Add typically 0.002 inches (0.05mm) for solder coating.
5. Position of lead to be measured 0.250 inches (6.35mm) from bottom of dimension D.
6. Position of lead to be measured 0.100 inches (2.54mm) from bottom of dimension D.
7. Controlling dimension: Inch.
8. Revision 1 dated 1-93.