

TJA1102A

100BASE-T1 dual/single PHY for automotive Ethernet

Rev. 1 — 7 June 2021

Product data sheet

1 General description

The TJA1102A is a 100BASE-T1-compliant dual-port Ethernet PHY optimized for automotive use cases such as gateways, IP camera links, radar modules, driver assistance systems and back-bone networks. The device provides 100 Mbit/s transmit and receive capability over two unshielded twisted-pair cables, supporting a cable length of up to at least 15 m. The TJA1102A has been designed for automotive robustness, while minimizing power consumption and system costs. For added flexibility, a single PHY version is available (TJA1102AS) in which one of the PHYs is disabled. Unless otherwise specified, all references in this document to TJA1102A encompass both the dual- and single-PHY variants.

The TJA1102A supports OPEN Alliance TC-10-compliant sleep and wake-up request forwarding, with an always-on power domain connected directly to the battery supply without the need for a dedicated voltage regulator.

2 Features and benefits

2.1 General

- Dual-port 100BASE-T1 PHY; single-port operation possible
- Single-port variant available
- MII- and RMII-compliant interfaces
- HVQFN 56-pin package (8 × 8 mm)

2.2 Optimized for automotive use cases

- Transmitter optimized for capacitive coupling to unshielded twisted-pair cable
- Adaptive receive equalizer optimized for automotive cable length of up to at least 15 m
- Enhanced integrated PAM-3 pulse shaping for low RF emissions
- EMC-optimized output driver strength for MII and RMII
- MDI pins meet class IV conducted emission limit as per OPEN Alliance EMC Specification 2.0
- MDI pins protected against ESD to ± 6 kV HBM and ± 6 kV IEC61000-4-2
- MDI pins protected against transients in automotive environment
- MDI pins do not need external filtering or ESD protection
- Automotive-grade temperature range from -40 °C to $+125$ °C
- Automotive product qualification in accordance with AEC-Q100
- Host-configurable MDI polarity
- Automated polarity detection and correction



2.3 Low-power mode

- OPEN Alliance TC-10-compliant sleep and wake-up forwarding
 - Robust remote wake-up detection via bus lines
 - Wake-up forwarding at PHY level (supporting global system wake-up)
- Inhibit output for voltage regulator control
- Dedicated PHY enable/disable input pin to minimize power consumption
- Local wake-up pin
- Wake-up via SMI-access

2.4 Diagnosis

- Signal Quality Indicator for real-time monitoring of link stability and transmitted data quality
- Diagnosis of cable errors (shorts and opens)
- Gap-free supply undervoltage detection with fail-silent behavior
- Internal, external and remote loopback modes

2.5 Miscellaneous

- Internal reverse MII mode for repeater operation
- On-chip regulators to provide 3.3 V single-supply operation
- Supports optional 1.8 V external supply for digital core
- On-chip termination resistors for the differential cable pair
- Jumbo frame support up to 16 kB

3 Ordering information

Table 1. Ordering information

Type number	Package		
	Name	Description	Version
TJA1102AHN ^[1]	HVQFN56	plastic thermal enhanced very thin quad flat package; no leads; 56 terminals; body 8 × 8 × 0.85 mm	SOT684-13
TJA1102AHN/S ^[2]			

[1] Dual PHY.
 [2] Single PHY.

4 Block diagram

A block diagram of the TJA1102A is shown in [Figure 1](#). The 100BASE-T1 sections contain the functional blocks specified in the 100BASE-T1 standard that make up the Physical Coding Sublayer (PCS) and the Physical Medium Attachment (PMA) layer for both the transmit and receive signal paths. The MII/RMII interface (including the Serial Management Interface (SMI)) conforms to IEEE 802.3 clause 22.

Additional blocks are defined for mode control, register configuration, interrupt control, system configuration, reset control, local wake-up, remote wake-up, undervoltage detection and configuration control. A number of power-supply-related functional blocks are defined: an internal 1.8 V regulator for the digital core, a Very Low Power (VLP) supply for Sleep mode, the reset circuit, supply monitoring and inhibit control.

The clock signals needed for the operation of the PHY are generated in the PLL block, derived from an external crystal or an oscillator input signal.

Pin strapping allows a number of default PHY settings (e.g. Master or Slave configuration) to be hardware-configured at power-up.

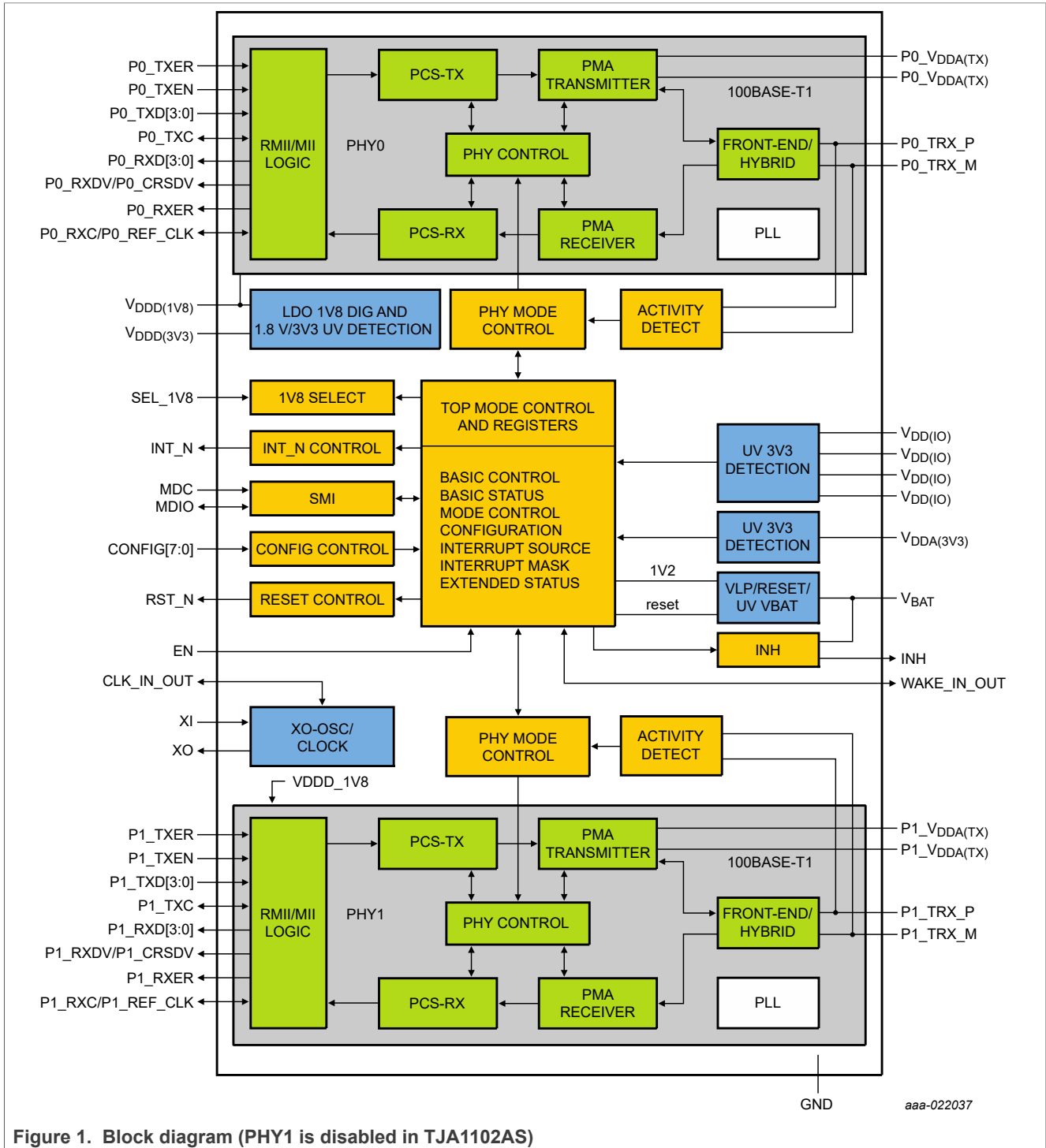

Figure 1. Block diagram (PHY1 is disabled in TJA1102AS)

5 Pinning information

5.1 TJA1102A pinning

The pin configuration of the TJA1102A dual PHY is shown in Figure 2. Separate interface and supply pins are provided for each PHY block. The SMI is shared between the two PHYs. Since 100BASE-T1 allows for full-duplex bidirectional communication, the standard MII signals COL and CRS are not needed.

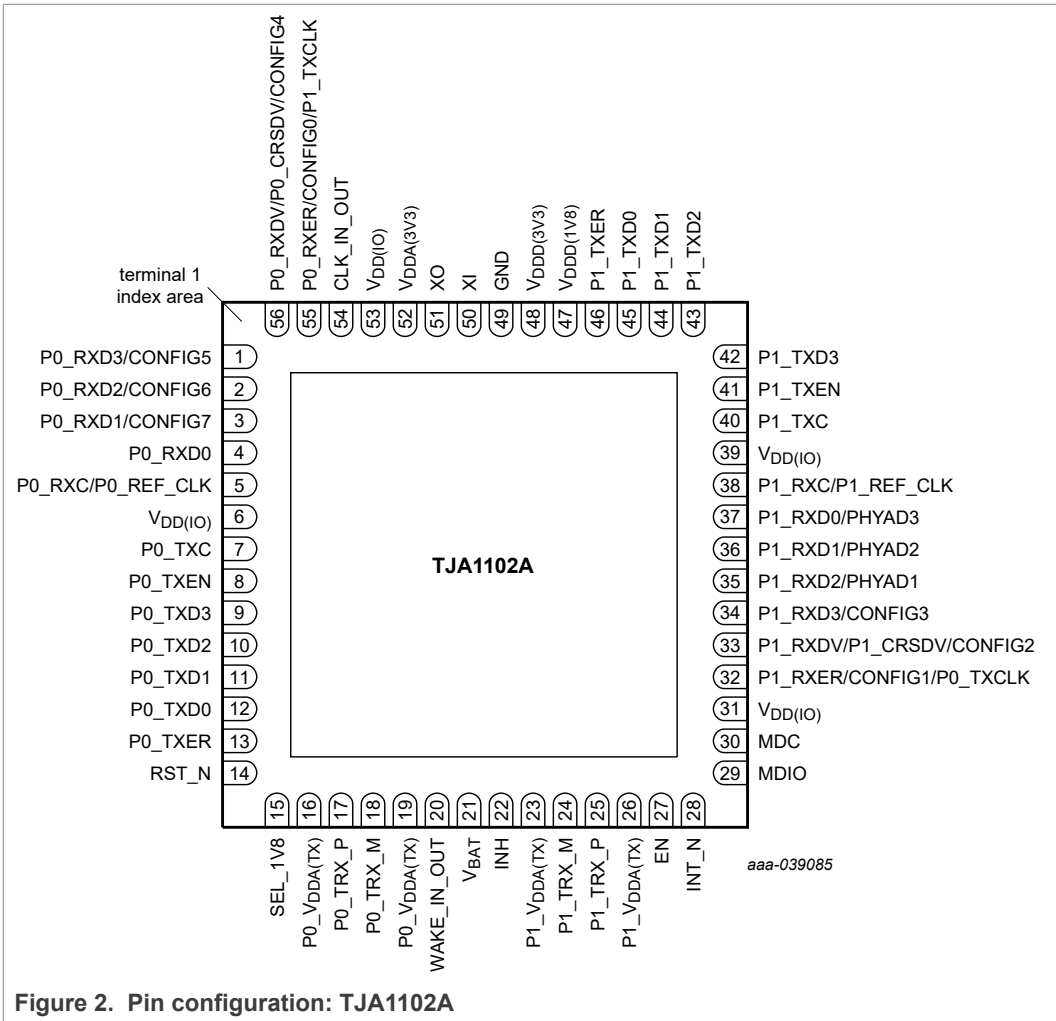

Figure 2. Pin configuration: TJA1102A

Table 2. TJA102A pin description

Symbol	Pin	Type ^[1]	Description
P0_RXD3	1	O	P0 MII mode: receive data output, bit 3 of RXD[3:0] nibble
CONFIG5	1	I	pin strapping configuration input 5
P0_RXD2	2	O	P0 MII mode: receive data output, bit 2 of RXD[3:0] nibble
CONFIG6	2	I	pin strapping configuration input 6

Table 2. TJA102A pin description...continued

Symbol	Pin	Type ^[1]	Description
P0_RXD1	3	O	P0 MII mode: receive data output, bit 1 of RXD[3:0] nibble P0 RMII mode: receive data output, bit 1 of RXD[1:0] nibble
CONFIG7	3	I	pin strapping configuration input 7
P0_RXD0	4	O	P0 MII mode: receive data output, bit 0 of RXD[3:0] nibble P0 RMII mode: receive data output, bit 0 of RXD[1:0] nibble
P0_RXC	5	I	P0 MII reverse mode: external 25 MHz clock input
		O	P0 MII mode: 25 MHz receive clock output
P0_REF_CLK	5	I	P0 RMII mode: interface reference clock input (50 MHz external oscillator)
		O	P0 RMII mode: interface reference clock output (25 MHz crystal at PHY or 25 MHz clock at input of pin CLK_IN_OUT)
V _{DD(IO)} ^[2]	6	P	3.3 V digital I/O supply voltage
P0_TXC	7	I	P0 MII reverse mode: external 25 MHz transmit clock input
		O	P0 MII mode: 25 MHz transmit clock output
P0_TXEN	8	I	P0 MII/RMII mode: transmit enable input (active-HIGH, weak pull-down)
P0_TXD3	9	I	P0 MII mode: transmit data input, bit 3 of TXD[3:0] nibble (weak pull-down)
P0_TXD2	10	I	P0 MII mode: transmit data input, bit 2 of TXD[3:0] nibble (weak pull-down)
P0_TXD1	11	I	P0 MII mode: transmit data input, bit 1 of TXD[3:0] nibble (weak pull-down) P0 RMII mode: transmit data input, bit 1 of TXD[1:0] nibble (weak pull-down)
		I	P0 MII mode: transmit data input, bit 0 of TXD[3:0] nibble (weak pull-down) P0 RMII mode: transmit data input, bit 0 of TXD[1:0] nibble (weak pull-down)
P0_TXD0	12	I	P0 MII mode: transmit data input, bit 0 of TXD[3:0] nibble (weak pull-down) P0 RMII mode: transmit data input, bit 0 of TXD[1:0] nibble (weak pull-down)
P0_TXER	13	I	P0 MII/RMII: transmit error input (weak pull-down)
RST_N	14	I	reset input (active-LOW; weak pull-up)
SEL_1V8	15	I	1.8 V LDO mode selection (external or internal; weak pull-down)
P0_V _{DDA(TX)} ^[3]	16	P	3.3 V analog supply voltage for the P0 transmitter
P0_TRX_P	17	AIO	+ terminal for P0 transmit/receive signal
P0_TRX_M	18	AIO	- terminal for P0 transmit/receive signal
P0_V _{DDA(TX)} ^[3]	19	P	3.3 V analog supply voltage for the P0 transmitter
WAKE_IN_OUT	20	AIO	local/forwarding wake-up input/output (configurable)
V _{BAT}	21	P	battery supply voltage
INH	22	AO	inhibit output for voltage regulator control (V _{BAT} -related, active-HIGH)
P1_V _{DDA(TX)} ^[4]	23	P	3.3 V analog supply voltage for the P1 transmitter
P1_TRX_M	24	AIO	- terminal for P1 transmit/receive signal
P1_TRX_P	25	AIO	+ terminal for P1 transmit/receive signal
P1_V _{DDA(TX)} ^[4]	26	P	3.3 V analog supply voltage for the P1 transmitter
EN	27	I	PHY enable input (active-HIGH, weak pull-down)
INT_N	28	O	interrupt output (active-LOW, open-drain output, level-based)
MDIO	29	IO	SMI data I/O (weak pull-up)
MDC	30	I	SMI clock input (weak pull-down)

Table 2. TJA102A pin description...continued

Symbol	Pin	Type ^[1]	Description
V _{DD(I/O)} ^[2]	31	P	3.3 V digital I/O supply voltage
P1_RXER	32	O	P1 MII/RMII receive error output
CONFIG1	32	I	pin strapping configuration input 1
P0_TXCLK	32	O	P0 transmit clock output in test mode and during slave jitter test
P1_RXDV	33	O	P1 MII receive data valid output
P1_CRSDV	33	O	P1 RMII carrier sense/receive data valid output
CONFIG2	33	I	pin strapping configuration input 2
P1_RXD3	34	O	P1 MII mode: receive data output, bit 3 of RXD[3:0] nibble
CONFIG3	34	I	pin strapping configuration input 3
P1_RXD2	35	O	P1 MII mode: receive data output, bit 2 of RXD[3:0] nibble
PHYAD1	35	I	pin strapping configuration input for bit 1 of the PHY address used for the SMI address/ Cipher scrambler
P1_RXD1	36	O	P1 MII mode: receive data output, bit 1 of RXD[3:0] nibble P1 RMII mode: receive data output, bit 1 of RXD[1:0] nibble
PHYAD2	36	I	pin strapping configuration input for bit 2 of the PHY address used for the SMI address/ Cipher scrambler
P1_RXD0	37	O	P1 MII mode: receive data output, bit 0 of RXD[3:0] nibble P1 RMII mode: receive data output, bit 0 of RXD[1:0] nibble
PHYAD3	37	I	pin strapping configuration input for bit 3 of the PHY address used for the SMI address/ Cipher scrambler
P1_RXC	38	I	P1 MII reverse mode: external 25 MHz clock input
		O	P1 MII mode: 25 MHz receive clock output
P1_REF_CLK	38	I	P1 RMII mode: interface reference clock input (50 MHz external oscillator)
		O	P1 RMII mode: interface reference clock output (25 MHz crystal at PHY or 25 MHz clock at input of pin CLK_IN_OUT)
V _{DD(I/O)} ^[2]	39	P	3.3 V digital I/O supply voltage
P1_TXC	40	I	P1 MII reverse mode: external 25 MHz transmit clock input
		O	P1 MII mode: 25 MHz transmit clock output
P1_TXEN	41	I	P1 MII/RMII mode: transmit enable input (active-HIGH, weak pull-down)
P1_TXD3	42	I	P1 MII mode: transmit data input, bit 3 of TXD[3:0] nibble (weak pull-down)
P1_TXD2	43	I	P1 MII mode: transmit data input, bit 2 of TXD[3:0] nibble (weak pull-down)
P1_TXD1	44	I	P1 MII mode: transmit data input, bit 1 of TXD[3:0] nibble (weak pull-down) P1 RMII mode: transmit data input, bit 1 of TXD[1:0] nibble (weak pull-down)
P1_TXD0	45	I	P1 MII mode: transmit data input, bit 0 of TXD[3:0] nibble (weak pull-down) P1 RMII mode: transmit data input, bit 0 of TXD[1:0] nibble (weak pull-down)
P1_TXER	46	I	P1 MII/RMII: transmit error input (weak pull-down)
V _{DD(1V8)}	47	P	1.8 V digital supply voltage (configurable internal or external supply)
V _{DD(3V3)}	48	P	3.3 V digital supply voltage
GND ^[5]	49	G	ground reference

Table 2. TJA102A pin description...continued

Symbol	Pin	Type ^[1]	Description
XI	50	AI	crystal input - used in all MII/RMII and Reverse MII modes when a 25 MHz crystal is used
XO	51	AO	crystal feedback - used in all MII/RMII and reverse MII modes when a 25 MHz crystal is used
V _{DDA(3V3)}	52	P	3.3 V analog supply voltage
V _{DD(IO)} ^[2]	53	P	3.3 V digital I/O supply voltage
CLK_IN_OUT	54	IO	25 MHz reference clock input/output (configurable)
P0_RXER	55	O	P0 MII/RMII receive error output
CONFIG0	55	I	pin strapping configuration input 0
P1_TXCLK	55	O	P1 transmit clock output in test mode and during slave jitter test
P0_RXDV	56	O	P0 MII receive data valid output
P0_CRSDV	56	O	P0 RMII carrier sense/receive data valid output
CONFIG4	56	I	pin strapping configuration input 4

[1] AIO: analog input/output; AO: analog output; AI: analog input; I: digital input (V_{DD(IO)} related);

O: digital output (V_{DD(IO)} related); IO: digital input/output (V_{DD(IO)} related); P: power supply; G: ground.

[2] V_{DD(IO)} pins are connected internally and should be connected together on the PCB (pins 6, 31, 39 and 53).

[3] P0_V_{DDA(TX)} pins are connected internally and should be connected together on the PCB (pins 16 and 19).

[4] P1_V_{DDA(TX)} pins are connected internally and should be connected together on the PCB (pins 23 and 26).

[5] HVQFN56 package die supply ground is connected to both the GND pin and the exposed center pad. The GND pin must be soldered to board ground. For enhanced thermal and electrical performance, it is also recommended to connect the exposed center pad to board ground.

5.2 TJA1102AS pinning

The pin configuration of the TJA1102AS single PHY is shown in Figure 3.

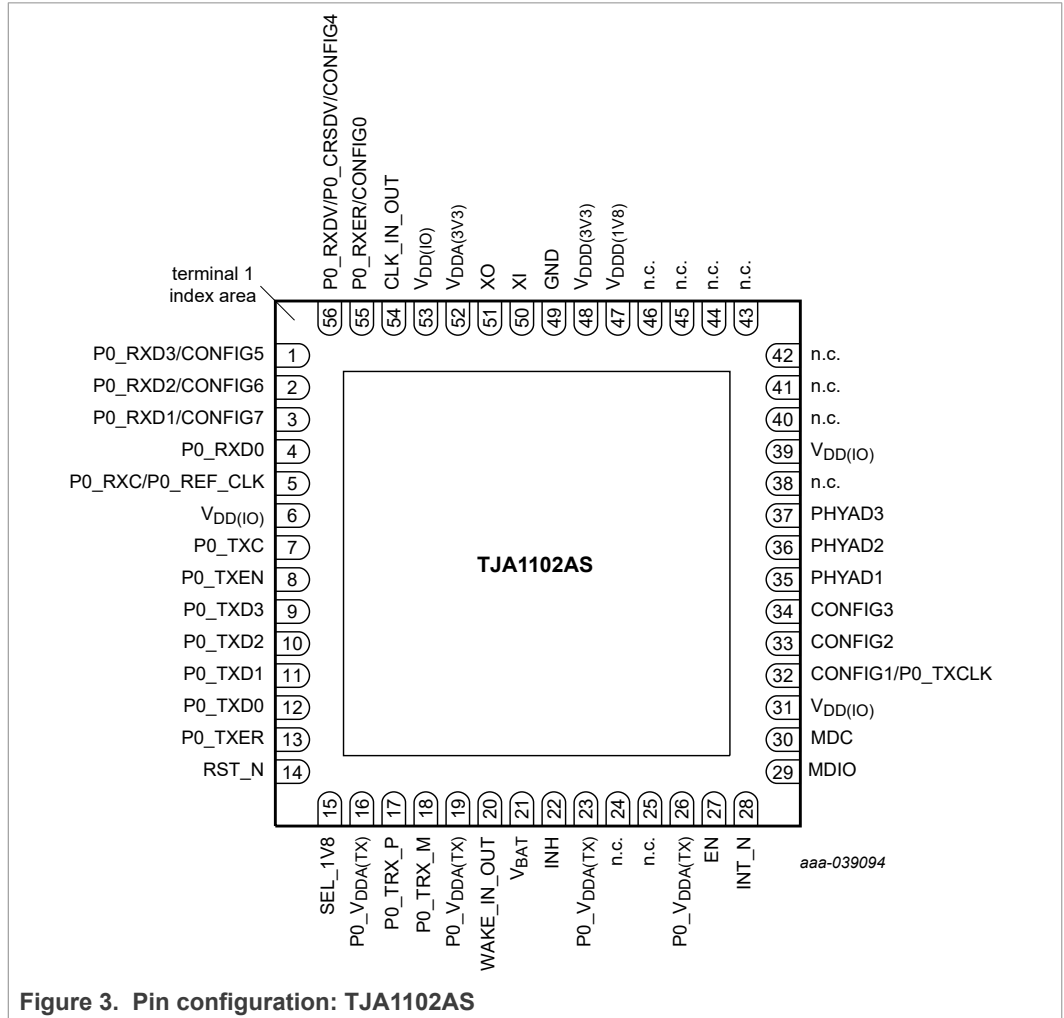

Table 3. TJA1102AS pin description

Symbol	Pin	Type ^[1]	Description
P0_RXD3	1	O	P0 MII mode: receive data output, bit 3 of RXD[3:0] nibble
CONFIG5	1	I	pin strapping configuration input 5
P0_RXD2	2	O	P0 MII mode: receive data output, bit 2 of RXD[3:0] nibble
CONFIG6	2	I	pin strapping configuration input 6
P0_RXD1	3	O	P0 MII mode: receive data output, bit 1 of RXD[3:0] nibble P0 RMII mode: receive data output, bit 1 of RXD[1:0] nibble
CONFIG7	3	I	pin strapping configuration input 7
P0_RXD0	4	O	P0 MII mode: receive data output, bit 0 of RXD[3:0] nibble P0 RMII mode: receive data output, bit 0 of RXD[1:0] nibble

Table 3. TJA1102AS pin description...continued

Symbol	Pin	Type ^[1]	Description
P0_RXC	5	I	P0 MII reverse mode: external 25 MHz clock input
		O	P0 MII mode: 25 MHz receive clock output
P0_REF_CLK	5	I	P0 RMII mode: interface reference clock input (50 MHz external oscillator)
		O	P0 RMII mode: interface reference clock output (25 MHz crystal at PHY or 25 MHz clock at input of pin CLK_IN_OUT)
V _{DD(I/O)} ^[2]	6	P	3.3 V digital I/O supply voltage
P0_TXC	7	I	P0 MII reverse mode: external 25 MHz transmit clock input
		O	P0 MII mode: 25 MHz transmit clock output
P0_TXEN	8	I	P0 MII/RMII mode: transmit enable input (active-HIGH, weak pull-down)
P0_TXD3	9	I	P0 MII mode: transmit data input, bit 3 of TXD[3:0] nibble (weak pull-down)
P0_TXD2	10	I	P0 MII mode: transmit data input, bit 2 of TXD[3:0] nibble (weak pull-down)
P0_TXD1	11	I	P0 MII mode: transmit data input, bit 1 of TXD[3:0] nibble (weak pull-down) P0 RMII mode: transmit data input, bit 1 of TXD[1:0] nibble (weak pull-down)
P0_TXD0	12	I	P0 MII mode: transmit data input, bit 0 of TXD[3:0] nibble (weak pull-down) P0 RMII mode: transmit data input, bit 0 of TXD[1:0] nibble (weak pull-down)
P0_TXER	13	I	P0 MII/RMII: transmit error input (weak pull-down)
RST_N	14	I	reset input (active-LOW; weak pull-up)
SEL_1V8	15	I	1.8 V LDO mode selection (external or internal; weak pull-down)
P0_V _{DDA(TX)} ^[3]	16	P	3.3 V analog supply voltage for the P0 transmitter
P0_TRX_P	17	AIO	+ terminal for P0 transmit/receive signal
P0_TRX_M	18	AIO	- terminal for P0 transmit/receive signal
P0_V _{DDA(TX)} ^[3]	19	P	3.3 V analog supply voltage for the P0 transmitter
WAKE_IN_OUT	20	AIO	local/forwarding wake-up input/output (configurable)
V _{BAT}	21	P	battery supply voltage
INH	22	AO	inhibit output for voltage regulator control (V _{BAT} -related, active-HIGH)
P0_V _{DDA(TX)} ^[3]	23	P	3.3 V analog supply voltage for the P0 transmitter
n.c.	24	-	not connected; pin can be left open or shorted to GND
n.c.	25	-	not connected; pin can be left open or shorted to GND
P0_V _{DDA(TX)} ^[3]	26	P	3.3 V analog supply voltage for the P0
EN	27	I	PHY enable input (active-HIGH, weak pull-down)
INT_N	28	O	interrupt output (active-LOW, open-drain output, level-based)
MDIO	29	IO	SMI data I/O (weak pull-up)
MDC	30	I	SMI clock input (weak pull-down)
V _{DD(I/O)} ^[2]	31	P	3.3 V digital I/O supply voltage
CONFIG1	32	I	pin strapping configuration input 1
P0_TXCLK	32	O	P0 transmit clock output in test mode and during slave jitter test
CONFIG2	33	I	pin strapping configuration input 2

Table 3. TJA1102AS pin description...continued

Symbol	Pin	Type ^[1]	Description
CONFIG3	34	I	pin strapping configuration input 3
PHYAD1	35	I	pin strapping configuration input for bit 1 of the PHY address used for the SMI address/Cipher scrambler
PHYAD2	36	I	pin strapping configuration input for bit 2 of the PHY address used for the SMI address/Cipher scrambler
PHYAD3	37	I	pin strapping configuration input for bit 3 of the PHY address used for the SMI address/Cipher scrambler
n.c.	38	-	not connected; pin can be left open or shorted to GND
V _{DD(I/O)} ^[2]	39	P	3.3 V digital I/O supply voltage
n.c.	40	-	not connected; pin can be left open or shorted to GND
n.c.	41	-	not connected; pin can be left open or shorted to GND
n.c.	42	-	not connected; pin can be left open or shorted to GND
n.c.	43	-	not connected; pin can be left open or shorted to GND
n.c.	44	-	not connected; pin can be left open or shorted to GND
n.c.	45	-	not connected; pin can be left open or shorted to GND
n.c.	46	-	not connected; pin can be left open or shorted to GND
V _{DDD(1V8)}	47	P	1.8 V digital supply voltage (configurable internal or external supply)
V _{DDD(3V3)}	48	P	3.3 V digital supply voltage
GND ^[4]	49	G	ground reference
XI	50	AI	crystal input - used in all MII/RMII and Reverse MII modes when a 25 MHz crystal is used
XO	51	AO	crystal feedback - used in all MII/RMII and reverse MII modes when a 25 MHz crystal is used
V _{DDA(3V3)}	52	P	3.3 V analog supply voltage
V _{DD(I/O)} ^[2]	53	P	3.3 V digital I/O supply voltage
CLK_IN_OUT	54	IO	25 MHz reference clock input/output (configurable)
P0_RXER	55	O	P0 MII/RMII receive error output
CONFIG0	55	I	pin strapping configuration input 0
P0_RXDV	56	O	P0 MII receive data valid output
P0_CRSDV	56	O	P0 RMII carrier sense/receive data valid output
CONFIG4	56	I	pin strapping configuration input 4

[1] AIO: analog input/output; AO: analog output; AI: analog input; I: digital input (V_{DD(I/O)} related);

O: digital output (V_{DD(I/O)} related); IO: digital input/output (V_{DD(I/O)} related); P: power supply; G: ground.

[2] V_{DD(I/O)} pins are connected internally and should be connected together on the PCB (pins 6, 31, 39 and 53).

[3] P0_V_{DDA(TX)} pins are connected internally and should be connected together on the PCB (pins 16, 19, 23 and 26).

[4] HVQFN56 package die supply ground is connected to both the GND pin and the exposed center pad. The GND pin must be soldered to board ground. For enhanced thermal and electrical performance, it is also recommended to connect the exposed center pad to board ground.

6 Functional description

6.1 System configuration

The TJA1102A comprises two 100BASE-T1 compliant Ethernet PHYs, with 100 Mbit/s transmit and receive capability over two unshielded twisted-pair cables. The TJA1102A supports a cable length of up to at least 15 m, with a bit error rate of 1E-10 or less. It is optimized for capacitive signal coupling to the twisted-pair lines. A common-mode choke is typically inserted into the signal path to comply with automotive EMC requirements.

The TJA1102A is designed to provide a cost-optimized system solution for automotive Ethernet links. It communicates with the Media Access Control (MAC) unit via the MII or RMII interface. In combination with other devices (e.g. SJA1105 in [Figure 4](#)), it offers a highly flexible 4-port switch solution, with two TJA1102A dual PHYs providing the 100BASE-T1 physical layer ports.

The TJA1102A can operate with a crystal or an external clock. The clock can be forwarded to other PHYs (in the application diagram in [Figure 4](#), the clock of one TJA1102A is used as reference for a second TJA1102A). The clocking and power supply schemes are independent of each other.

The TJA1102A can be powered via a single 3.3 V supply. An internal LDO generates the required 1.8 V supply, requiring only the addition of a decoupling capacitor.

When the TJA1102A is used in a switch application with several PHY ports, it may be more efficient to use an external SMPS to provide the 1.8 V supply. In this configuration, the internal LDO is switched off to allow an external supply to be used.

The state of SEL_1V8 is captured and copied to bit LDO_MODE (see [Table 12](#)) when the device is powered up. A bit value of 0 enables the internal 1.8 V LDO. If LDO_MODE = 1, the internal LDO is disabled and $V_{DD(1V8)}$ must be supplied externally. The value of LDO_MODE can be changed after power-up via register access.

Control and status information is exchanged with the host controller via the SMI interface. The INH output can be used to switch off the external regulator when all ports are in Sleep mode.

Note that the dual-port PHY can be configured to operate as a single PHY via pin strapping or the SMI. Alternatively, a TJA1102AS could be used when only a single PHY is needed.

A PCB layout based on the system diagrams shown in [Section 6.1.1](#) and [Section 6.1.2](#) would be able to accommodate any switch configuration comprising between one and four ports.

6.1.1 Clocking scheme with MII and clock provided by the switch and one of the TJA1102A devices

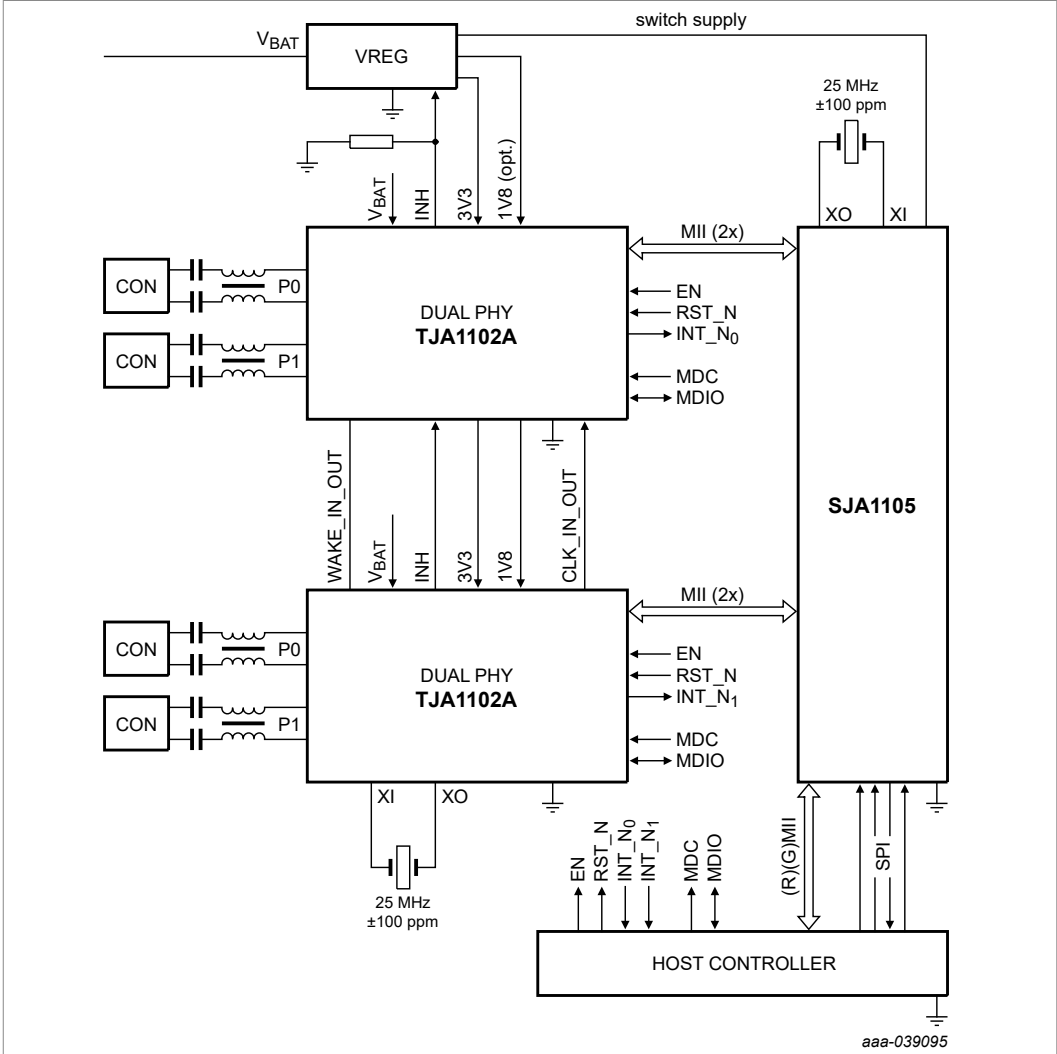

One of the TJA1102A devices could be replaced by a TJA1102AS if only three PHYs are needed.

Figure 4. Typical TJA1102A MII switch application with SJA1105

6.1.2 Clocking scheme with RMIi and clock provided by the switch

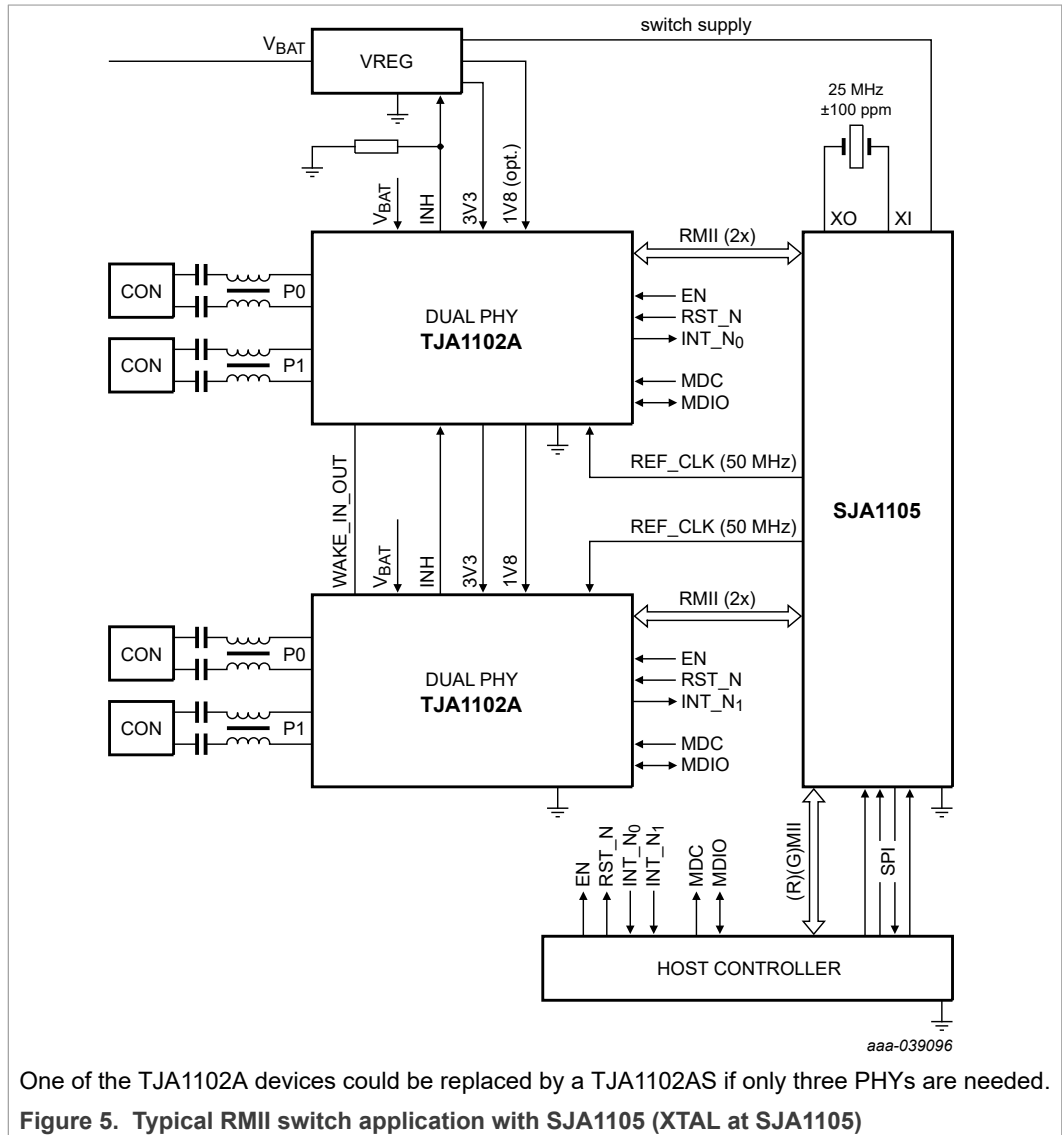

6.2 MII and RMIi

The TJA1102A supports a number of MII modes that can be selected via pin strapping or the SMI. The PHYs should be configured to operate in the same mode, with common clocking. The following modes are supported:

- MII
- RMIi (25 MHz XTAL or external 50 MHz via REF_CLK)
- Reverse MII (connected externally or internally to the second PHY)

Refer to the SMI register description ([Section 6.11](#)) for further configuration options. The strength of the (R)MIi output driver signals can be limited in all modes (via bit MII_DRIVER; [Table 22](#)) to optimize EMC behavior.

6.2.1 MII

The connections between the PHY and the MAC are shown in more detail in [Figure 6](#). Data is exchanged via 4-bit wide data nibbles on TXD[3:0] and RXD[3:0]. Transmit and receive data is synchronized with the transmit (TXC) and receive (RXC) clocks. Both clock signals are provided by the PHY and are typically derived from an external clock or crystal running at a nominal frequency of 25 MHz (±100 ppm). Normal data transmission is initiated with a HIGH level on TXEN, while a HIGH level on RXDV indicates normal data reception.

MI1 encoding is described in [Table 4](#) and [Table 5](#).

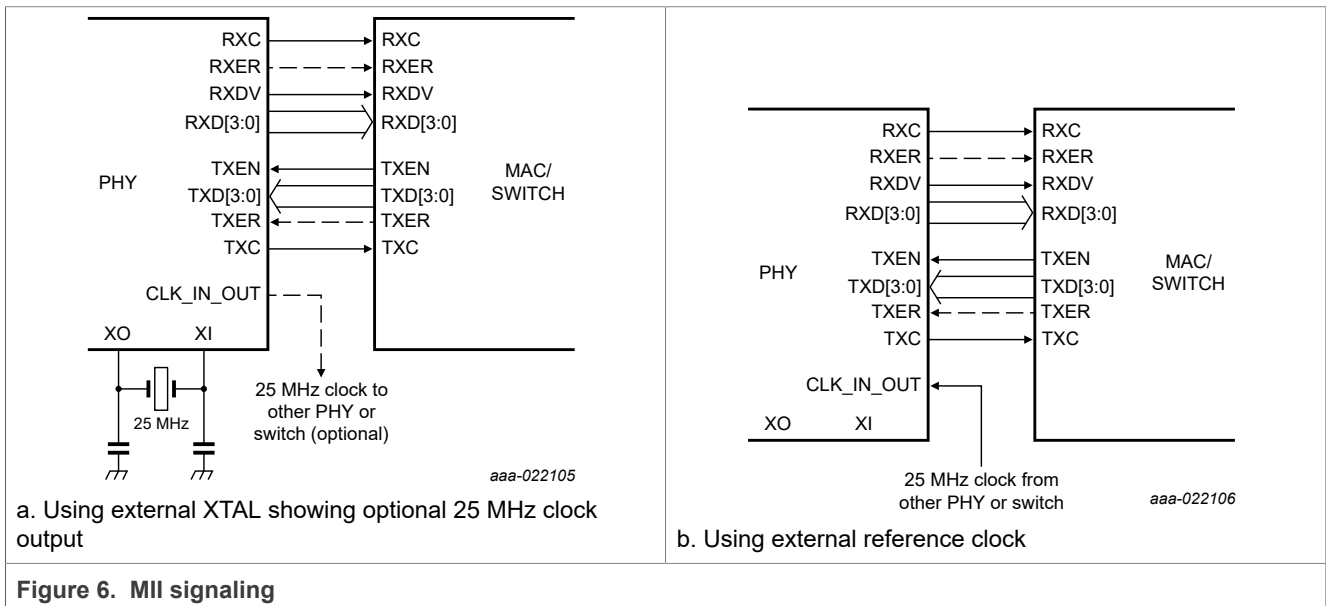

Table 4. MII encoding of TXD[3:0], TXEN and TXER

TXEN	TXER	TXD[3:0]	Indication
0	0	0000 through 1111	normal interframe
0	1	0000 through 1111	reserved
1	0	0000 through 1111	normal data transmission
1	1	0000 through 1111	transmit error propagation

Table 5. MII encoding of RXD[3:0], RXDV and RXER

RXDV	RXER	RXD[3:0]	Indication
0	0	0000 through 1111	normal interframe
0	1	0000	normal interframe
0	1	0001 through 1101	reserved
0	1	1110	false carrier indication
0	1	1111	reserved
1	0	0000 through 1111	normal data transmission

Table 5. MII encoding of RXD[3:0], RXDV and RXER...continued

RXDV	RXER	RXD[3:0]	Indication
1	1	0000 through 1111	data reception with errors

6.2.2 RMII

6.2.2.1 Signaling and encoding

RMII data is exchanged via 2-bit wide data nibbles on TXD[1:0] and RXD[1:0], as illustrated in [Figure 7](#). To achieve the same data rate as MII, the interface is clocked at a nominal frequency of 50 MHz. A single clock signal, REF_CLK, is provided for both transmitted and received data. This clock signal is provided by the PHY and is typically derived from an external 25 MHz (± 100 ppm) crystal (see [Figure 7](#) (a)). Alternatively, a 50 MHz clock signal (± 50 ppm) generated by an external oscillator can be connected to pin REF_CLK (see [Figure 7](#) (b)). A third option is to connect a 25 MHz (± 100 ppm) clock signal generated by another PHY or switch to pin CLK_IN_OUT (see [Figure 7](#) (c)).

RMII encoding is described in [Table 6](#) and [Table 7](#).

Table 6. RMII encoding of TXD[1:0], TXEN

TXEN	TXD[1:0]	Indication
0	00 through 11	normal interframe
1	00 through 11	normal data transmission

Table 7. RMII encoding of RXD[1:0], CRSDV and RXER

CRSDV	RXER	RXD[1:0]	Indication
0	0	00 through 11	normal interframe
0	1	00	normal interframe
0	1	01 through 11	reserved
1	0	00 through 11	normal data transmission
1	1	00 through 11	data reception with errors

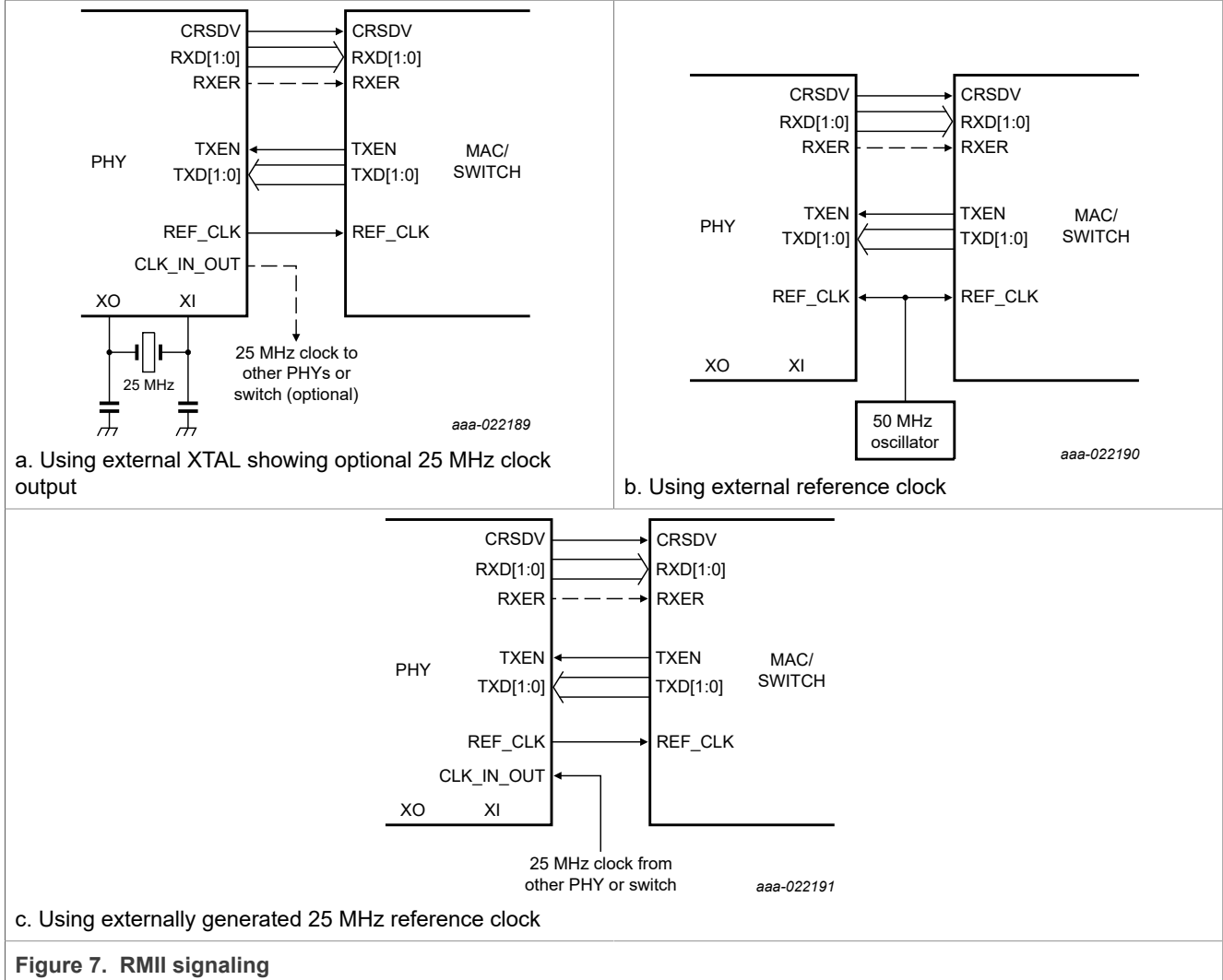

Figure 7. RMII signaling

6.2.3 Reverse MII

In Reverse MII mode, two PHYs are connected back-to-back via the MII interface to realize a repeater function on the physical layer. The MII signals are cross-connected: RX output signals from one PHY are connected to the TX inputs on the other PHY. The TXC and RxC clock signals become inputs on the PHY connected in Reverse MII mode (P0 in Figure 8 and Figure 9). Reverse MII mode is selected by setting bits MII_MODE = 11.

Two configuration options are available on the TJA1102A. The P0 and P1 MII pins can be connected externally on the PCB (INT_REV_MII = 0). Alternatively, the MII ports can communicate via existing internal connections (INT_REV_MII = 1), as illustrated in Figure 8.

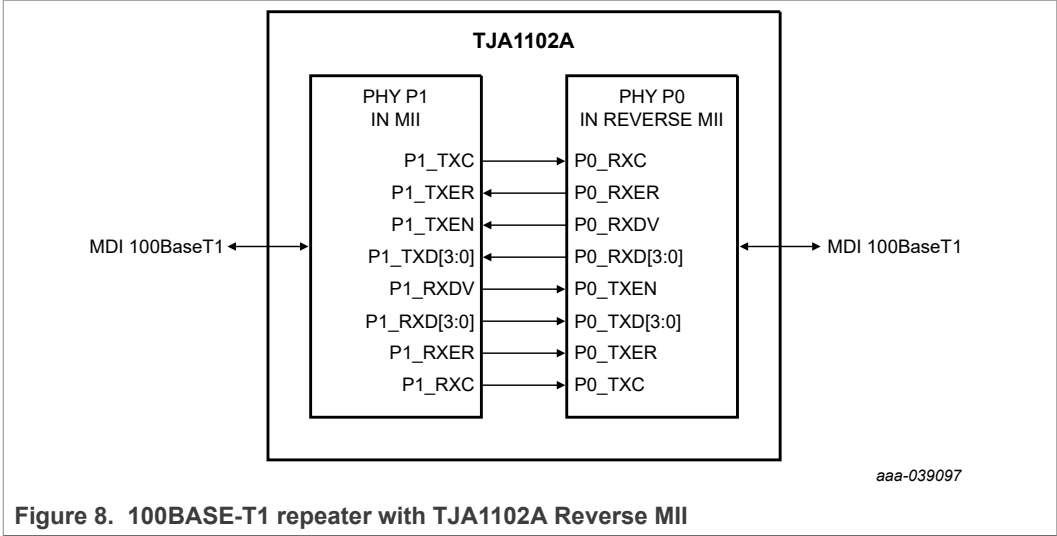

Figure 8. 100BASE-T1 repeater with TJA1102A Reverse MII

The TJA1102AS can be configured in reverse MII mode by connecting the MII pins externally to a fast Ethernet product, is illustrated in [Figure 9](#).

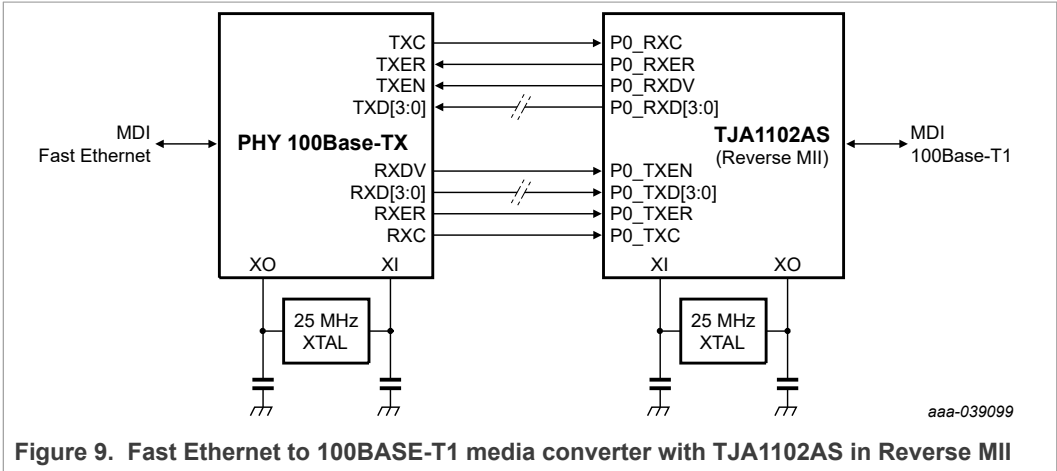

Figure 9. Fast Ethernet to 100BASE-T1 media converter with TJA1102AS in Reverse MII

6.3 System controller

6.3.1 Operating modes

6.3.1.1 Power-off mode

Each PHY has its own dedicated power mode state machine. The TJA1102A remains in Power-off mode as long as the voltage on pin V_{BAT} is below the power-on reset threshold. The analog blocks are disabled and the digital blocks are in a passive reset state in this mode.

6.3.1.2 Standby mode

At power-on, when the voltage on pin V_{BAT} rises above the under-voltage recovery threshold (V_{uvr(VBAT)}), the TJA1102A enters Standby mode and switches on the INH control output (pin INH HIGH). This control signal may be used to activate the supply to

the microcontroller in the ECU. Once the 3.3 V supply voltage is available, the internal 1.8 V regulator is activated (if selected) and the PHYs are configured according to the pin strapping implemented on the CONFIGn and PHYADn pins. No SMI access takes place during the power-on settling time ($t_{s(pon)}$).

From an operating point of view, Standby mode corresponds to the IEEE 802.3 Power-down mode, where the transmit and receive functions (in the PHY) are disabled. Standby mode also acts as a fail-silent mode. The TJA1102A switches to Standby mode when an undervoltage condition is detected on $V_{DDA(3V3)}$, $V_{DDD(3V3)}$, $V_{DDD(1V8)}$ or $V_{DD(10)}$.

6.3.1.3 Normal mode

To establish a communication link, the TJA1102A must be switched to Normal mode, either autonomously (AUTO_OP = 1; see [Table 31](#)) or via an SMI command from the host (AUTO_OP = 0).

When the TJA1102A is configured for autonomous operation, the PHYs enter Normal mode automatically and activate the link on power-on. When the TJA1102A is host-controlled, the PHYs must be enabled via the SMI.

When a PHY is enabled and enters Normal mode, the internal PLL starts running and the transmit and receive functions (both PCS and PMA) are enabled. After a period of stabilization, $t_{init(PHY)}$, the PHY is ready to set up a link.

If link control is enabled (LINK_CONTROL = 1; see [Table 21](#)), a PHY configured as Master initiates the training sequence by transmitting an idle pattern. The receiver of a PHY configured as Slave will attempt to synchronize with the idle pattern. Once the descrambler is synchronized (SCR_LOCKED = 1), the slave PHY itself starts sending an idle pattern using the recovered clock signal.

The link is established (LINK_STATUS = 1) when the TJA1102A PHY and the remote PHY indicate that their local receiver status is OK.

6.3.1.4 Disable mode

When the Ethernet interface is not in use or must be disabled for fail-safe reasons, the PHYs can be switched off by pulling pin EN LOW. The PHYs are switched off completely in Disable mode, minimizing power consumption. The configuration register settings are maintained. EN must be forced HIGH to exit Disable mode and activate the PHYs. The PHYs can also be enabled/disabled via bit PHY_EN.

6.3.1.5 Sleep mode

If the network manager decides to withdraw a node from the network because it is no longer needed, the PHYs can be switched to Sleep mode (powering down the entire ECU).

In Sleep mode, the transmit and receive functions are switched off and no signal is driven onto the twisted-pair lines. Transmit requests from the MII interface are ignored and the MII output pins are in a high-ohmic state. The only valid SMI operations in Sleep mode are reading the POWER_MODE status bits in the Extended control register and issuing a Standby mode command (POWER_MODE = 1100; see [Table 21](#)).

Releasing the INH output (INH LOW) allows the ECU to switch off its main power supply unit. Typically, the entire ECU is powered-down. The TJA1102A is kept partly alive by the permanent battery supply and can still react to activity on the Ethernet lines. Once valid Ethernet idle pulses longer than $t_{det(PHY)}$ are detected on the lines of at least one PHY (with REMWUPHY = 1), the TJA1102A wakes up in Standby mode and switches on

the main power unit via the INH control signal. The TJA1102A PHYs enter Normal mode via autonomous operation once the supply voltages are stable within their operating ranges, or can be switched to Normal mode via an SMI command if host-controlled. The communication link to the partner can then be re-established. Only PHY0 switches to Normal mode in the TJA1102AS.

Sleep mode can be entered from Normal mode via the intermediate Sleep Request mode as well as from Standby mode, as shown in [Figure 10](#). Note that the configuration register settings are maintained in Sleep mode.

If CLK_IN_OUT is used to provide the clock for other devices (e.g. other PHYs), the clock signal can be configured to remain active (CLK_HOLD = 1) along with INH even when both PHYs are in Sleep mode or disabled. When CLK_HOLD = 1, the device enters Sleep mode automatically but remains active until a FORCE_SLEEP SMI command is received. Note that this command forces both PHYs to Sleep mode immediately (if they are not already in Sleep mode or disabled).

6.3.1.6 Sleep Request mode

Sleep Request mode is an intermediate state used to initiate a transition to Sleep mode. In Sleep Request mode, the PHY transmits scrambler code with an encoded LPS command to inform the link partner about the request to enter Sleep mode.

The PHY sleep request timer ($t_{to(req)sleep}$; see [Table 38](#)) starts when the TJA1102A enters Sleep Request mode. This timer determines the maximum length of time the PHY remains in Sleep Request mode. The PHY switches to Sleep mode (via an intermediate step through Silent mode) on receiving LPS confirmation of the sleep request from the Link partner. If the timer expires before confirmation is received from the link partner, the PHY returns to Normal mode. This process is valid when LPS_ACTIVE = 1 and SLEEP_CONFIRM = 1.

If bit SLEEP_ACK is not set when the PHY enters Sleep Request mode, it switches back to Normal mode if data is detected on MII or MDI (see [Table 22](#)). The DATA_DET_WU flag in the General status register is set and a WAKEUP interrupt is generated (if REMWUPHY = 1).

If SLEEP_ACK is set when the PHY enters Sleep Request mode, the PHY sleep acknowledge timer ($t_{to(ack)sleep}$; see [Table 38](#)) is started. While the timer is running, the PHY switches back to Normal mode in response to a host command or wake-up request. When the timer expires, LPS transmission begins to initiate a transition to Sleep mode. Data detected at MII or MDI is ignored.

INH is released when both PHYs are in Sleep mode or disabled.

6.3.1.7 Silent mode

Silent mode is an intermediate state between Sleep Request mode and Sleep mode. It is provided to allow time to switch off the transmitter after a sleep request has been accepted before entering Sleep mode. The TJA1102A switches to Sleep mode once the channel goes silent.

If the channel remains active for longer than $t_{to(req)sleep}$, the PHY returns to Normal mode and a SLEEP_ABORT interrupt is generated.

6.3.1.8 Reset mode

The TJA1102A switches to Reset mode from any mode except Power-off or Sleep when pin RST_N is held LOW for at least $t_{det(rst)(max)}$, provided the voltage on $V_{DD(I/O)}$ is above the undervoltage threshold.

When RST_N goes HIGH again, or an undervoltage is detected on $V_{DD(I/O)}$, the TJA1102A switches to Standby mode. All register bits are reset to their default values in Reset mode and the state of the pin strapping pins is captured.

6.3.2 Status of functional blocks in TJA1102A operating modes

Table 8 presents an overview of the status of TJA1102A functional blocks in each operating mode.

Table 8. Status of functional blocks in TJA1102A operating modes

Functional block	Normal	Standby	Sleep Request	Sleep ^[1]	Disable
MII	on	high-ohmic ^[2]	on	high-ohmic	high-ohmic
PMA/PCS-TX	on	off	on	off	off
PMA/PCS-RX	on	off	on	off	off
SMI	on	on	on	on ^[3]	off
Activity detection	off	on	off	on	off
Crystal oscillator	on/off ^[4]	off	on/off ^[4]	off ^[5]	off
LDO_1V8	on/off ^[6]	on/off ^[6]	on/off ^[6]	off	off
RST_N input	on	on	on	off	on
EN input	on	on	on	off	on
WAKE_IN_OUT	on/off ^[7]	on/off ^[7]	on/off ^[7]	on/off ^[7]	off
INT_N output	on	on	on	high-ohmic	high-ohmic
INH output	on	on	on	off	on/off ^[8]
Temp detection	on	on	on	off	off

[1] The TJA1102A only switches to Sleep mode if both PHYs are in Sleep mode or disabled via SMI-access ($PHY_EN = 0$). The TJA1102AS will be in Sleep mode if PHY0 is in Sleep mode (since PHY1 is disabled).

[2] Outputs RXD[3:0], RXER and RXDV are LOW in Standby mode; the other MII pins are configured as inputs via internal 100 kΩ pull-down resistors.

[3] Limited access to SMI registers in Sleep mode to allow mode control/wake-up via SMI. $V_{DD(I/O)}$ must be available.

[4] Configurable; depends on bits CLK_MODE in the Common configuration register.

[5] The crystal will be off in Sleep mode unless bit CLK_HOLD = 1 and bits CLK_MODE = 00 or 01.

[6] Configurable; $V_{DD(1V8)}$ can be supplied internally (bit LDO_MODE in the Common configuration register LOW) or externally (bit LDO_MODE HIGH).

[7] Configurable.

[8] The behavior of the INH output in Disable mode is configurable and depends on bit CONFIG_INH in the Common configuration register.

6.4 Mode transitions

A mode transition diagram for the TJA1102A is shown in [Figure 10](#). Abbreviations used in the mode transition diagram are defined in [Table 9](#).

The following events, listed in order of priority, trigger mode transitions:

- Power on/off
- Undervoltage on $V_{DD(I/O)}$
- RST_N input
- EN input
- Overtemperature or Undervoltage on $V_{DDA(3V3)}$, $V_{DDD(3V3)}$, $V_{DDD(1V8)}$
- SMI command and wake-up (local, remote or forwarding)

Table 9. State diagram legend

Transition	Abbreviation	Description
Silent to Normal	sleep request timer expired	$t > t_{to(req)sleep}$
Normal to Sleep Request	Sleep Request command	POWER_MODE = 1011
	autonomous power-down	no frame transmission or reception for longer than $t_{to(pd)autn}$ AND AUTO_PWD = 1
	LPS code group received	LPS_WUR_DIS = 0 (LPS/WUR enabled) AND LPS_RECEIVED = 1 AND $t > t_{to(req)sleep}$ AND LPS_ACTIVE = 1
	no data detected on MDI or MII	pcs_rx_dv = FALSE AND TXEN = LOW
	sleep acknowledge timer enabled	SLEEP_ACK = 1
Sleep Request to Normal	Normal mode command	POWER_MODE = 0011
	wake-up request	(FWDPHYREM = 1 and WAKEUP = 1) OR WUR symbols received at the bus pins
	sleep acknowledge timer disabled	SLEEP_ACK = 0
	sleep acknowledge time-out time not expired	$t < t_{to(ack)sleep}$
	data detected on MDI or MII	pcs_rx_dv = TRUE OR TXEN = HIGH
	LPS enabled	LPS_WUR_DIS = 0
	sleep request timer expired	$t > t_{to(req)sleep}$
Normal to Normal	data detected on MDI or MII	pcs_rx_dv = TRUE OR TXEN = HIGH
	sleep acknowledge timer disabled	SLEEP_ACK = 0
Sleep Request to Sleep	LPS disabled	LPS_WUR_DIS = 1
	sleep request timer expired	$t > t_{to(req)sleep}$
Sleep Request to Silent	LPS enabled	LPS_WUR_DIS = 0
Standby to Normal	autonomous operation	see Section 6.6

6.5 Sleep and wake-up forwarding concept

The sleep and wake-up forwarding concept of the TJA1102A is compliant with the OPEN Alliance Sleep/Wake-up specification. The TJA1102A features a wake-up request forwarding function that enables fast wake-up forwarding without the need for a switch, MAC or μC action. The wake-up forwarding principle is illustrated in Figure 11. The wake-up request can be forwarded via non-active (gray PHYs in the figure) or active links (white PHY). In the case of a non-active link, a wake-up pulse (WUP; duration $t_{w(\text{wake})}$) is transmitted, to be detected as activity at the link partner. For an active link, wake up request (WUR) scrambler code groups are sent.

The wake-up behavior of the PHYs can be configured individually. This arrangement allows WAKE_IN_OUT to be used as a local wake-up or to have a mixed system with only some ports forwarding wake-up requests. The following configuration options are available and are selected via the SMI Configuration register 1 (Table 22):

REMWUPHY determines whether a PHY reacts to a remote wake-up request.

FWDPHYREM determines whether a PHY forwards a wake-up request (from another port or via WAKE_IN_OUT) to its MDI. A WUP or WUR is sent, depending on the link status.

LOCWUPHY determines whether a PHY should be woken up in response to a local wake-up event (forwarded from another port or via WAKE_IN_OUT)

FWDPHYLOC determines whether wake-up event should be forwarded to other ports (i.e. should the second PHY be informed and/or the WAKE_IN_OUT signal activated).

The WAKE_IN_OUT signal features a programmable timeout to enable it to support a number of wake-up concepts (e.g. wake-up line). It reacts on a rising edge.

The wake-up detection time, $t_{\text{det}(\text{wake})}$ (see Table 38), on pin WAKE_IN_OUT is determined by register bit settings LOC_WU_TIM (see Table 29). The wake-up pulse duration (t_p ; see Table 38) is also determined by LOC_WU_TIM.

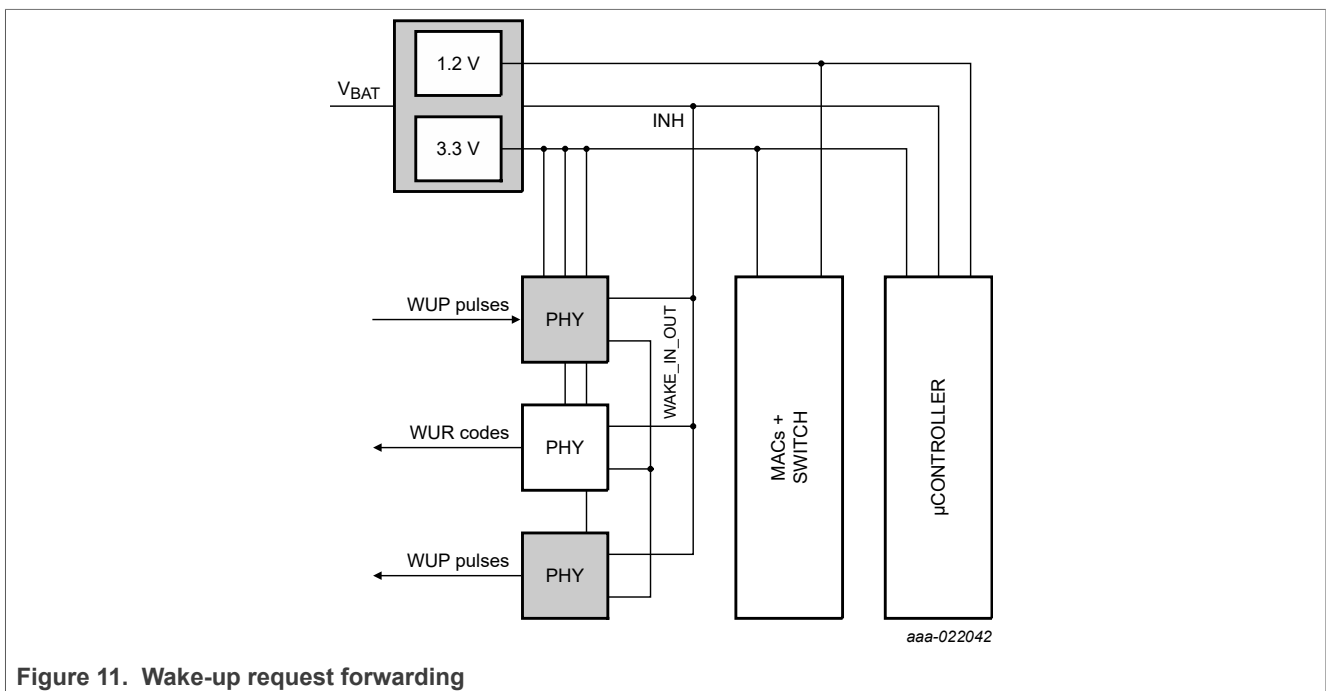

Figure 11. Wake-up request forwarding

6.6 Autonomous operation

When the TJA1102A is configured for autonomous operation (either via pin strapping, see [Section 6.10](#), or via bit AUTO_OP in the Common configuration register, [Table 29](#)), it can operate and establish a link without further interaction with a host controller. On power-on or wake-up from Sleep mode, the TJA1102A goes directly to Normal mode once all supply voltages are available and the link-up process starts automatically. Host configuration (e.g. for link or mode control) will not be possible until the device is switched from autonomous to managed operation by resetting bit AUTO_OP.

6.7 Autonomous power-down

If autonomous power-down is enabled for a PHY (AUTO_PWD = 1), it goes to Sleep Request mode automatically if no Ethernet frames have been received at the MDI and (R)MII within the timeout time, $t_{to(pd)autn}$.

6.8 Test modes

Five test modes are supported. Only test modes 1, 2, 4 and 5 are included in the 100BASE-T1 specification [\[1\]](#). The test modes can be selected individually via an SMI command in Normal mode while link control is disabled. Pin P1_RXER is used as a reference clock output for PHY0 test modes 1 to 4; pin P0_RXER is used as a reference clock output for PHY1 test modes 1 to 4 (the nominal P1_RXER/P0_RXER function is disabled when test modes are active). No load should be connected when the reference clock is being measured.

6.8.1 Test mode 1

Test mode 1 is used to test transmitter droop. In Test mode 1, the PHY transmits '+1' symbols for 600 ns followed by '-1' symbols for a further 600 ns. This sequence is repeated continuously.

6.8.2 Test mode 2

Test mode 2 is used to test transmitter timing jitter in Master mode. In Test mode 2, the PHY transmits the data symbol sequence {+1, -1} repeatedly. The transmission of the symbols is synchronized with the local external oscillator.

6.8.3 Test mode 3

Test mode 3 is used to test transmitter timing jitter in Slave mode. In Test mode 3, the PHY transmits the data symbol sequence {+1, -1} repeatedly. The transmission of the symbols is synchronized with the local external oscillator.

6.8.4 Test mode 4

Test mode 4 is used to test transmitter distortion. In Test mode 4, the PHY transmits the sequence of symbols generated by the scrambler polynomial $gs1 = 1 + x9 + x11$.

The bit sequence $x0n$, $x1n$ is derived from the scrambler according to the following equations:

$$x0n = Scrn[0]$$

$$x1n = Scrn[1] \text{ XOR } Scrn[4]$$

This stream of 3-bit nibbles is mapped to a stream of ternary symbols according to [Table 10](#).

Table 10. Symbol mapping in test mode 4

x1n	x0n	PAM-3 transmit symbol
0	0	0
0	1	+1
1	0	0
1	1	-1

6.8.5 Test mode 5

Test mode 5 is used to test the transmit PSD mask. In Test mode 5, the PHY transmits a random sequence of PAM-3 symbols.

6.8.6 Slave jitter test

To enable the Slave jitter test in Normal mode, bit SLAVE_JITTER_TEST must be set to 1 before link control is enabled (LINK_CONTROL = 1; see [Table 21](#)). During this test, the transmitter reference clock is fed to pin P1_TXCLK for PHY1 and/or P0_TXCLK for PHY0 of the TJA1102A. For the TJA1102AS, the transmitter reference clock is fed to pin P0_TXCLK.

6.9 Error diagnosis

The diagnostic features described in this section are available individually for each dual-PHY port, except for undervoltage detection of common supply voltages.

6.9.1 Undervoltage detection

The TJA1102A continuously monitors the status of the supply voltages. Once a supply voltage drops below the specified minimum operating threshold, the TJA1102A enters the fail-silent Standby mode and communication is halted. If an undervoltage is detected on V_{BAT}, the TJA1102A switches to Power-off mode.

At power-on, after a transition from Power-off to Standby mode, undervoltage detection timeout is enabled once all supply voltages are available. The timeout timer is started when an undervoltage is detected. If the undervoltage is still active when the timer expires (after t_{to(uvd)}), the TJA1102A switches from Standby mode to Sleep mode.

The microcontroller can determine the source of the interruption by reading the contents of the External status register ([Table 29](#)). The under-voltage detection/recovery range is positioned immediately next to the operating range, without a gap. Since parameters are specified down to the minimum value of the under-voltage detection threshold, it is guaranteed that the behavior of the TJA1102A is fully specified and defined for all possible voltage condition on the supply pins.

6.9.2 Cabling errors

The TJA1102A can detect open and short circuits between the twisted-pair bus lines when neither of the link partners is transmitting (link control disabled). It may make sense to run the diagnostic before establishing the Ethernet link. When bit CABLE_TEST in the Extended Control register (Table 21) is set to 1, test pulses are transmitted onto the transmission medium with a repetition rate of 666.6 kHz. The TJA1102A evaluates the reflected signals and uses impedance mismatch data along the channel to determine the quality of the link. The results of the cable test are available in the External status register (Table 29) within $t_{to(cbl_tst)}$. The tests performed and associated results are summarized in Table 11.

Table 11. Cable tests and results

The cable bus lines are designated BI_DA+ and BI_DA-, in alignment with 100BASE-T1 [1].

BI_DA+	BI_DA-	Result
open	open	open detected
+ shorted to -	- shorted to +	short detected
shorted to V _{DD}	open	open detected
open	shorted to V _{DD}	open detected
shorted to V _{DD}	shorted to V _{DD}	short detected
shorted to GND	open	open detected
open	shorted to GND	open detected
shorted to GND	shorted to GND	short detected
connected to active link partner (master)	connected to active link partner (master)	short and open detected

6.9.3 Link stability

The Signal Quality Indicator (SQI) is the parameter used to estimate link stability. The PMA receive function monitors the SQI. Once the value falls below a configurable threshold (SQI_FAILLIMIT), the link status is set to FAIL and communication is interrupted. The TJA1102A allows for adjusting the sensitivity of the PMA receive function by configuring this threshold. The microcontroller can always check the current value of the SQI via the SMI, allowing it to track a possible degradation in link stability.

6.9.4 Link-fail counter

High losses and/or a noisy channel may cause the link to shut down when reception is no longer reliable. In such cases, the PHY generates a LINK_STATUS_FAIL interrupt. Retraining of the link begins automatically provided link control is enabled (LINK_CONTROL = 1).

Bits LOC_RCVR_COUNTER and REM_RCVR_COUNTER in the Link-fail counter register (Table 30) are incremented after every link fail event. Both counters are reset when this register is read.

6.9.5 Jabber detection

The Jabber detection function prevents the PHY being locked in the DATA state of the PCS Receive state diagram when the End-of-Stream Delimiters, ESD1 and ESD2, are not detected.

The maximum time the PHY can reside in the DATA state is limited to $t_{lo(PCS-RX)}$ (rcv_max_timer in the IEEE specification [1]). After this time, the PCS-RX state machine is reset, triggering a transition to PHY Idle state.

6.9.6 Polarity detection

A polarity error occurs when the two signal wires in the twisted pair cable connected to a port are swapped. According to the IEEE specification [1], the polarity is always observed to be correct by the Master PHY; only the Slave is allowed to correct the polarity. When the TJA1102A is in Slave configuration, it can detect if the ternary symbols sent from the Master PHY are received with the wrong polarity and will correct this error internally and set the POLARITY_DETECT bit in the External status register (Table 29). Irrespective of the Master or Slave mode, the host can overwrite and swap the default MDI polarity by setting MDI_POL in Configuration Register 3 (Table 32).

6.9.7 Interleave detection

A 100BASE-T1 PHY can send two different interleave sequences of ternary symbols (TAn, TBn) or (TBn, TAn). The receivers in the TJA1102A are able to de-interleave both sequences. The order of the ternary symbols detected by the receiver is indicated by the INTERLEAVE_DETECT bit in the External status register (Table 29).

6.9.8 Loopback modes

The TJA1102A supports three loopback modes:

- Internal loopback (PCS loopback in accordance with IEEE 802.3bw)
- External loopback
- Remote loopback

To run a PHY in loopback mode, the LOOPBACK control bit in the Basic control register should be set before enabling link control.

6.9.8.1 Internal loopback

In Internal loopback mode, the PCS receive function gets the ternary symbols A_n and B_n directly from the PCS transmit function as shown in Figure 12. This action allows the MAC to compare packets sent through the MII transmit function with packets received from the MII receive function and, therefore, to validate the functionality of the 100BASE-T1 PCS function.

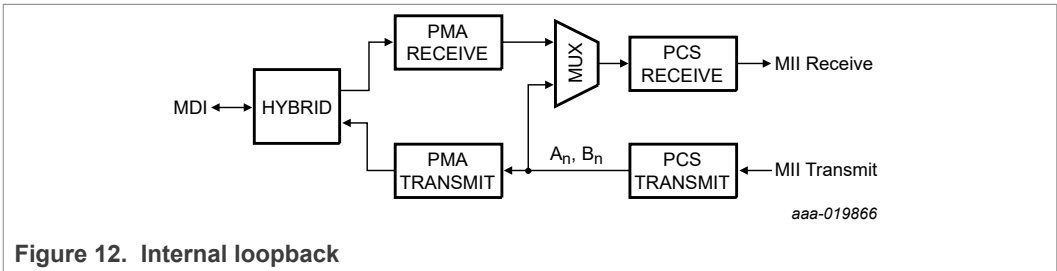

Figure 12. Internal loopback

6.9.8.2 External loopback

In External loopback mode, the PMA receive function receives signals directly from the PMA transmit function as shown in Figure 13. This external loopback test allows the MAC to compare packets sent through the MII transmit function with packets received from the MII receive function and, therefore, to validate the functionality of the 100BASE-T1 PCS and PMA functions.

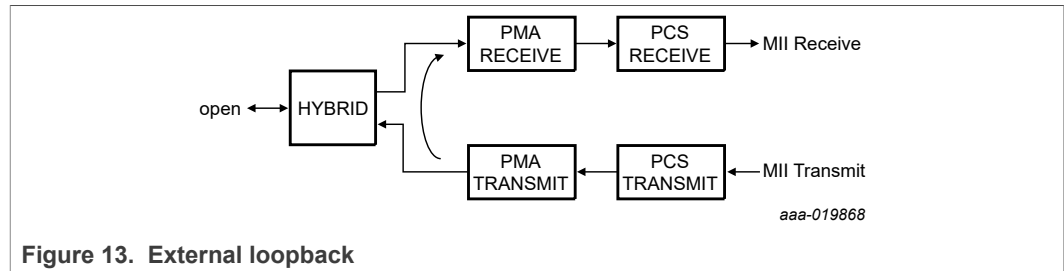

Figure 13. External loopback

6.9.8.3 Remote loopback

In Remote loopback mode, the packet received by the link partner at the MDI is passed through the PMA receive and PCS receive functions and forwarded to the PCS transmit function, which in turn sends it back to the link partner from where it came. The PCS receive data is made available at the MII. Remote loopback allows the MAC to compare the packets sent to the MDI with the packets received back from the MDI and, therefore, to validate the functionality of the physical channel, including both 100BASE-T1 PHYs.

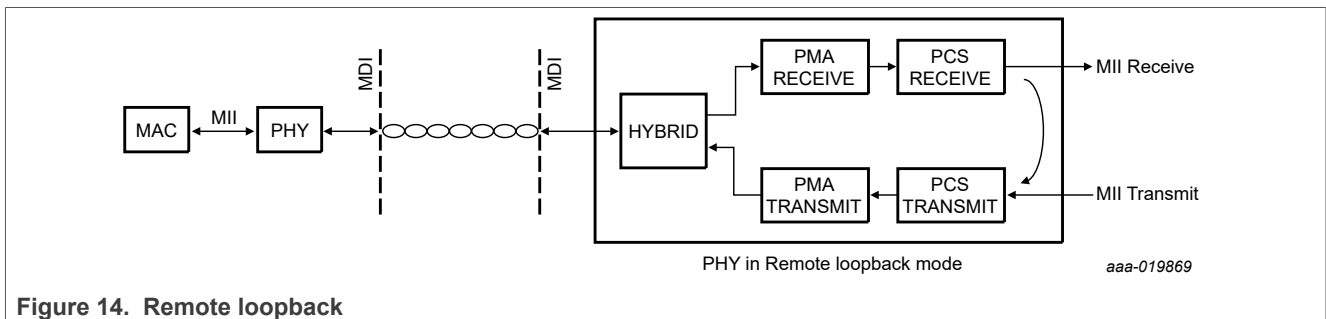

Figure 14. Remote loopback

6.10 Hardware configuration

A number of pins are provided to allow default values for a number of features to be hardware-configured, without microcontroller interaction. The pull-up/down behavior of these pins is sensed at power-up and after a reset. A pull-up behavior is coded as logic 1, while a pull-down behavior is coded as logic 0. The results are stored in the corresponding SMI registers. All pre-configuration settings (except for the PHY addresses) can be overwritten via SMI commands.

Pin strapping at pins 37 (PHYAD3), 36 (PHYAD2) and 35 (PHYAD1) determines bits 3, 2 and 1, respectively, of the PHY address used for the SMI address/Cipher scrambler. The PHY address cannot be changed once the PHY has been configured. Besides the address configured via pin strapping, the TJA1102A can always be accessed via address 0.

Table 12 gives an overview of the functions to be configured via hardware pins.

Table 12. Pin strapping configuration^[1]

Symbol	Pin	Value	Description
MASTER_SLAVE/ PHY_EN	34 (CONFIG3) 33 (CONFIG2) 32 (CONFIG1)	000 ^[2]	P0 disabled, P1 Master
		001	P0 disabled, P1 Slave
		010	P0 Master, P1 disabled
		011	P0 Master, P1 Master
		100	P0 Master, P1 Slave
		101	P0 Slave, P1 disabled
		110	P0 Slave, P1 Master
		111	P0 Slave, P1 Slave
AUTO_OP	55 (CONFIG0)	0	managed operation
		1	autonomous operation
PHYAD[3:1]	37 (PHYAD3)	-	bit 3 of PHY address used for the SMI
	36 (PHYAD2)	-	bit 2 of PHY address used for the SMI
	35 (PHYAD1)	-	bit 1 of PHY address used for the SMI
MII_CONFIG	1 (CONFIG5) 56 (CONFIG4)	00 ^[3]	MII mode enabled for both PHYs (bits MII_MODE in Table 22 set to 00)
		01 ^[4]	RMII mode enabled for both PHYs (bits MII_MODE in Table 22 set to 01 or 10, depending on CLK_MODE)
		10 ^[3]	Reverse MII mode P0; MII mode P1, internal MII (bits MII_MODE in Table 22 set to 11 for P0 and 00 for P1; bit INT_REV_MII in Table 29 set to 1)
		11 ^[3]	Reverse MII mode P0; MII mode P1; external MII; (bits MII_MODE in Table 22 set to 11 for P0 and 00 for P1; bit INT_REV_MII in Table 29 set to 0)
CLK_MODE	3 (CONFIG7) 2 (CONFIG6)	00	25 MHz XTAL; no clock at CLK_IN_OUT
		01	25 MHz XTAL; 25 MHz at CLK_IN_OUT
		10	25 MHz external clock at CLK_IN_OUT
		11	50 MHz input at REF_CLK; RMII mode only; no XTAL; no clock at CLK_IN_OUT
LDO_MODE	15 (SEL_1V8)	0	internal 1.8 V LDO enabled
		1	external 1.8 V supply

[1] Pin strapping functionality relating to PHY1 is not relevant to the TJA1102AS, since P1 is permanently disabled.
 [2] Ordered from MSB to LSB; for value 011 for example, pin 34 = 0, pin 33 = 1 and pin 32 = 1. Note that PHY1 is always disabled in the TJA1102AS, regardless of the value level of on these pins during pin strapping.
 [3] CLK_MODE = 00, 01 or 10.
 [4] All clock modes (CLK_MODE = xx).

6.11 SMI registers

A dedicated register set is provided for each PHY. Some register bits are only valid for block P0 and always return 0 when read from block P1. These bits are indicated in the appropriate tables. Two shared configuration registers are provided to configure common parameters.

Access to the register sets for both PHY blocks on the TJA1102A is provided via the SMI. Which PHY block is selected by an SMI read/write access depends on the PHY address in the SMI frame (read/write access to disabled block P1 is not supported on the TJA1102AS).

6.11.1 Register mapping overview

Copies of the registers listed in [Table 13](#) are provided for each PHY (except for the Common configuration registers which are shared) and are accessible via SMI with the appropriate PHY address.

Table 13. SMI register mapping

Register index (dec)	Register name	Group
0	Basic control register	Basic
1	Basic status register	Basic
2	PHY identification register 1	Extended (P0 only)
3	PHY identification register 2	Extended (P0 only)
15	Extended status register	Extended
16	PHY identification register 3	NXP specific (P0 only)
17	Extended control register	NXP specific
18	Configuration register 1	NXP specific
19	Configuration register 2	NXP specific
20	Symbol error counter register	NXP specific
21	Interrupt source register	NXP specific
22	Interrupt enable register	NXP specific
23	Communication status register	NXP specific
24	General status register	NXP specific
25	External status register	NXP specific
26	Link-fail counter register	NXP specific
27	Common configuration register	NXP specific (P0 only)
28	Configuration register 3	NXP specific

Table 14. Register notation

Notation	Description
R/W	Read/write
R	Read only

Table 14. Register notation...continued

Notation	Description
LH	Latched HIGH; must be read out to reset
LL	Latched LOW; must be read out to reset
SC	Self-clearing
PS	Pin strapping

6.11.2 TJA1102A registers

Table 15. Basic control register (register 0)

Bit	Symbol	Access	Value	Description
15	RESET	R/W SC		software reset control:
			0 ^[1]	normal operation
			1	PHY reset
14	LOOPBACK ^[2]	R/W		loopback control:
			0 ^[1]	normal operation
			1	loopback mode
13	SPEED_SELECT (LSB)	R/W	^[3]	speed select (LSB):
			0	10 Mbit/s if SPEED_SELECT (MSB) = 0 1000 Mbit/s if SPEED_SELECT (MSB) = 1
			1 ^[1]	100 Mbit/s if SPEED_SELECT (MSB) = 0 reserved if SPEED_SELECT (MSB) = 1
12	AUTONEG_EN	R/W SC	0 ^[1]	Auto negotiation not supported; always 0; a write access is ignored.
11	POWER_DOWN	R/W		Standby power down enable:
			0 ^[1]	normal operation (clearing this bit automatically triggers a transition to Normal mode, provided control bits POWER_MODE are set to 0011 Normal mode, see Table 21)
			1	power down and switch to Standby mode (provided ISOLATE = 0; ignored if ISOLATE = 1 and CONTROL_ERR interrupt generated)
10	ISOLATE	R/W		PHY isolation:
			0 ^[1]	normal operation
			1	isolate PHY from MII/RMII (provided POWER_DOWN = 0; ignored if POWER_DOWN = 1 and CONTROL_ERR interrupt generated)
9	RE_AUTONEG	R/W SC	0 ^[1]	Auto negotiation not supported; always 0; a write access is ignored.
8	DUPLEX_MODE	R/W	1 ^[1]	only full duplex supported; always 1; a write access is ignored.
7	COLLISION_TEST	R/W	0 ^[1]	COL signal test not supported; always 0; a write access is ignored.
6	SPEED_SELECT (MSB)	R/W	^[3]	speed select (MSB):

Table 15. Basic control register (register 0)...continued

Bit	Symbol	Access	Value	Description
			0 ^[1]	10 Mbit/s if SPEED_SELECT (LSB) = 0 100 Mbit/s if SPEED_SELECT (LSB) = 1
			1	1000 Mbit/s if SPEED_SELECT (LSB) = 0 reserved if SPEED_SELECT (LSB) = 1
5	UNIDIRECT_EN	R/W		unidirectional enable when bit 12 (AUTONEG_EN) = 0 and bit 8 (DUPLEX_MODE) = 1:
			0 ^[1]	enable transmit from MII only when the PHY has determined that a valid link has been established
			1	enable transmit from MII regardless of whether the PHY has determined that a valid link has been established
4:0	reserved	R/W	00000 ^[1]	always write 00000; ignore on read

[1] Default value.

[2] The loopback mode is selected via bits LOOPBACK_MODE in the Extended control register (Table 21).

[3] Speed Select: 00: 10 Mbit/s; 01: 100 Mbit/s; 10: 1000 Mbit/s; 11: reserved; a write access value other than 01 is ignored.

Table 16. Basic status register (register 1)

Bit	Symbol	Access	Value	Description
15	100BASE-T4	R	0 ^[1]	PHY not able to perform 100BASE-T4
			1	PHY able to perform 100BASE-T4
14	100BASE-X_FD	R	0 ^[1]	PHY not able to perform 100BASE-X full-duplex
			1	PHY able to perform 100BASE-X full-duplex
13	100BASE-X_HD	R	0 ^[1]	PHY not able to perform 100BASE-X half-duplex
			1	PHY able to perform 100BASE-X half-duplex
12	10Mbps_FD	R	0 ^[1]	PHY not able to perform 10 Mbit/s full-duplex
			1	PHY able to perform 10 Mbit/s full-duplex
11	10Mbps_HD	R	0 ^[1]	PHY not able to perform 10 Mbit/s half-duplex
			1	PHY able to perform 10 Mbit/s half-duplex
10	100BASE-T2_FD	R	0 ^[1]	PHY not able to perform 100BASE-T2 full-duplex
			1	PHY able to perform 100BASE-T2 full-duplex
9	100BASE-T2_HD	R	0 ^[1]	PHY not able to perform 100BASE-T2 half-duplex
			1	PHY able to perform 100BASE-T2 half-duplex
8	EXTENDED_STATUS	R	0	no extended status information in register 15h
			1 ^[1]	extended status information in register 15h
7	UNIDIRECT_ABILITY	R	0	PHY able to transmit from MII only when the PHY has determined that a valid link has been established
			1 ^[1]	PHY able to transmit from MII regardless of whether the PHY has determined that a valid link has been established
6	MF_PREAMBLE_SUPPRESSION	R	0	PHY will not accept management frames with preamble suppressed

Table 16. Basic status register (register 1)...continued

Bit	Symbol	Access	Value	Description
			1 ^[1]	PHY will accept management frames with preamble suppressed
5	AUTONEG_COMPLETE	R	0	Autonegotiation process not completed
			1 ^[1]	Autonegotiation process completed
4	REMOTE_FAULT	R LH	0 ^{[1][2]}	no remote fault condition detected
			1	remote fault condition detected
3	AUTONEG_ABILITY	R	0 ^[1]	PHY not able to perform Autonegotiation
			1	PHY able to perform Autonegotiation
2	LINK_STATUS	R LL	0 ^{[1][2][3]}	link is down
			1	link is up
1	JABBER_DETECT	R LH	0 ^{[1][2]}	no jabber condition detected
			1	jabber condition detected
0	EXTENDED_CAPABILITY	R	0	basic register set capabilities only
			1 ^[1]	extended register capabilities

[1] Default value.

[2] Reset to default value when link control is disabled (LINK_CONTROL = 0).

[3] According to IEEE 802.3; LINK_STATUS = 1 when LOC_RCVR_STATUS = 1.

Table 17. PHY identification register 1 (register 2)

Bit	Symbol	Access	Value	Description
15:0	PHY_ID	R	0180h ^[1]	bits 3 to 18 of the Organizationally Unique Identifier (OUI) ^[2]

[1] Default value (PHY0 only in dual PHY variant; returns all 0s for PHY1).

[2] OUI = 00.60.37h (PHY0 only in dual PHY variant; returns all 0s for PHY1).

Table 18. PHY identification register 2 (register 3)

Bit	Symbol	Access	Value	Description
15:10	PHY_ID	R	110111 ^[1]	bits 19 to 24 of the OUI ^[2]
9:4	TYPE_NO	R	001000 ^[3]	six-bit manufacturer's type number
			001001 ^[4]	
3:0	REVISION_NO	R	0010 ^[1]	four-bit manufacturer's revision number

[1] Default value (PHY0 only in dual-PHY variant; returns all 0s for PHY1).

[2] OUI = 00.60.37h (PHY0 only in dual-PHY variant; returns all 0s for PHY1).

[3] Default value for TJA1102A dual-PHY variant (PHY0 only; returns all 0s for PHY1).

[4] Default value for TJA1102AS.

Table 19. PHY identification register 3 (Register 16)

Bit	Symbol	Access	Value	Description
15:8	reserved	R	-	

Table 19. PHY identification register 3 (Register 16)...continued

Bit	Symbol	Access	Value	Description
7:0	VERSION_NO	R	xxh ^[1]	8-bit manufacturer's firmware revision number

[1] Default value (PHY0 only in dual-PHY variant; returns all 0s for PHY1).

Table 20. Extended status register (register 15)

Bit	Symbol	Access	Value	Description
15	1000BASE-X_FD	R	0 ^[1]	PHY not able to perform 1000BASE-X full-duplex
			1	PHY able to perform 1000BASE-X full-duplex
14	1000BASE-X_HD	R	0 ^[1]	PHY not able to perform 1000BASE-X half-duplex
			1	PHY able to perform 1000BASE-X half-duplex
13	1000BASE-T_FD	R	0 ^[1]	PHY not able to perform 1000BASE-T full-duplex
			1	PHY able to perform 1000BASE-T full-duplex
12	1000BASE-T_HD	R	0 ^[1]	PHY not able to perform 1000BASE-T half-duplex
			1	PHY able to perform 1000BASE-T half-duplex
11:8	reserved	R	0000 ^[1]	always 0000; ignore on read
7	100BASE-T1	R	0	PHY not able to 1-pair 100BASE-T1 100 Mbit/s
			1 ^[1]	PHY able to 1-pair 100BASE-T1 100 Mbit/s
6	1000BASE-RTPGE	R	0 ^[1]	PHY not able to support RTPGE
			1	PHY supports RTPGE
5:0	reserved	R	-	ignore on read

[1] Default value.

Table 21. Extended control register (register 17)

Bit	Symbol	Access	Value	Description
15	LINK_CONTROL	R/W	^[1]	link control enable:
			0	link control disabled
			1	link control enabled
14:11	POWER_MODE	R/W	^[2]	operating mode select:
			0000 ^[3]	no change
			0011	Normal mode (command)
			1001	Silent mode (read only)
			1010	Sleep mode (read only)
			1011	Sleep Request mode (command)
			1100	Standby mode (command)
10	SLAVE_JITTER_TEST ^[4]	R/W		enable/disable Slave jitter test
			0 ^[3]	disable Slave jitter test

Table 21. Extended control register (register 17)...continued

Bit	Symbol	Access	Value	Description
			1	enable Slave jitter test
9	TRAINING_RESTART	R/W SC		Autonegotiation process restart:
			0 ^[3]	halts the training phase
			1	forces a restart of the training phase
8:6	TEST_MODE ^[4]	R/W		test mode selection:
			000 ^[3]	no test mode
			001	100BASE-T1 test mode 1
			010	100BASE-T1 test mode 2
			011	test mode 3
			100	100BASE-T1 test mode 4
			101	100BASE-T1 test mode 5
			110	scrambler and descrambler bypassed
			111	reserved; ignore on read
5	CABLE_TEST	R/W SC		TDR-based cable test:
			0 ^[3]	stops TDR-based cable test
			1	forces TDR-based cable test
4:3	LOOPBACK_MODE ^{[4][5]}	R/W		loopback mode select:
			00 ^[3]	internal loopback
			01	external loopback
			10	external loopback
			11	remote loopback
2	CONFIG_EN	R/W	^[3]	configuration register access:
			0 ^[3]	configuration register access disabled
			1	configuration register access enabled
1	reserved	R/W	-	ignore on read
0	WAKE_REQUEST	SC		wake-up request configuration:
			0 ^[3]	no wake-up signal to be transmitted
			1	LINK_CONTROL = 0: transmit idle symbols as bus wake-up request LINK_CONTROL = 1: transmit WUR symbols

[1] Default value is 0 when AUTO_OP = 0; default value is 1 when AUTO_OP = 1.

[2] Any other value generates a CONTROL_ERR interrupt.

[3] Default value.

[4] Link control must be disabled (LINK_CONTROL = 0) before entering this mode.

[5] The selected loopback mode is enabled when bit LOOPBACK in the Basic control register (Table 15) is set to 1.

Table 22. Configuration register 1 (register 18)

Bit	Symbol	Access	Value	Description
15	MASTER_SLAVE	R/W	^[1]	PHY Master/Slave configuration:
			0	PHY configured as Slave
			1	PHY configured as Master
14	FWDPHYLOC	R/W	^[2]	local wake-up forwarding:
			0	wake-up event not forwarded locally
			1 ^[3]	wake-up event forwarded locally
13:12	reserved	R/W	-	ignore on read
11	REMWUPHY	R/W	^[2]	remote wake-up:
			0	PHY does not react to a remote wake-up
			1 ^[3]	PHY reacts to a remote wake-up
10	LOCWUPHY	R/W	^[2] ^[4]	local wake-up:
			0	PHY does not react to a local wake-up
			1 ^[3]	PHY reacts to a local wake-up
9:8	MII_MODE	R/W	^[1]	MII mode:
			00	MII mode enabled
			01	RMII mode enabled (50 MHz input on Px_REF_CLK)
			10	RMII mode enabled (25 MHz XTAL output on Px_REF_CLK)
			11	Reverse MII mode
7	MII_DRIVER	R/W		MII output driver strength:
			0 ^[3]	standard
			1	reduced
6	SLEEP_CONFIRM	R/W		sleep confirmation setting:
			0 ^[3]	no confirmation needed from another PHY before going to sleep
			1	confirmation needed from another PHY before going to sleep
5	LPS_WUR_DIS	R/W		LPS/WUR setting:
			0 ^[3]	LPS/WUR enabled
			1	LPS/WUR disabled
4	SLEEP_ACK	R/W		sleep acknowledge:
			0 ^[3]	sleep acknowledge timer disabled; auto-transition back from Sleep Request mode to Normal mode enabled during data transmission on MII or MDI
			1	sleep acknowledge timer enabled; auto-transition back from Sleep Request mode to Normal mode disabled during data transmission on MII or MDI
3	reserved	R/W	-	ignore on read
2	FWDPHYREM	R/W	^[2]	remote wake-up forwarding:
			0 ^[3]	remote wake-up event not forwarded

Table 22. Configuration register 1 (register 18)...continued

Bit	Symbol	Access	Value	Description
			1	remote wake-up event forwarded
1	AUTO_PWD	R/W		autonomous power down:
			0 ^[3]	autonomous power-down disabled
			1	autonomous power-down enabled
0	LPS_ACTIVE	R/W		LPS code group reception:
			0	automatic transition from Normal to Sleep Request when LPS code group received disabled
			1 ^[3]	automatic transition from Normal to Sleep Request when LPS code group received enabled

[1] Default value determined by pin strapping (see [Section 6.10](#)).

[2] Clear bits FWDPHYLOC, REMWUPHY, LOCWUPHY and FWDPHYREM if the corresponding wake-up/forwarding feature is not being used.

[3] Default value.

[4] Setting LOCWUPHY has an activation time of $t_{det(wake)}$. If a wake-up occurs within the activation time, it may not be detected.

Table 23. Configuration register 2 (register 19)

Bit	Symbol	Access	Value	Description
15:11	PHYAD[4:0]	R	^[1]	PHY address used for the SMI address and for initializing the Cipher scrambler key: PHYAD[4] is set to 0 PHYAD[3:1] is predetermined by the hardware configuration straps on pins 37, 36 and 35 respectively PHYAD[0] set to 0 for P0 and 1 for P1
10:9	SQI_AVERAGING	R/W	^[2]	Signal Quality Indicator (SQI) averaging:
			00	SQI averaged 32 symbols
			01 ^[3]	SQI averaged 64 symbols
			10	SQI averaged 128 symbols
			11	SQI averaged 256 symbols
8:6	SQI_WLIMIT	R/W		SQI warning limit:
			000	no warning limit
			001 ^[3]	class A SQI warning limit
			010	class B SQI warning limit
			011	class C SQI warning limit
			100	class D SQI warning limit
			101	class E SQI warning limit
			110	class F SQI warning limit
5:3	SQI_FAILLIMIT	R/W		SQI fail limit:
			000 ^[3]	no fail limit
			001	class A SQI fail limit

Table 23. Configuration register 2 (register 19)...continued

Bit	Symbol	Access	Value	Description
			010	class B SQI fail limit
			011	class C SQI fail limit
			100	class D SQI fail limit
			101	class E SQI fail limit
			110	class F SQI fail limit
			111	class G SQI fail limit
2	JUMBO_ENABLE	R/W		Jumbo packet support:
			0	packets up to 4 kB supported
			1 ^[3]	packets up to 16 kB supported
1:0	SLEEP_REQUEST_TO	R/W	[4]	sleep request/acknowledge timeout:
			00	0.4 ms/0.2 ms
			01 ^[3]	1 ms/0.5 ms
			10	4 ms/2 ms
			11	16 ms/8 ms

[1] Default value determined by pin strapping (see [Section 6.10](#)).

[2] The SQI is derived from the actual internal slicer margin and includes filtering. Averaging the SQI value itself does not, therefore, have any added value.

[3] Default value.

[4] The specified values are nominal settings; see parameters $t_{to(req)sleep}$ and $t_{to(ack)sleep}$, respectively, for the limits.

Table 24. Symbol error counter register (register 20)

Bit	Symbol	Access	Value	Description
15:0	SYM_ERR_CNT	R	0000h ^[1]	The symbol error counter is incremented when an invalid code symbol is received (including idle symbols). The counter is incremented only once per packet, even when the received packet contains more than one symbol error. This counter increments up to 2^{16} . When the counter overflows, the value FFFFh is retained. The counter is reset when the register is read.

[1] Default value. Bits NOT reset to default value when link control is disabled (LINK_CONTROL = 0).

Table 25. Interrupt source register (register 21)

Bit	Symbol	Access	Value	Description
15	PWON	R LH	0 ^[1]	power-on not detected
			1	power-on detected
14	WAKEUP	R LH	0 ^{[2][3]}	no local or remote wake-up detected
			1	local or remote wake-up detected
13	WUR_RECEIVED	R LH	0 ^[2]	no dedicated wake-up request detected
			1	dedicated wake-up request detected

Table 25. Interrupt source register (register 21)...continued

Bit	Symbol	Access	Value	Description
12	LPS_RECEIVED	R LH	0 ^[2]	no LPS code groups received
			1	LPS code groups received
11	PHY_INIT_FAIL	R LH	0 ^[2]	no PHY initialization error detected
			1	PHY initialization error detected
10	LINK_STATUS_FAIL	R LH	0 ^{[2][4]}	link status not changed
			1	link status bit LINK_UP changed from 'link OK' to 'link fail'
9	LINK_STATUS_UP	R LH	0 ^{[2][4]}	link status not changed
			1	link status bit LINK_UP changed from 'link fail' to 'link OK'
8	SYM_ERR	R LH	0 ^{[2][4]}	no symbol error detected
			1	symbol error detected
7	TRAINING_FAILED	R LH	0 ^[2]	no training phase failure detected
			1	training phase failure detected
6	SQI_WARNING	R LH	0 ^{[2][4]}	SQI value above warning limit
			1	SQI value below warning limit and bit LINK_UP set
5	CONTROL_ERR	R LH	0 ^[2]	no SMI control error detected
			1	SMI control error detected
4	reserved	R	-	ignore on read
3	UV_ERR	R LH	0 ^[1]	no undervoltage detected
			1	undervoltage detected on V _{DD(I/O)} , V _{DDD(3V3)} , V _{DDD(1V8)} or V _{DDA(3V3)}
2	UV_RECOVERY	R LH	0 ^[1]	no undervoltage recovery detected
			1	undervoltage recovery detected
1	TEMP_ERR	R LH	0 ^[1]	no overtemperature error detected
			1	overtemperature error detected
0	SLEEP_ABORT	R LH	0 ^[2]	no transition from Sleep Request back to Normal as a result of the Sleep Request timer expiring
			1	transition from Sleep Request back to Normal as a result of the Sleep Request timer expiring

[1] Default value (P0 only; always returns 0 for P1 block).

[2] Default value.

[3] Bit WAKEUP may be set when an undervoltage is detected on V_{DD(I/O)} in Sleep_Request mode. Ignore this bit when bit UV_VDDIO is set. Bit WAKEUP is reset by a read operation; however wake-up detection will not be enabled again until a state transition has been completed.

[4] Interrupts LINK_STATUS_FAIL, LINK_STATUS_UP, SYM_ERR and SQI_WARNING are cleared on entering Sleep Request mode, on entering Standby mode due to an undervoltage and when an undervoltage is detected in Standby mode.

Table 26. Interrupt enable register (register 22)

Disabling an interrupt source disables signaling at pin INT_N for that interrupt. However, the corresponding bit in the Interrupt source register (Table 25) remains active.

Bit	Symbol	Access	Value	Description
15	PWON_EN	R/W	0 ^[1]	PWON interrupt disabled

Table 26. Interrupt enable register (register 22)...continued

Disabling an interrupt source disables signaling at pin INT_N for that interrupt. However, the corresponding bit in the Interrupt source register (Table 25) remains active.

Bit	Symbol	Access	Value	Description
			1 ^[1]	PWON interrupt enabled
14	WAKEUP_EN	R/W	0 ^[2]	WAKEUP interrupt disabled
			1	WAKEUP interrupt enabled
13	WUR_RECEIVED_EN	R/W	0 ^[2]	WUR_RECEIVED interrupt disabled
			1	WUR_RECEIVED interrupt enabled
12	LPS_RECEIVED_EN	R/W	0 ^[2]	LPS_RECEIVED interrupt disabled
			1	LPS_RECEIVED interrupt enabled
11	PHY_INIT_FAIL_EN	R/W	0 ^[2]	PHY_INIT_FAIL interrupt disabled
			1	PHY_INIT_FAIL interrupt enabled
10	LINK_STATUS_FAIL_EN	R/W	0 ^[2]	LINK_STATUS_FAIL interrupt disabled
			1	LINK_STATUS_FAIL interrupt enabled
9	LINK_STATUS_UP_EN	R/W	0 ^[2]	LINK_STATUS_UP interrupt disabled
			1	LINK_STATUS_UP interrupt enabled
8	SYM_ERR_EN	R/W	0 ^[2]	SYM_ERR interrupt disabled
			1	SYM_ERR interrupt enabled
7	TRAINING_FAILED_EN	R/W	0 ^[2]	TRAINING_FAILED interrupt disabled
			1	TRAINING_FAILED interrupt enabled
6	SQI_WARNING_EN	R/W	0 ^[2]	SQI_WARNING interrupt disabled
			1	SQI_WARNING interrupt enabled
5	CONTROL_ERR_EN	R/W	0 ^[2]	CONTROL_ERR interrupt disabled
			1	CONTROL_ERR interrupt enabled
4	reserved	R/W	0 ^[2]	always write 0; ignore on read
3	UV_ERR_EN	R/W	0 ^[2]	UV_ERR interrupt disabled
			1	UV_ERR interrupt enabled
2	UV_RECOVERY_EN	R/W	0 ^[2]	UV_RECOVERY interrupt disabled
			1	UV_RECOVERY interrupt enabled
1	TEMP_ERR_EN	R/W	0 ^[2]	TEMP_ERR interrupt disabled
			1	TEMP_ERR interrupt enabled
0	SLEEP_ABORT_EN	R/W	0 ^[2]	SLEEP_ABORT interrupt disabled
			1	SLEEP_ABORT interrupt enabled

[1] Default value is 1 for block P0 and 0 for block P1 (TJA1102A).

[2] Default value.

Table 27. Communication status register (register 23)

Bit	Symbol	Access	Value	Description
15	LINK_UP	R	0 ^{[1][2]}	link failure
			1	link OK
14:13	TX_MODE	R	00 ^{[1][2]}	transmitter disabled
			01	transmitter in SEND_N mode
			10	transmitter in SEND_I mode
			11	transmitter in SEND_Z mode
12	LOC_RCVR_STATUS	R LL	0 ^{[1][2]}	local receiver not OK
			1	local receiver OK
11	REM_RCVR_STATUS	R LL	0 ^{[1][2]}	remote receiver not OK
			1	remote receiver OK
10	SCR_LOCKED	R	0 ^{[1][2]}	descrambler unlocked
			1	descrambler locked
9	SSD_ERR	R LH	0 ^{[1][2]}	no SSD error detected
			1	SSD error detected
8	ESD_ERR	R LH	0 ^{[1][2]}	no ESD error detected
			1	ESD error detected
7:5	SQI	R	000 ^{[1][2]}	worse than class A SQI (unstable link)
			001	class A SQI (unstable link)
			010	class B SQI (unstable link)
			011	class C SQI (good link)
			100	class D SQI (good link; bit error rate < 1e-10)
			101	class E SQI (good link)
			110	class F SQI (very good link)
			111	class G SQI (very good link)
4	RECEIVE_ERR	R LH	0 ^{[1][2]}	no receive error detected
			0	receive error detected since register last read
3	TRANSMIT_ERR	R LH	0 ^{[1][2]}	no transmit error detected
			1	transmit error detected since register last read
2:0	PHY_STATE	R	000 ^[1]	PHY Idle
			001	PHY Initializing
			010	PHY Configured
			011	PHY Offline
			100	PHY Active
			101	PHY Isolate
			110	PHY Cable test
			111	PHY Test mode

- [1] Default value.
 [2] Reset to default value when link control is disabled (LINK_CONTROL = 0).

Table 28. General status register (register 24)

Bit	Symbol	Access	Value	Description
15	INT_STATUS	R	0 ^[1]	all interrupts cleared
			1	unmasked interrupt pending
14	PLL_LOCKED	R LL	0 ^[1]	PLL unstable and not locked
			1	PLL stable and locked
13	LOCAL_WU	R LH	0 ^{[1][2]}	no local wake-up detected
			1	local wake-up detected
12	REMOTE_WU	R LH	0 ^{[1][2]}	no remote wake-up detected
			1	remote wake-up detected
11	DATA_DET_WU	R LH	0 ^{[1][3]}	no 100BASE-T1 data detected at MDI or MII in Sleep Request mode
			1	100BASE-T1 data detected at MDI (pcs_rx_dv = TRUE; see [1]) or MII (TXEN = 1) in Sleep Request mode
10	EN_STATUS	R LH	0 ^[4]	EN HIGH
			1	EN switched LOW since register last read
9	RESET_STATUS	R LH	0 ^[4]	no hardware reset detected
			1	hardware reset detected since register last read
8	reserved	R	-	ignore on read
7:3	LINKFAIL_CNT	R	0000 ^{[1][5]}	number of link fails since register last read
2:0	reserved	R	-	ignore on read

- [1] Default value.
 [2] Status bit is cleared by a read operation; however wake-up detection will not be enabled again until a state transition has been completed.
 [3] Bit DATA_DET_WU may be set when an undervoltage is detected on V_{DD(I0)} in Sleep_Request mode. Ignore this bit when bit UV_VDDIO is set.
 [4] Default value (P0 only; always returns 0 for P1 block).
 [5] Bits NOT reset to default value when link control is disabled (LINK_CONTROL = 0).

Table 29. External status register (register 25)

Bit	Symbol	Access	Value	Description
15	UV_VDDD_3V3	R LH	0 ^[1]	no undervoltage detected on pin V _{DDD(3V3)}
			1	undervoltage detected on pin V _{DDD(3V3)}
14	UV_VDDA_3V3	R LH	0 ^[1]	no undervoltage detected on pin V _{DDA(3V3)}
			1	undervoltage detected on pin V _{DDA(3V3)}
13	UV_VDDD_1V8	R LH	0 ^[1]	no undervoltage detected on pin V _{DDD(1V8)}
			1	undervoltage detected on pin V _{DDD(1V8)}
12	reserved	R	-	ignore on read
11	UV_VDDIO	R LH	0 ^[1]	no undervoltage detected on pin V _{DD(I0)}
			1	undervoltage detected on pin V _{DD(I0)}

Table 29. External status register (register 25)...continued

Bit	Symbol	Access	Value	Description
10	TEMP_HIGH	R LH	0 ^[1]	temperature below high level
			1	temperature above high level
9	TEMP_WARN	R LH	0 ^[1]	temperature below warning level
			1	temperature above warning level
8	SHORT_DETECT	R LH	0 ^[2]	no short circuit detected
			1	short circuit detected since register last read
7	OPEN_DETECT	R LH	0 ^[2]	no open circuit detected
			1	open circuit detected since register last read
6	POLARITY_DETECT	R	0 ^[2]	no polarity inversion detected at MDI
			1	polarity inversion detected at MDI
5	INTERLEAVE_DETECT	R	0 ^[2]	interleave order of detected ternary symbols: TAn, TBn
			1	interleave order of detected ternary symbols: TBn, TAn
4:0	reserved	R	-	ignore on read

[1] Default value (P0 only; always returns 0 for P1 block).

[2] Default value; bit NOT reset to default value when link control is disabled (LINK_CONTROL = 0).

Table 30. Link fail counter register (register 26)

Bit	Symbol	Access	Value	Description
15:8	LOC_RCVR_CNT	R	00h ^{[1][2]}	The counter is incremented when local receiver is NOT_OK; when the counter overflows, the value FFh is retained. The counter is reset when the register is read.
7:0	REM_RCVR_CNT	R	00h ^{[1][2]}	The counter is incremented when remote receiver is NOT_OK; when the counter overflows, the value FFh is retained. The counter is reset when the register is read.

[1] Default value.

[2] Bits NOT reset to default value when link control is disabled (LINK_CONTROL = 0).

Table 31. Common configuration register (register 27)^[1]

Bit	Symbol	Access	Value	Description
15	AUTO_OP	R/W	^[2]	managed/autonomous operation:
			0	managed operation
			1	autonomous operation
14	INT_REV_MII	R/W	^[2]	PHY Master/Slave configuration (P0 in Reverse MII mode; P1 in MII mode)
			0	P1 must be connected externally to P0 (external PHY must be connected to P0 in the TJA1102AS)
			1	P1 connected internally to P0 (TJA1102A)
13:12	CLK_MODE	R/W	^[2]	clock mode:

Table 31. Common configuration register (register 27)^[1] ...continued

Bit	Symbol	Access	Value	Description
			00	25 MHz XTAL; no clock at CLK_IN_OUT
			01	25 MHz XTAL; 25 MHz output at CLK_IN_OUT
			10	25 MHz external clock at CLK_IN_OUT
			11	50 MHz input at REF_CLK; RMI mode only; no XTAL; no clock at CLK_IN_OUT
11	LDO_MODE	R/W	^[2]	LDO mode:
			0	internal 1.8 V LDO enabled
			1	external 1.8 V supply
10	CLK_DRIVER	R/W		output driver strength on CLK_IN_OUT:
			0 ^[3]	standard output driver strength at output of CLK_IN_OUT
			1	reduced output driver strength at output of CLK_IN_OUT
9	CLK_HOLD	R/W		local wake-up:
			0 ^[3]	XTAL and CLK_IN_OUT output switched off when not needed by P0 and P1
			1	XTAL and CLK_IN_OUT output remain active until device switched to Sleep mode via SMI
8:7	LOC_WU_TIM	R/W		local wake-up timer:
			00 ^[3]	longest (10 ms to 20 ms)
			01	long (250 μ s to 500 μ s)
			10	short (100 μ s to 200 μ s)
			11	shortest (10 μ s to 40 μ s)
6	CONFIG_WAKE	R/W		local wake configuration:
			0	absolute input threshold
			1 ^[3]	ratiometric input threshold ($V_{DD(I/O)}$)
5	CONFIG_INH	R/W		INH configuration:
			0 ^[3]	INH switched off in Disable mode
			1	INH switched on in Disable mode
4:0	reserved	R/W	-	ignore on read

[1] Read/write operations valid for P0 only (read operation always returns 0 for P1 block).

[2] Default value determined by pin strapping (see [Section 6.10](#)).

[3] Default value.

Table 32. Configuration register 3 (register 28)

Bit	Symbol	Access	Value	Description
15:3	reserved	R/W	-	

Table 32. Configuration register 3 (register 28)...continued

Bit	Symbol	Access	Value	Description
2	MDI_POL	R/W		MDI polarity:
			0 ^[1]	regular polarity: pin 17 = P0_TRX_P; pin 18 = P0_TRX_M pin 25 = P1_TRX_P; pin 24 = P1_TRX_M
			1	swapped polarity: pin 17 = P0_TRX_M; pin 18 = P0_TRX_P pin 25 = P1_TRX_M; pin 24 = P1_TRX_P
1	FORCE_SLEEP	R/W SC		forced sleep operation:
			0 ^[2]	forced sleep inactive
			1	force both PHYs to Sleep mode and device to system sleep
0	PHY_EN	R/W	^[3]	PHY enable:
			0	PHY disabled
			1	PHY enabled

[1] Default value.

[2] Default value (P0 only; always returns 0 for P1 block).

[3] Default value determined by pin strapping (see [Section 6.10](#)).

7 Limiting values

Table 33. Limiting values

In accordance with the Absolute Maximum Rating System (IEC 60134). All voltages are referenced to GND.

Symbol	Parameter	Conditions	Min	Max	Unit
V _x	voltage on pin x ^[1]	on pin V _{BAT}	-0.3	+40	V
		on pin INH	-0.3	V _{BAT} + 0.3	V
		on pin WAKE_IN_OUT	-36	+42	V
		on pins V _{DDA(3V3)} , P0_V _{DDA(TX)} , P1_V _{DDA(TX)} , V _{DDD(3V3)} , V _{DD(IO)} , P0_TRX_P, P0_TRX_M, P1_TRX_P, P1_TRX_M	-0.3	+4.6	V
		on pins V _{DD(1V8)} , XI, XO	-0.3	+2.5	V
		on input pins MDC, MDIO, RST_N, INT_N, EN, CLK_IN_OUT, SEL_1V8 and MII digital input pins	-0.3	min(V _{DD(IO)} + 0.3, +4.6)	V
		on digital output pins	-0.3	V _{DD(IO)} + 0.3	V
I _{O(INH)}	output current on pin INH		-2	-	mA
V _{trt}	transient voltage	on pins WAKE_IN_OUT, V _{BAT} , P0_TRX_P, P0_TRX_M, P1_TRX_P, P1_TRX_M ^[2]			
		pulse 1	-100	-	V
		pulse 2a	-	75	V
		pulse 3a	-150	-	V
		pulse 3b	-	100	V
V _{ESD}	electrostatic discharge voltage	IEC 61000-4-2; 150 pF, 330 Ω ^[3]			
		on pins P0_TRX_P, P0_TRX_M, P1_TRX_P, P1_TRX_M ^[4]	-8.0	+8.0	kV
		on pin WAKE_IN_OUT ^[5]	-8.0	+8.0	kV
		on pin V _{BAT} to GND ^[6]	-8.0	+8.0	kV
		Human Body Model (HBM)			
		on any pin ^[7]	-2.0	+2.0	kV
		on pins P0_TRX_P, P0_TRX_M, P1_TRX_P, P1_TRX_M	-6.0	+6.0	kV
		on pin WAKE_IN_OUT ^[8]	-6.0	+6.0	kV
		on pin V _{BAT} ^[9]	-6.0	+6.0	kV
		Charged Device Model (CDM)			
on any pin ^[10]	-500	+500	V		
T _{amb}	ambient temperature		-40	+125	°C
T _{stg}	storage temperature		-55	+150	°C

[1] The device can sustain voltages up to the specified values over the product lifetime, provided applied voltages (including transients) never exceed these values.

[2] Verified by an external test house according to IEC TS 62228, Section 4.2.4; parameters for standard pulses defined in ISO7637.

[3] Verified by an external test house according to IEC TS 62228, Section 4.3.

[4] Tested with a common mode choke and 100 nF coupling capacitors.

- [5] Tested with 10 nF capacitor to GND and 10 kΩ in series between the capacitor and the WAKE_IN_OUT pin.
- [6] Tested with 100 nF capacitor from V_{BAT} to GND.
- [7] According to AEC-Q100-002.
- [8] With 10 nF capacitor to GND and 10 kΩ in series between the capacitor and the WAKE_IN_OUT pin.
- [9] With 100 nF from V_{BAT} to GND.
- [10] According to AEC-Q100-011.

8 Thermal characteristics

Table 34. Thermal characteristics

Symbol	Parameter	Conditions	Typ	Unit
R _{th(j-a)}	thermal resistance from junction to ambient	[1] HVQFN56 package; in free air		
		LDO disabled (LDO_MODE = 1)	26	K/W
		LDO enabled (LDO_MODE = 0)	31	K/W
R _{th(j-c)}	thermal resistance from junction to case	[2] HVQFN56 package; in free air		
		LDO disabled (LDO_MODE = 1)	3	K/W
		LDO enabled (LDO_MODE = 0)	8	K/W
Ψ _{j-top}	thermal characterization parameter from junction to top of package	[1] HVQFN36 package; in free air		
		LDO disabled (LDO_MODE = 1)	1	K/W
		LDO enabled (LDO_MODE = 0)	6	K/W

- [1] According to JEDEC JESD51-2, JESD51-5 and JESD51-7 at natural convection on 2s2p board. Board with two inner copper layers(thickness: 35 μm) and thermal via array under the exposed pad connected to the first inner copper layer.
- [2] Determined using an isothermal cold plate.

9 Static characteristics

Table 35. Supply characteristics

T_{vj} = -40 °C to +150 °C; V_{DD(I/O)} = 2.9 V to 3.5 V; V_{BAT} = 2.8 V to 40 V; V_{DDA(3V3)} = V_{DDA(TX)} = V_{DDD(3V3)} = 2.9 V to 3.5 V; all voltages are defined with respect to ground unless otherwise specified; positive currents flow into the IC.

Symbol	Parameter	Conditions	Min	Typ	Max	Unit
Battery supply: pin V _{BAT}						
V _{BAT}	battery supply voltage	operating range	3.1	-	36	V
V _{uvd}	undervoltage detection voltage		2.8	-	-	V
V _{uvr}	undervoltage recovery voltage		-	-	3.1	V
V _{uvhys}	undervoltage hysteresis voltage		15	100	-	mV
I _{BAT}	battery supply current	TJA1102A; all modes except Sleep; V _{BAT} < 36 V; I _{INH} = 0 μA	-	-	2.7	mA
		TJA1102AS; all modes except Sleep; V _{BAT} < 36 V; I _{INH} = 0 μA	-	-	1.7	mA
		Sleep mode; T _{vj} ≤ 85 °C; V _{BAT} < 7.4 V	-	150	300	μA
		Sleep mode; T _{vj} ≤ 85 °C; 7.4 V < V _{BAT} < 30 V	-	45	100	μA
		V _{BAT} < 40 V; I _{INH} = 0 μA	-	-	6.5	mA

Table 35. Supply characteristics...continued

T_{vj} = -40 °C to +150 °C; $V_{DD(I/O)}$ = 2.9 V to 3.5 V; V_{BAT} = 2.8 V to 40 V; $V_{DDA(3V3)} = V_{DDA(TX)} = V_{DDD(3V3)} = 2.9$ V to 3.5 V; all voltages are defined with respect to ground unless otherwise specified; positive currents flow into the IC.

Symbol	Parameter	Conditions	Min	Typ	Max	Unit
3.3 V analog supply: pin $V_{DDA(3V3)}$						
$V_{DDA(3V3)}$	analog supply voltage (3.3 V)	operating range	3.1	3.3	3.5	V
V_{uvd}	undervoltage detection voltage		2.9	-	-	V
V_{uvr}	undervoltage recovery voltage		-	-	3.1	V
V_{uvhys}	undervoltage hysteresis voltage		50	80	-	mV
$I_{DDA(3V3)}$	analog supply current (3.3 V)	TJA1102A; Normal/Sleep Request modes	-	43	55	mA
		TJA1102AS; Normal/Sleep Request modes	-	22	27	mA
		Standby mode	-	130	250	μA
		Disable/Reset modes	-	4	50	μA
3.3 V digital supply: pin $V_{DDD(3V3)}$						
$V_{DDD(3V3)}$	digital supply voltage (3.3 V)	operating range	3.1	3.3	3.5	V
V_{uvd}	undervoltage detection voltage		2.9	-	-	V
V_{uvr}	undervoltage recovery voltage		-	-	3.1	V
V_{uvhys}	undervoltage hysteresis voltage		50	80	-	mV
$I_{DDD(3V3)}$	digital supply current (3.3 V)	TJA1102A; Normal/Sleep Request modes; LDO_MODE = 0	-	100	120	mA
		TJA1102AS; Normal/Sleep Request modes; LDO_MODE = 0	-	51	61	mA
		TJA1102A; Normal/Sleep Request modes; LDO_MODE = 1	-	5	8	mA
		TJA1102AS; Normal/Sleep Request modes; LDO_MODE = 1	-	2.5	4	mA
		Standby mode; LDO_MODE = 0	-	0.2	10	mA
		Disable/Reset modes	-	1	50	μA
1.8 V digital supply: pin $V_{DDD(1V8)}$						
$V_{DDD(1V8)}$	digital supply voltage (1.8 V)	operating range; LDO_MODE = 1	1.745	1.84	1.95	V
V_{uvd}	undervoltage detection voltage	LDO_MODE = 1	1.65	-	-	V
V_{uvr}	undervoltage recovery voltage	LDO_MODE = 1	-	-	1.745	V
V_{uvhys}	undervoltage hysteresis voltage	LDO_MODE = 1	20	35	-	mV
$I_{DDD(1V8)}$	digital supply current (1.8 V)	TJA1102A; Normal/Sleep Request modes; LDO_MODE = 1 ^[1]	-	95	115	mA
		TJA1102AS; Normal/Sleep Request modes; LDO_MODE = 1 ^[1]	-	48	57	mA
Transmitter analog supply: pins P0_ $V_{DDA(TX)}$ and P1_ $V_{DDA(TX)}$						
$V_{DDA(TX)}$	transmitter analog supply voltage	operating range	3.1	3.3	3.5	V

Table 35. Supply characteristics...continued

$T_{vj} = -40\text{ °C to }+150\text{ °C}$; $V_{DD(I/O)} = 2.9\text{ V to }3.5\text{ V}$; $V_{BAT} = 2.8\text{ V to }40\text{ V}$; $V_{DDA(3V3)} = V_{DDA(TX)} = V_{DDD(3V3)} = 2.9\text{ V to }3.5\text{ V}$; all voltages are defined with respect to ground unless otherwise specified; positive currents flow into the IC.

Symbol	Parameter	Conditions	Min	Typ	Max	Unit
$I_{DDA(TX)}$	transmitter analog supply current	Normal/Sleep Request modes	-	27	33	mA
		Standby/Disable/Reset modes	-	0	50	μA
Input/output supply: pin $V_{DD(I/O)}$						
$V_{DD(I/O)}$	input/output supply voltage	operating range	3.1	3.3	3.5	V
V_{uvd}	undervoltage detection voltage		2.9	-	-	V
V_{uvr}	undervoltage recovery voltage		-	-	3.1	V
V_{uvhys}	undervoltage hysteresis voltage		50	80	-	mV
$I_{DD(I/O)}$	input/output supply current	TJA1102A; Normal/Sleep Request modes; C_{load} on MII pins = 15 pF ^[1]	-	10	15	mA
		TJA1102AS; Normal/Sleep Request modes; C_{load} on MII pins = 15 pF	-	5	7.5	mA
		Standby/Disable modes; no currents in pull-up resistors on digital inputs	-	3	40	μA
		Reset mode; no currents in pull-up resistors on digital inputs ^[1]	-	35	80	μA
Power consumption						
P	power dissipation	TJA1102A; Normal/Sleep Request modes; LDO_MODE = 0	-	700	900	mW
		TJA1102AS; Normal/Sleep Request modes; LDO_MODE = 0	-	360	480	mW
		TJA1102A; Normal/Sleep Request modes; LDO_MODE = 1	-	560	760	mW
		TJA1102AS; Normal/Sleep Request modes; LDO_MODE = 1	-	290	400	mW

[1] Not measured in production; guaranteed by design.

Table 36. xMI interfaces characteristics

$T_{vj} = -40\text{ °C to }+150\text{ °C}$; $V_{DD(I/O)} = 2.9\text{ V to }3.5\text{ V}$; $V_{BAT} = 2.8\text{ V to }40\text{ V}$; $V_{DDA(3V3)} = V_{DDA(TX)} = V_{DDD(3V3)} = 2.9\text{ V to }3.5\text{ V}$; all voltages are defined with respect to ground unless otherwise specified; positive currents flow into the IC.

Symbol	Parameter	Conditions	Min	Typ	Max	Unit
SMI interface: pins MDC and MDIO						
V_{IH}	HIGH-level input voltage		2	-	-	V
V_{IL}	LOW-level input voltage		-	-	0.8	V
C_i	input capacitance	pin MDC ^[1]	-	-	8	pF
		pin MDIO ^[1]	-	-	10	pF

Table 36. xMI interfaces characteristics...continued

$T_{vj} = -40\text{ °C to }+150\text{ °C}$; $V_{DD(I/O)} = 2.9\text{ V to }3.5\text{ V}$; $V_{BAT} = 2.8\text{ V to }40\text{ V}$; $V_{DDA(3V3)} = V_{DDA(TX)} = V_{DDD(3V3)} = 2.9\text{ V to }3.5\text{ V}$; all voltages are defined with respect to ground unless otherwise specified; positive currents flow into the IC.

Symbol	Parameter	Conditions	Min	Typ	Max	Unit
V_{OH}	HIGH-level output voltage	pin MDIO; $I_{OH} = -4\text{ mA}$	$V_{DD(I/O)} - 0.4$	-	-	V
V_{OL}	LOW-level output voltage	pin MDIO; $I_{OL} = 4\text{ mA}$	-	-	0.4	V
I_{IH}	HIGH-level input current	$V_{IH} = V_{DD(I/O)}$	-	-	20	μA
I_{IL}	LOW-level input current	pin MDC; $V_{IL} = 0\text{ V}$	-20	-	-	μA
		pin MDIO; $V_i = 0\text{ V}$	-100	-	-20	μA
R_{pd}	pull-down resistance	on pin MDC	262.5	500	-	k Ω
R_{pu}	pull-up resistance	on pin MDIO	70	100	130	k Ω
(R)MII interface: pins P0_TXER, P0_TXEN, P0_TXDx, P0_TXC, P0_RXDx, P0_RXDV, P0_RXER, P0_RXC, P1_TXER, P1_TXEN, P1_TXDx, P1_TXC, P1_RXDx, P1_RXDV, P1_RXER, P1_RXC ^[2]						
V_{IH}	HIGH-level input voltage		2	-	-	V
V_{IL}	LOW-level input voltage		-	-	0.8	V
C_i	input capacitance		^[1] -	-	8	pF
V_{OH}	HIGH-level output voltage	$I_{OH} = -4\text{ mA}$	$V_{DD(I/O)} - 0.4$	-	-	V
V_{OL}	LOW-level output voltage	$I_{OL} = 4\text{ mA}$	-	-	0.4	V
I_{IH}	HIGH-level input current	$V_{IH} = V_{DD(I/O)}$	-	-	200	μA
I_{IL}	LOW-level input current	$V_{IL} = 0\text{ V}$	-20	-	-	μA
R_{pd}	pull-down resistance	on pins P0_TXER, P0_TXEN, P0_TXDx, P1_TXER, P1_TXEN, P1_TXDx	70	100	130	k Ω
		on pins P0_TXC and P1_TXC; Reverse MII mode	70	100	130	k Ω

[1] Not measured in production; guaranteed by design.

[2] Pins P1_xxx only valid for TJA1102A.

Table 37. General electrical characteristics

$T_{vj} = -40\text{ °C to }+150\text{ °C}$; $V_{DD(I/O)} = 2.9\text{ V to }3.5\text{ V}$; $V_{BAT} = 2.8\text{ V to }40\text{ V}$; $V_{DDA(3V3)} = V_{DDA(TX)} = V_{DDD(3V3)} = 2.9\text{ V to }3.5\text{ V}$; all voltages are defined with respect to ground unless otherwise specified; positive currents flow into the IC.

Symbol	Parameter	Conditions	Min	Typ	Max	Unit
pins RST_N, EN						
V_{IH}	HIGH-level input voltage		2	-	-	V
V_{IL}	LOW-level input voltage		-	-	0.8	V
$V_{hys(i)}$	input hysteresis voltage		0.36	0.5	-	V
C_i	input capacitance		^[1] -	-	8	pF
I_{IH}	HIGH-level input current	at pin RST_N; $V_{IH} = V_{DD(I/O)}$	-	-	20	μA
I_{IL}	LOW-level input current	at pin EN; $V_{IL} = 0\text{ V}$	-20	-	-	μA

Table 37. General electrical characteristics...continued

$T_{vj} = -40\text{ °C to }+150\text{ °C}$; $V_{DD(I/O)} = 2.9\text{ V to }3.5\text{ V}$; $V_{BAT} = 2.8\text{ V to }40\text{ V}$; $V_{DDA(3V3)} = V_{DDA(TX)} = V_{DDD(3V3)} = 2.9\text{ V to }3.5\text{ V}$; all voltages are defined with respect to ground unless otherwise specified; positive currents flow into the IC.

Symbol	Parameter	Conditions	Min	Typ	Max	Unit
R_{pd}	pull-down resistance	on pin EN	70	100	130	k Ω
R_{pu}	pull-up resistance	on pin RST_N	70	100	130	k Ω
pin INT_N						
V_{OL}	LOW-level output voltage	$I_{OL} = 2\text{ mA}$	-	-	0.4	V
pin SEL_1V8						
V_{IH}	HIGH-level input voltage		$0.7 \times V_{DD(I/O)}$	-	-	V
V_{IL}	LOW-level input voltage		-	-	$0.3 \times V_{DD(I/O)}$	V
$V_{hys(i)}$	input hysteresis voltage		$0.1 \times V_{DD(I/O)}$	-	-	V
I_{IL}	LOW-level input current	$V_{IL} = 0\text{ V}$	-5	-	+5	μA
R_{pd}	pull-down resistance	on pin SEL_1V8	70	100	130	k Ω
pin CLK_IN_OUT						
V_{IH}	HIGH-level input voltage		$0.7 \times V_{DD(I/O)}$	-	-	V
V_{IL}	LOW-level input voltage		-	-	$0.3 \times V_{DD(I/O)}$	V
$V_{hys(i)}$	input hysteresis voltage		$0.1 \times V_{DD(I/O)}$	-	-	V
V_{OH}	HIGH-level output voltage	$\text{CLK_MODE} = 01$; $I_{OH} = -4\text{ mA}$	$V_{DD(I/O)} - 0.4$	-	-	V
V_{OL}	LOW-level output voltage	$\text{CLK_MODE} = 01$; $I_{OL} = 4\text{ mA}$	-	-	0.4	V
I_{IL}	LOW-level input current	$\text{CLK_MODE} = 00\text{ or }11$; $V_{IL} = 0\text{ V}$	-5	-	+5	μA
R_{pd}	pull-down resistance	$\text{CLK_MODE} = 00\text{ or }11$	70	100	130	k Ω
pins P0_RXD[3:0], P0_RXER, P0_RXDV, P1_RXD[3:0], P1_RXER, P1_RXDV during pin strapping ^[2]						
V_{IH}	HIGH-level input voltage		2	-	-	V
V_{IL}	LOW-level input voltage		-	-	0.8	V
pin WAKE_IN_OUT						
V_{IH}	HIGH-level input voltage	CONFIG_WAKE = 0 (see Table 29)	2.8	-	4.1	V
		CONFIG_WAKE = 1	$0.44 \times V_{DD(I/O)}$	-	$0.64 \times V_{DD(I/O)}$	V
V_{IL}	LOW-level input voltage	CONFIG_WAKE = 0	2.4	-	3.75	V
		CONFIG_WAKE = 1	$0.38 \times V_{DD(I/O)}$	-	$0.55 \times V_{DD(I/O)}$	V
$V_{hys(i)}$	input hysteresis voltage	CONFIG_WAKE = 0	0.25	-	0.8	V

100BASE-T1 dual/single PHY for automotive Ethernet

Table 37. General electrical characteristics...continued

$T_{vj} = -40\text{ °C to }+150\text{ °C}$; $V_{DD(I/O)} = 2.9\text{ V to }3.5\text{ V}$; $V_{BAT} = 2.8\text{ V to }40\text{ V}$; $V_{DDA(3V3)} = V_{DDA(TX)} = V_{DDD(3V3)} = 2.9\text{ V to }3.5\text{ V}$; all voltages are defined with respect to ground unless otherwise specified; positive currents flow into the IC.

Symbol	Parameter	Conditions	Min	Typ	Max	Unit
		CONFIG_WAKE = 1	$0.025 \times V_{DD(I/O)}$	-	$0.2 \times V_{DD(I/O)}$	V
I_i	input current		-5	-	+5	μA
V_{OH}	HIGH-level output voltage	all modes except Sleep and Power-off; $I_{WAKE_IN_OUT} = 0\text{ mA}$	$V_{BAT} - 0.8$	-	V_{BAT}	V
I_{OL}	LOW-level output current	all modes except Sleep, Power-off; $V_{WAKE_IN_OUT} = 0\text{ V}$	-30	-	-	mA
pin INH						
V_{OH}	HIGH-level output voltage	all modes except Sleep, Power-off; $I_{INH} = -1\text{ mA}$	$V_{BAT} - 1$	-	V_{BAT}	V
I_{OL}	LOW-level output current	all modes except Sleep, Power-off; $V_{INH} = 0\text{ V}$	-15	-7	-2	mA
I_L	leakage current	Sleep, Power-off modes	-5	-	+5	μA
pins XI, XO						
C_i	input capacitance	pin XI ^[1]	-	3.5	-	pF
		pin XO ^[1]	-	2	-	pF
$g_{m(DC)}$	DC transconductance	Normal, Sleep Request modes; MII_MODE = 00, 01 or 11	13.3	25	47	mA/V
Transmitter test results: pins P0_TRX_M, P0_TRX_P, P1_TRX_M, P1_TRX_P ^[3]						
V_{droop}/V_M	droop voltage to peak voltage ratio	100BASE-T1 test mode 1; with respect to initial peak value ^[1]	-45	-	+45	%
$V_{dist(M)}$	peak distortion voltage	100BASE-T1 test mode 4 ^[1]	-	-	15	mV
PSDM	power spectral density mask	100BASE-T1 test mode 5 ^[1]				
		f = 1 MHz	-70.9	-	-63.3	dBm/Hz
		f = 20 MHz	-75.8	-	-64.8	dBm/Hz
		f = 40 MHz	-89.2	-	-68.5	dBm/Hz
		f = 57 MHz to 200 MHz	-	-	-76.5	dBm/Hz
Transmitter output amplitude: pins P0_TRX_M, P0_TRX_P, P1_TRX_M, P1_TRX_P ^{[2][3]}						
$V_{oM(TX)}$	transmitter peak output voltage		-	1	-	V
R_{term}	termination resistance	on each pin; Normal, Sleep Request modes; LINK_CONTROL = 1 ^[4]	47.5	50	52.5	Ω
Temperature protection						
$T_{j(sd)}$	shutdown junction temperature		180	-	200	$^{\circ}\text{C}$

Table 37. General electrical characteristics...continued

$T_{vj} = -40\text{ °C to }+150\text{ °C}$; $V_{DD(I/O)} = 2.9\text{ V to }3.5\text{ V}$; $V_{BAT} = 2.8\text{ V to }4.0\text{ V}$; $V_{DDA(3V3)} = V_{DDA(TX)} = V_{DDD(3V3)} = 2.9\text{ V to }3.5\text{ V}$; all voltages are defined with respect to ground unless otherwise specified; positive currents flow into the IC.

Symbol	Parameter	Conditions	Min	Typ	Max	Unit
$T_{j(sd)rel}$	release shutdown junction temperature		147	-	167	°C
$T_{j(warn)}$	warning junction temperature		155	-	175	°C
$T_{j(warn)rel}$	release warning junction temperature		147	-	167	°C
$T_{j(warn)hys}$	warning junction temperature hysteresis		2	8	-	°C

[1] Not measured in production; guaranteed by design.

[2] Pins P1_xxx only valid for TJA1102A.

[3] Test carried out with external common mode choke and coupling capacitors connected.

[4] Includes the influence of the nominal series resistance of an external common mode choke and 1 kΩ parallel resistors of the common-mode termination circuit.

10 Dynamic characteristics

Table 38. Dynamic characteristics

$T_{vj} = -40\text{ °C to }+150\text{ °C}$; $V_{DD(I/O)} = 2.9\text{ V to }3.5\text{ V}$; $V_{BAT} = 2.8\text{ V to }40\text{ V}$; $V_{DDA(3V3)} = V_{DDA(TX)} = V_{DDD(3V3)} = 2.9\text{ V to }3.5\text{ V}$; all voltages are defined with respect to ground unless otherwise specified; positive currents flow into the IC.

Symbol	Parameter	Conditions	Min	Typ	Max	Unit
MII transmit timing (see Figure 15); MII_DRIVER = 0 (standard output driver strength) ^[1]						
T_{clk}	clock period	pin TXC	-	40	-	ns
δ	duty cycle	pin TXC	35	-	65	%
t_{WH}	pulse width HIGH	pin TXC	14	20	-	ns
t_{WL}	pulse width LOW	pin TXC	14	20	-	ns
t_{su}	set-up time	TXC to TXD[3:0], TXER, TXEN				
		MII	10	-	-	ns
		Reverse MII	10	-	-	ns
t_h	hold time	TXC to TXD[3:0], TXEN, TXER				
		MII	0	-	-	ns
		Reverse MII	10	-	-	ns
MII receive timing (see Figure 16); MII_DRIVER = 0 (standard output driver strength) ^[1]						
T_{clk}	clock period	pin RXC	-	40	-	ns
δ	duty cycle	pin RXC	35	-	65	%
t_{WH}	pulse width HIGH	pin RXC	14	20	-	ns
t_{WL}	pulse width LOW	pin RXC	14	20	-	ns
t_d	delay time	RXC to RXD[3:0], RXDV, RXER				
		MII	15	-	25	ns
		Reverse MII	0	-	25	ns
RMII transmit and receive timing (see Figure 17 and Figure 18); MII_DRIVER = 0 (standard output driver strength) ^[1]						
T_{clk}	clock period	pin REF_CLK	-	20	-	ns
δ	duty cycle	pin REF_CLK	35	-	65	%
t_{WH}	pulse width HIGH	pin REF_CLK	7	10	-	ns
t_{WL}	pulse width LOW	pin REF_CLK	7	10	-	ns
t_{su}	set-up time	REF_CLK to TXD[1:0], TXEN, TXER	4	-	-	ns
t_h	hold time	REF_CLK to TXD[1:0], TXEN, TXER	2	-	-	ns
t_d	delay time	REF_CLK to RXD[1:0], RXER, CRSDV	4	-	13	ns
(R)MII interface timing ^[1]						
t_f	fall time ^[2]	MII: RXD[3:0], RXDV, RXER				
		MII_DRIVER = 0; $C_L = 15\text{ pF}$	1.3	-	5	ns
		MII_DRIVER = 1; $C_L = 7.5\text{ pF}$	2	-	7.7	ns
		MII: TXC, RXC; $C_L = 15\text{ pF}$	1.3	-	5	ns
		RMII: RXD[1:0], CRSDV, RXER				

Table 38. Dynamic characteristics...continued

$T_{vj} = -40\text{ °C to }+150\text{ °C}$; $V_{DD(I/O)} = 2.9\text{ V to }3.5\text{ V}$; $V_{BAT} = 2.8\text{ V to }40\text{ V}$; $V_{DDA(3V3)} = V_{DDA(TX)} = V_{DDD(3V3)} = 2.9\text{ V to }3.5\text{ V}$; all voltages are defined with respect to ground unless otherwise specified; positive currents flow into the IC.

Symbol	Parameter	Conditions	Min	Typ	Max	Unit
		MII_DRIVER = 0; $C_L = 15\text{ pF}$	0.7	-	2.5	ns
		MII_DRIVER = 1; $C_L = 7.5\text{ pF}$	0.9	-	3.4	ns
		RMII: REF_CLK; $C_L = 15\text{ pF}$	0.7	-	2.5	ns
t_r	rise time ^[3]	MII: RXD[3:0], RXDV, RXER				
		MII_DRIVER = 0; $C_L = 15\text{ pF}$	1.3	-	5	ns
		MII_DRIVER = 1; $C_L = 7.5\text{ pF}$	2	-	7.7	ns
		MII: TXC, RXC; $C_L = 15\text{ pF}$	1.3	-	5	ns
		RMII: RXD[1:0], CRSDV, RXER				
		MII_DRIVER = 0; $C_L = 15\text{ pF}$	0.7	-	2.5	ns
		MII_DRIVER = 1; $C_L = 7.5\text{ pF}$	0.9	-	3.4	ns
		RMII: REF_CLK; $C_L = 15\text{ pF}$	0.7	-	2.5	ns
SMI timing (see Figure 19) ^[1]						
$T_{clk(MDC)}$	MDC clock period		400	-	-	ns
$t_{WH(MDC)}$	MDC pulse width HIGH		160	-	-	ns
$t_{WL(MDC)}$	MDC pulse width LOW		160	-	-	ns
$t_{su(MDIO)}$	MDIO set-up time	to rising edge on MDC	10	-	-	ns
$t_h(MDIO)$	MDIO hold time	from rising edge on MDC	10	-	-	ns
$t_d(MDC-MDIO)$	delay time from MDC to MDIO	from rising edge on MDC; read from PHY	0	-	300	ns
WAKE timing; pin WAKE_IN_OUT ^[1]						
$t_{det(wake)}$	wake-up detection time	LOC_WU_TIM = 00	10	-	20	ms
		LOC_WU_TIM = 01	250	-	500	μs
		LOC_WU_TIM = 10	100	-	200	μs
		LOC_WU_TIM = 11	20	-	40	μs
t_p	pulse duration	LOC_WU_TIM = 00	20	-	40	ms
		LOC_WU_TIM = 01	500	-	1000	μs
		LOC_WU_TIM = 10	200	-	400	μs
		LOC_WU_TIM = 11	40	-	80	μs
t_{on}	turn-on time	$R_L = 100\text{ k}\Omega$; $C_L = 50\text{ pF}$; $V_{WAKE_IN_OUT} = 2\text{ V}$	0	2	50	μs
t_{off}	turn-off time	$R_L = 100\text{ k}\Omega$; $C_L = 50\text{ pF}$; $V_{WAKE_IN_OUT} = 2\text{ V}$	5	50	65	μs
INH timing ^[1] ; pin INH						
t_{on}	turn-on time	$R_L = 100\text{ k}\Omega$; $C_L = 50\text{ pF}$; $V_{th(INH)} = 2\text{ V}$	0	2	50	μs
t_{off}	turn-off time	$R_L = 100\text{ k}\Omega$; $C_L = 50\text{ pF}$; $V_{th(INH)} = 2\text{ V}$	5	50	65	μs

Table 38. Dynamic characteristics...continued

T_{vj} = -40 °C to +150 °C; $V_{DD(I/O)}$ = 2.9 V to 3.5 V; V_{BAT} = 2.8 V to 40 V; $V_{DDA(3V3)} = V_{DDA(TX)} = V_{DDD(3V3)} = 2.9 V$ to 3.5 V; all voltages are defined with respect to ground unless otherwise specified; positive currents flow into the IC.

Symbol	Parameter	Conditions	Min	Typ	Max	Unit
interrupt timing ^[1] ; pin INT_N						
t_{on}	turn-on time	$R_{pu} = 10\text{ k}\Omega$; $C_L = 15\text{ pF}$	8	-	20	μs
t_{off}	turn-off time	$R_{pu} = 10\text{ k}\Omega$; $C_L = 15\text{ pF}$	8	-	20	μs
PCS-RX timeout timing						
$t_{to(PCS-RX)}$ ^[4]	PCS-RX time-out time	Normal and Sleep Request modes				
		JUMBO_ENABLE = 0	-	1.1	-	ms
		JUMBO_ENABLE = 1	-	2.2	-	ms
Cable test timing						
$t_{to(cbl_tst)}$	cable test time-out time	Normal mode; CABLE_TEST = 1	-	100	-	μs
pins RST_N, EN ^[1]						
$t_{det(rst)}$	reset detection time	on pin RSTN; $V_{uvd(VDDIO)} < V_{DD(I/O)} \leq 3.5\text{ V}$	5	-	20	μs
$t_{det(EN)}$	detection time on pin EN	$V_{uvd(VDDIO)} < V_{DD(I/O)} \leq 3.5\text{ V}$	5	-	20	μs
Transmitter test results						
$t_{jit(RMS)}$	RMS jitter time	Master mode	-	-	50	ps
		Slave mode (with link); SLAVE_JITTER_TEST = 1	- ^[1] - ^[5]	-	150	ps
Undervoltage detection ^[1]						
$t_{det(uv)}$	undervoltage detection time	on pin V_{BAT} ; $V_{BAT} = 2.7\text{ V}$	0	-	30	μs
		on pin $V_{DDA(3V3)}$; $V_{DDA(3V3)} = 2.8\text{ V}$	2	-	30	μs
		on pin $V_{DDD(3V3)}$; $V_{DDD(3V3)} = 2.8\text{ V}$	2	-	30	μs
		on pin $V_{DDD(1V8)}$	2	-	30	μs
		$V_{DD(I/O)} = 2.8\text{ V}$	2	-	30	μs
$t_{rec(uv)}$	undervoltage recovery time	on pin $V_{DDA(3V3)}$; $V_{DDA(3V3)} = 3.2\text{ V}$	2	-	30	μs
		on pin $V_{DDD(3V3)}$; $V_{DDD(3V3)} = 3.2\text{ V}$	2	-	30	μs
		on pin $V_{DDD(1V8)}$	2	-	30	μs
		on pin $V_{DD(I/O)}$; $V_{DD(I/O)} = 3.2\text{ V}$	2	-	30	μs
$t_{to(uvd)}$	undervoltage detection time-out time	for transition from Standby to Sleep mode (see Section 6.9.1)	300	-	670	ms
General timing parameters ^[1]						
$t_{s(pon)}$	power-on settling time	from power-on to Standby mode	-	-	2	ms
$t_{init(PHY)}$	PHY initialization time	from Standby mode to Normal mode	-	-	2	ms
$t_{to(req)sleep}$	sleep request time-out time	SLEEP_REQUEST_TO = 00	360	-	500	μs
		SLEEP_REQUEST_TO = 01	900	-	1150	μs
		SLEEP_REQUEST_TO = 10	3.6	-	4.4	ms

Table 38. Dynamic characteristics...continued

$T_{vj} = -40\text{ }^{\circ}\text{C}$ to $+150\text{ }^{\circ}\text{C}$; $V_{DD(I/O)} = 2.9\text{ V}$ to 3.5 V ; $V_{BAT} = 2.8\text{ V}$ to 40 V ; $V_{DDA(3V3)} = V_{DDA(TX)} = V_{DDD(3V3)} = 2.9\text{ V}$ to 3.5 V ; all voltages are defined with respect to ground unless otherwise specified; positive currents flow into the IC.

Symbol	Parameter	Conditions	Min	Typ	Max	Unit
$t_{to(ack)sleep}$	sleep acknowledge time-out time	SLEEP_REQUEST_TO = 11	14.4	-	17.6	ms
		SLEEP_REQUEST_TO = 00	180	-	250	μs
		SLEEP_REQUEST_TO = 01	450	-	575	μs
		SLEEP_REQUEST_TO = 10	1.8	-	2.2	ms
		SLEEP_REQUEST_TO = 11	7.2	-	8.8	ms
$t_{det(PHY)}$	PHY detection time	on bus pins P0_TRX_P, P0_TRX_M, P1_TRX_P and P1_TRX_M ^[6]	-	-	0.7	ms
$t_{to(pd)autn}$	autonomous power-down time-out time	Normal mode; AUTO_PWD = 1	1	-	2	s
t_{PD}	propagation delay	from MII to MDI; Normal mode	140	-	300	ns
		from MDI to MII; Normal mode	760	-	920	ns
		from RMII to MDI; Normal mode	190	-	540	ns
		from MDI to RMII; Normal mode	700	-	1070	ns
$t_{w(wake)}$	wake-up pulse width	Normal mode; no active link; wake-up forwarding	0.7	1.0	1.3	ms

- [1] Not measured in production; guaranteed by design.
- [2] From 2 V to 0.8 V.
- [3] From 0.8 V to 2 V.
- [4] rcv_max_timer in the IEEE specification [1].
- [5] Measured at the P0_RXER pin, representing the transmit clock (TX_CLK) of P1, or measured at the P1_RXER pin, representing the transmit clock of P0.
- [6] Pins P1_xxx only valid for TJA1102A.

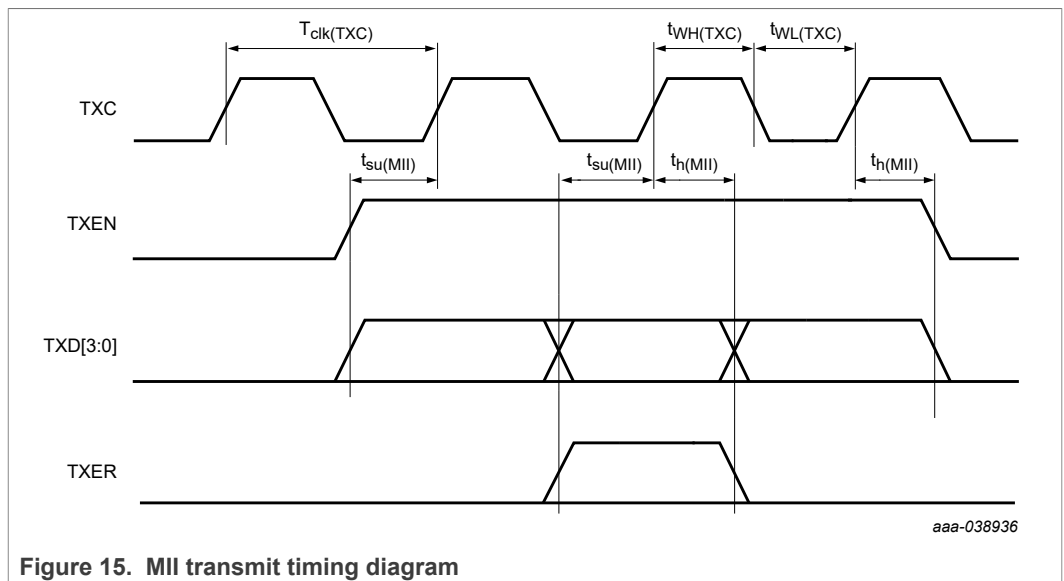

Figure 15. MII transmit timing diagram

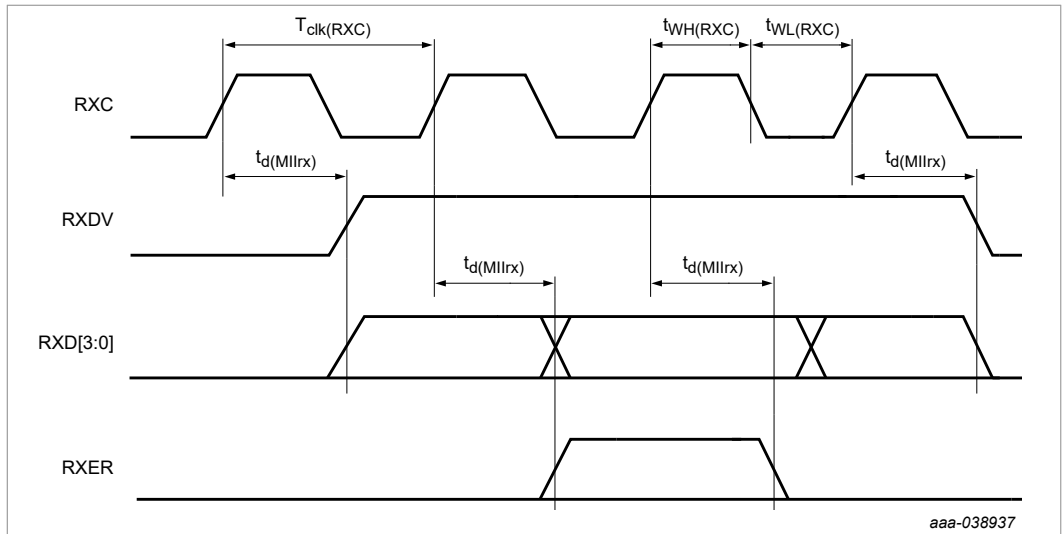

Figure 16. MII receive timing diagram

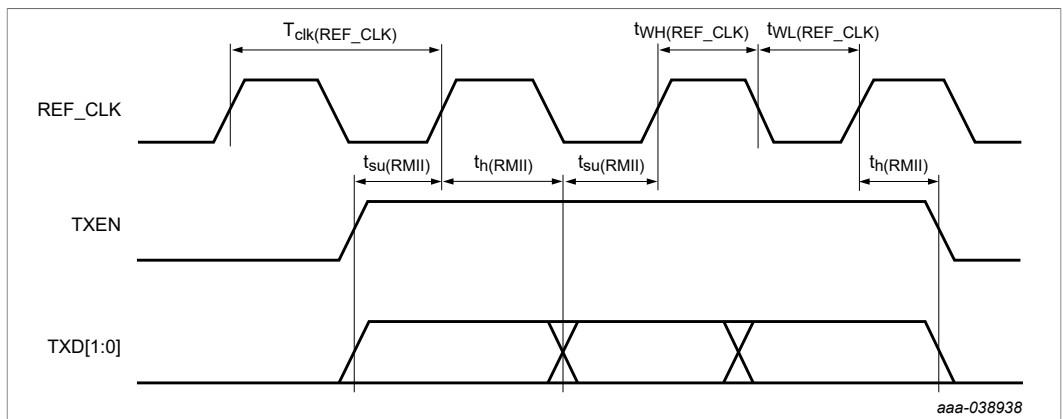

Figure 17. RMI transmit timing diagram

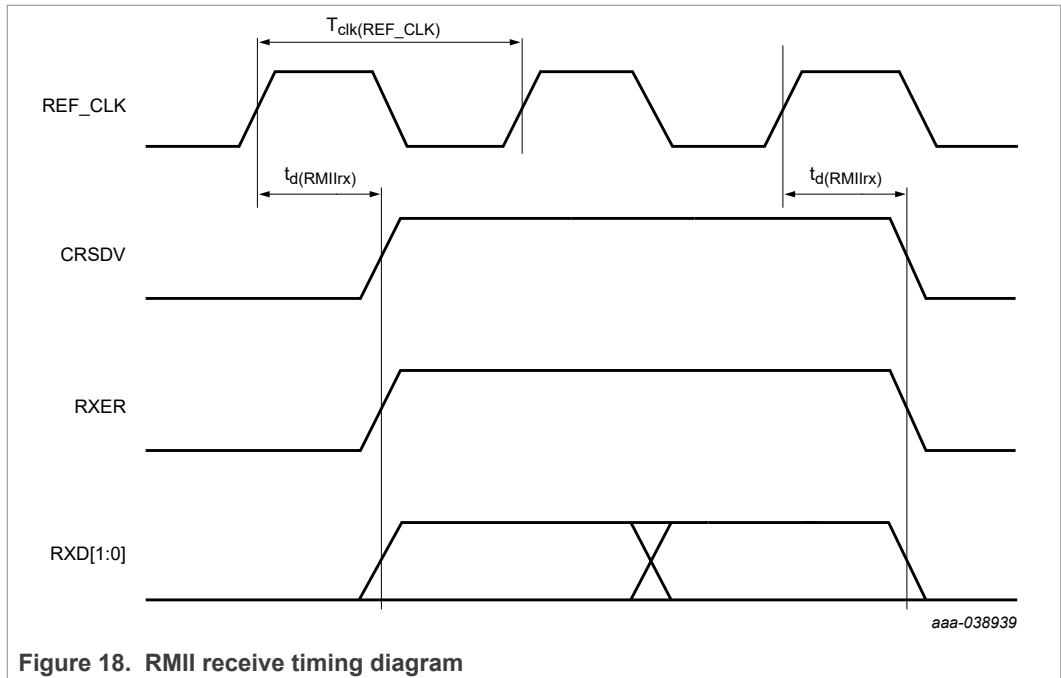

Figure 18. RMI receive timing diagram

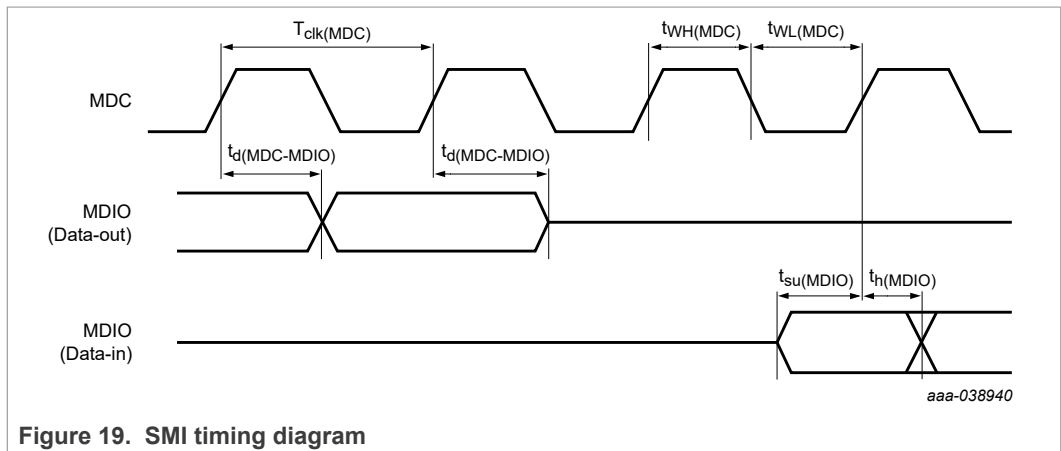

Figure 19. SMI timing diagram

11 Application information

The MDI circuit used for each PHY port is shown in [Figure 20](#). The common mode termination depends on OEM requirements and might vary, depending on the application.

The common mode choke is expected to be compliant with the OPEN Alliance CMC specification. The 100 nF coupling capacitors should have a voltage range ≥ 50 V with 10 % (max) tolerance.

The TJA1102A provides an ESD robustness of ± 6 kV according to IEC61000-4-2 and HBM at the IC pins. With CMC and coupling capacitors, it is able to withstand $\geq \pm 8$ kV for IEC 61000-4-2 on the connector pins.

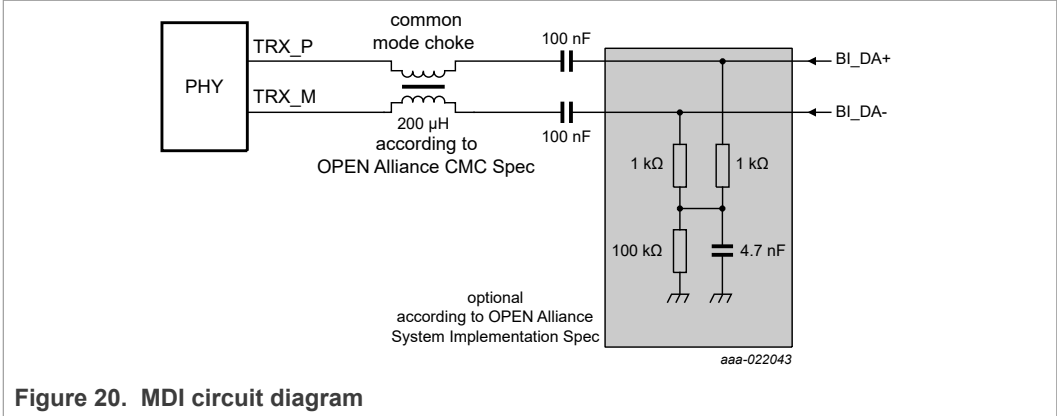

Further information can be found in the TJA1102A application hints [2].

12 Package information

The TJA1102A comes in the HVQFN-56 package as shown in Figure 21. Measuring just 64 mm² with a pitch of 0.5 mm, it is particularly suited to PCB space-constrained applications, such as an integrated IP camera module. The package features wettable sides/flanks to allow for optical inspection of the soldering process. The exposed die pad shown in the package diagram must be connected to ground.

13 Package outline

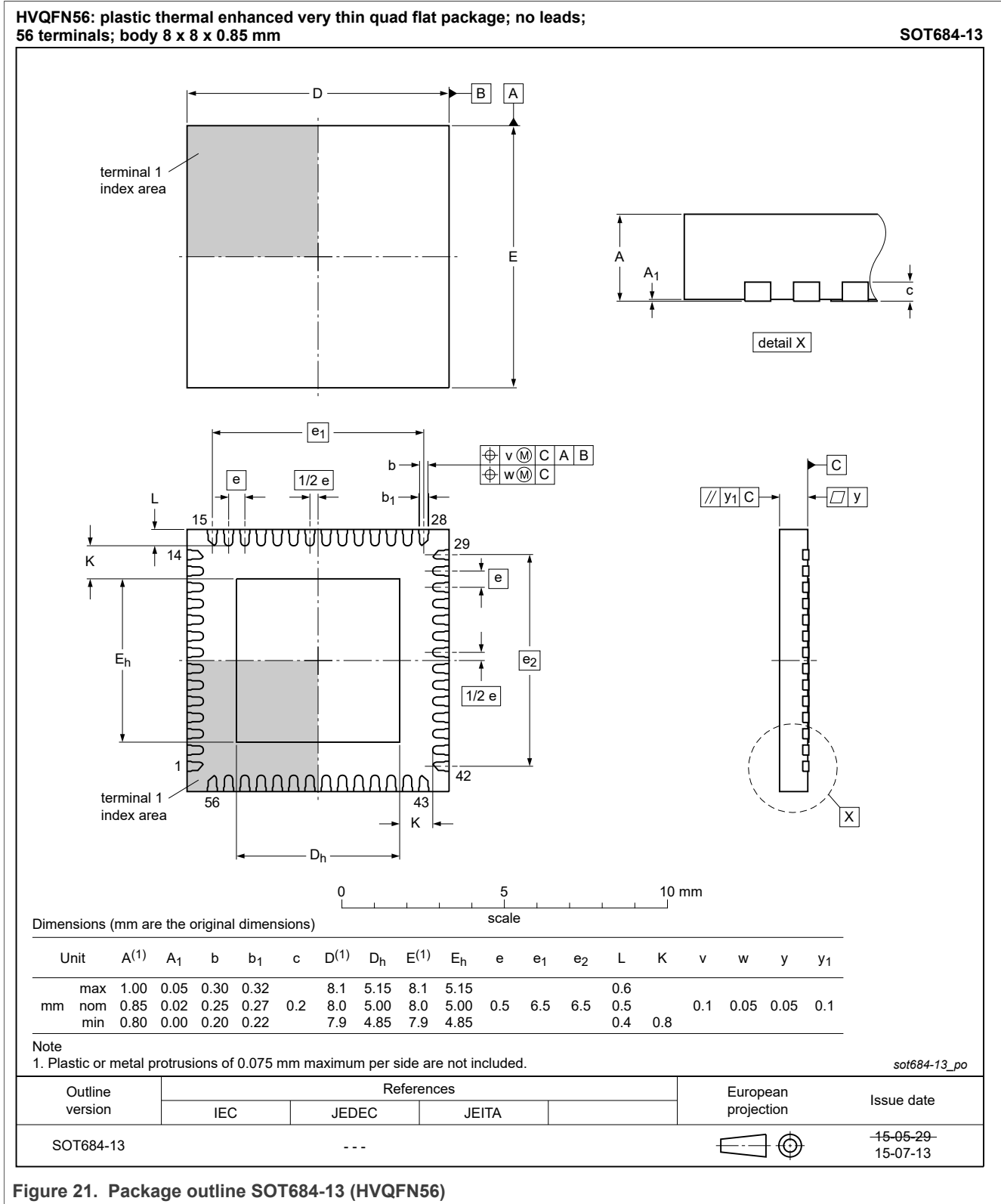

Figure 21. Package outline SOT684-13 (HVQFN56)

14 Soldering of SMD packages

This text provides a very brief insight into a complex technology. A more in-depth account of soldering ICs can be found in Application Note AN10365 “Surface mount reflow soldering description”.

14.1 Introduction to soldering

Soldering is one of the most common methods through which packages are attached to Printed Circuit Boards (PCBs), to form electrical circuits. The soldered joint provides both the mechanical and the electrical connection. There is no single soldering method that is ideal for all IC packages. Wave soldering is often preferred when through-hole and Surface Mount Devices (SMDs) are mixed on one printed wiring board; however, it is not suitable for fine pitch SMDs. Reflow soldering is ideal for the small pitches and high densities that come with increased miniaturization.

14.2 Wave and reflow soldering

Wave soldering is a joining technology in which the joints are made by solder coming from a standing wave of liquid solder. The wave soldering process is suitable for the following:

- Through-hole components
- Leaded or leadless SMDs, which are glued to the surface of the printed circuit board

Not all SMDs can be wave soldered. Packages with solder balls, and some leadless packages which have solder lands underneath the body, cannot be wave soldered. Also, leaded SMDs with leads having a pitch smaller than ~0.6 mm cannot be wave soldered, due to an increased probability of bridging.

The reflow soldering process involves applying solder paste to a board, followed by component placement and exposure to a temperature profile. Leaded packages, packages with solder balls, and leadless packages are all reflow solderable.

Key characteristics in both wave and reflow soldering are:

- Board specifications, including the board finish, solder masks and vias
- Package footprints, including solder thieves and orientation
- The moisture sensitivity level of the packages
- Package placement
- Inspection and repair
- Lead-free soldering versus SnPb soldering

14.3 Wave soldering

Key characteristics in wave soldering are:

- Process issues, such as application of adhesive and flux, clinching of leads, board transport, the solder wave parameters, and the time during which components are exposed to the wave
- Solder bath specifications, including temperature and impurities

14.4 Reflow soldering

Key characteristics in reflow soldering are:

- Lead-free versus SnPb soldering; note that a lead-free reflow process usually leads to higher minimum peak temperatures (see [Figure 22](#)) than a SnPb process, thus reducing the process window
- Solder paste printing issues including smearing, release, and adjusting the process window for a mix of large and small components on one board
- Reflow temperature profile; this profile includes preheat, reflow (in which the board is heated to the peak temperature) and cooling down. It is imperative that the peak temperature is high enough for the solder to make reliable solder joints (a solder paste characteristic). In addition, the peak temperature must be low enough that the packages and/or boards are not damaged. The peak temperature of the package depends on package thickness and volume and is classified in accordance with [Table 39](#) and [Table 40](#)

Table 39. SnPb eutectic process (from J-STD-020D)

Package thickness (mm)	Package reflow temperature (°C)	
	Volume (mm ³)	
	< 350	≥ 350
< 2.5	235	220
≥ 2.5	220	220

Table 40. Lead-free process (from J-STD-020D)

Package thickness (mm)	Package reflow temperature (°C)		
	Volume (mm ³)		
	< 350	350 to 2000	> 2000
< 1.6	260	260	260
1.6 to 2.5	260	250	245
> 2.5	250	245	245

Moisture sensitivity precautions, as indicated on the packing, must be respected at all times.

Studies have shown that small packages reach higher temperatures during reflow soldering, see [Figure 22](#).

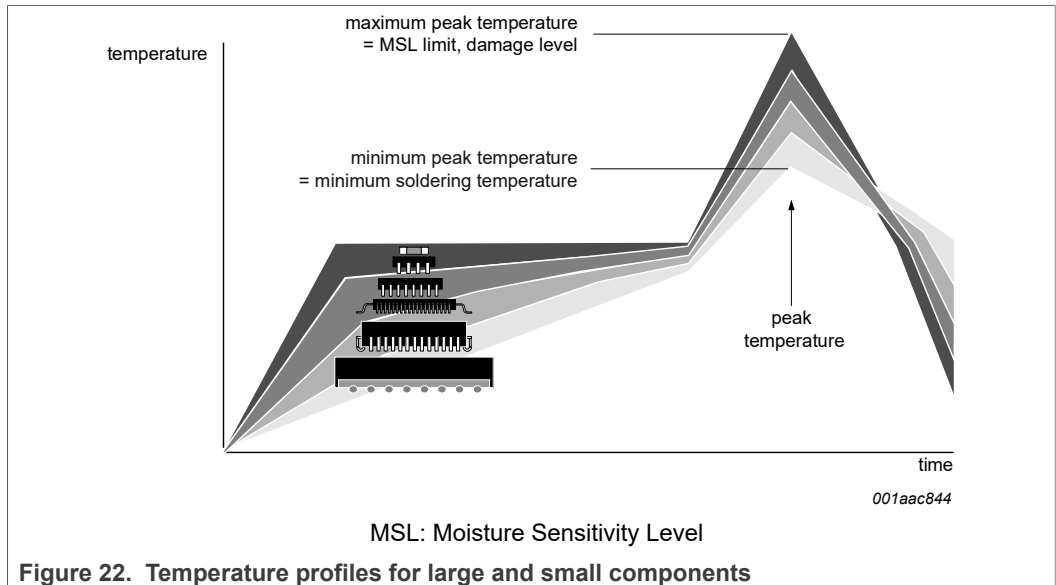

Figure 22. Temperature profiles for large and small components

For further information on temperature profiles, refer to Application Note AN10365 “Surface mount reflow soldering description”.

15 References

- [1] **IEEE 802.3bw-2015** — IEEE Standard for Ethernet Amendment 1: Physical Layer Specifications and Management Parameters for 100 Mb/s Operation over a Single Balanced Twisted Pair Cable (100BASE-T1)
- [2] **AN13171** — Application note for TJA1102A 100BASE-T1 dual/single PHY for automotive Ethernet, NXP Semiconductors

16 Revision history

Table 41. Revision history

Document ID	Release date	Data sheet status	Change notice	Supersedes
TJA1102A v.1	20210607	Product data sheet	-	-

17 Legal information

17.1 Data sheet status

Document status ^{[1][2]}	Product status ^[3]	Definition
Objective [short] data sheet	Development	This document contains data from the objective specification for product development.
Preliminary [short] data sheet	Qualification	This document contains data from the preliminary specification.
Product [short] data sheet	Production	This document contains the product specification.

[1] Please consult the most recently issued document before initiating or completing a design.

[2] The term 'short data sheet' is explained in section "Definitions".

[3] The product status of device(s) described in this document may have changed since this document was published and may differ in case of multiple devices. The latest product status information is available on the Internet at URL <http://www.nxp.com>.

17.2 Definitions

Draft — A draft status on a document indicates that the content is still under internal review and subject to formal approval, which may result in modifications or additions. NXP Semiconductors does not give any representations or warranties as to the accuracy or completeness of information included in a draft version of a document and shall have no liability for the consequences of use of such information.

Short data sheet — A short data sheet is an extract from a full data sheet with the same product type number(s) and title. A short data sheet is intended for quick reference only and should not be relied upon to contain detailed and full information. For detailed and full information see the relevant full data sheet, which is available on request via the local NXP Semiconductors sales office. In case of any inconsistency or conflict with the short data sheet, the full data sheet shall prevail.

Product specification — The information and data provided in a Product data sheet shall define the specification of the product as agreed between NXP Semiconductors and its customer, unless NXP Semiconductors and customer have explicitly agreed otherwise in writing. In no event however, shall an agreement be valid in which the NXP Semiconductors product is deemed to offer functions and qualities beyond those described in the Product data sheet.

17.3 Disclaimers

Limited warranty and liability — Information in this document is believed to be accurate and reliable. However, NXP Semiconductors does not give any representations or warranties, expressed or implied, as to the accuracy or completeness of such information and shall have no liability for the consequences of use of such information. NXP Semiconductors takes no responsibility for the content in this document if provided by an information source outside of NXP Semiconductors. In no event shall NXP Semiconductors be liable for any indirect, incidental, punitive, special or consequential damages (including - without limitation - lost profits, lost savings, business interruption, costs related to the removal or replacement of any products or rework charges) whether or not such damages are based on tort (including negligence), warranty, breach of contract or any other legal theory. Notwithstanding any damages that customer might incur for any reason whatsoever, NXP Semiconductors' aggregate and cumulative liability towards customer for the products described herein shall be limited in accordance with the Terms and conditions of commercial sale of NXP Semiconductors.

Right to make changes — NXP Semiconductors reserves the right to make changes to information published in this document, including without limitation specifications and product descriptions, at any time and without

notice. This document supersedes and replaces all information supplied prior to the publication hereof.

Applications — Applications that are described herein for any of these products are for illustrative purposes only. NXP Semiconductors makes no representation or warranty that such applications will be suitable for the specified use without further testing or modification. Customers are responsible for the design and operation of their applications and products using NXP Semiconductors products, and NXP Semiconductors accepts no liability for any assistance with applications or customer product design. It is customer's sole responsibility to determine whether the NXP Semiconductors product is suitable and fit for the customer's applications and products planned, as well as for the planned application and use of customer's third party customer(s). Customers should provide appropriate design and operating safeguards to minimize the risks associated with their applications and products. NXP Semiconductors does not accept any liability related to any default, damage, costs or problem which is based on any weakness or default in the customer's applications or products, or the application or use by customer's third party customer(s). Customer is responsible for doing all necessary testing for the customer's applications and products using NXP Semiconductors products in order to avoid a default of the applications and the products or of the application or use by customer's third party customer(s). NXP does not accept any liability in this respect.

Limiting values — Stress above one or more limiting values (as defined in the Absolute Maximum Ratings System of IEC 60134) will cause permanent damage to the device. Limiting values are stress ratings only and (proper) operation of the device at these or any other conditions above those given in the Recommended operating conditions section (if present) or the Characteristics sections of this document is not warranted. Constant or repeated exposure to limiting values will permanently and irreversibly affect the quality and reliability of the device.

Terms and conditions of commercial sale — NXP Semiconductors products are sold subject to the general terms and conditions of commercial sale, as published at <http://www.nxp.com/profile/terms>, unless otherwise agreed in a valid written individual agreement. In case an individual agreement is concluded only the terms and conditions of the respective agreement shall apply. NXP Semiconductors hereby expressly objects to applying the customer's general terms and conditions with regard to the purchase of NXP Semiconductors products by customer.

No offer to sell or license — Nothing in this document may be interpreted or construed as an offer to sell products that is open for acceptance or the grant, conveyance or implication of any license under any copyrights, patents or other industrial or intellectual property rights.

Suitability for use in automotive applications — This NXP product has been qualified for use in automotive applications. If this product is used by customer in the development of, or for incorporation into, products or services (a) used in safety critical applications or (b) in which failure could lead to death, personal injury, or severe physical or environmental damage (such products and services hereinafter referred to as "Critical Applications"),

then customer makes the ultimate design decisions regarding its products and is solely responsible for compliance with all legal, regulatory, safety, and security related requirements concerning its products, regardless of any information or support that may be provided by NXP. As such, customer assumes all risk related to use of any products in Critical Applications and NXP and its suppliers shall not be liable for any such use by customer. Accordingly, customer will indemnify and hold NXP harmless from any claims, liabilities, damages and associated costs and expenses (including attorneys' fees) that NXP may incur related to customer's incorporation of any product in a Critical Application.

Export control — This document as well as the item(s) described herein may be subject to export control regulations. Export might require a prior authorization from competent authorities.

Translations — A non-English (translated) version of a document is for reference only. The English version shall prevail in case of any discrepancy between the translated and English versions.

Security — Customer understands that all NXP products may be subject to unidentified or documented vulnerabilities. Customer is responsible for the design and operation of its applications and products throughout

their lifecycles to reduce the effect of these vulnerabilities on customer's applications and products. Customer's responsibility also extends to other open and/or proprietary technologies supported by NXP products for use in customer's applications. NXP accepts no liability for any vulnerability. Customer should regularly check security updates from NXP and follow up appropriately. Customer shall select products with security features that best meet rules, regulations, and standards of the intended application and make the ultimate design decisions regarding its products and is solely responsible for compliance with all legal, regulatory, and security related requirements concerning its products, regardless of any information or support that may be provided by NXP. NXP has a Product Security Incident Response Team (PSIRT) (reachable at PSIRT@nxp.com) that manages the investigation, reporting, and solution release to security vulnerabilities of NXP products.

17.4 Trademarks

Notice: All referenced brands, product names, service names and trademarks are the property of their respective owners.

NXP — wordmark and logo are trademarks of NXP B.V.

Contents

1	General description	1	6.9.6	Polarity detection	27
2	Features and benefits	1	6.9.7	Interleave detection	27
2.1	General	1	6.9.8	Loopback modes	27
2.2	Optimized for automotive use cases	1	6.9.8.1	Internal loopback	27
2.3	Low-power mode	2	6.9.8.2	External loopback	28
2.4	Diagnosis	2	6.9.8.3	Remote loopback	28
2.5	Miscellaneous	2	6.10	Hardware configuration	28
3	Ordering information	2	6.11	SMI registers	30
4	Block diagram	2	6.11.1	Register mapping overview	30
5	Pinning information	4	6.11.2	TJA1102A registers	31
5.1	TJA1102A pinning	4	7	Limiting values	46
5.2	TJA1102AS pinning	8	8	Thermal characteristics	47
6	Functional description	11	9	Static characteristics	47
6.1	System configuration	11	10	Dynamic characteristics	54
6.1.1	Clocking scheme with MII and clock provided by the switch and one of the TJA1102A devices	12	11	Application information	59
6.1.2	Clocking scheme with RMII and clock provided by the switch	13	12	Package information	60
6.2	MII and RMII	13	13	Package outline	61
6.2.1	MII	14	14	Soldering of SMD packages	62
6.2.2	RMII	15	14.1	Introduction to soldering	
6.2.2.1	Signaling and encoding	15	14.2	Wave and reflow soldering	
6.2.3	Reverse MII	16	14.3	Wave soldering	
6.3	System controller	17	14.4	Reflow soldering	
6.3.1	Operating modes	17	15	References	64
6.3.1.1	Power-off mode	17	16	Revision history	64
6.3.1.2	Standby mode	17	17	Legal information	65
6.3.1.3	Normal mode	18			
6.3.1.4	Disable mode	18			
6.3.1.5	Sleep mode	18			
6.3.1.6	Sleep Request mode	19			
6.3.1.7	Silent mode	19			
6.3.1.8	Reset mode	20			
6.3.2	Status of functional blocks in TJA1102A operating modes	20			
6.4	Mode transitions	21			
6.5	Sleep and wake-up forwarding concept	23			
6.6	Autonomous operation	24			
6.7	Autonomous power-down	24			
6.8	Test modes	24			
6.8.1	Test mode 1	24			
6.8.2	Test mode 2	24			
6.8.3	Test mode 3	24			
6.8.4	Test mode 4	24			
6.8.5	Test mode 5	25			
6.8.6	Slave jitter test	25			
6.9	Error diagnosis	25			
6.9.1	Undervoltage detection	25			
6.9.2	Cabling errors	26			
6.9.3	Link stability	26			
6.9.4	Link-fail counter	26			
6.9.5	Jabber detection	27			

Please be aware that important notices concerning this document and the product(s) described herein, have been included in section 'Legal information'.