

Single Line Ring Generator Controller

PRELIMINARY

FEATURES

- Novel Topology for Low-Cost, Efficient Generation of Ring Voltage
- Provides DC Offset and “Talk Battery” Voltage for Off-Hook Conditions
- Selectable 20,25 and 50 Hz Ring Frequency
- Secondary (AC) Current Limiting Allows Removal of AC Voltage under Off-Hook Conditions
- Primary Current Limiting to turn Power Stage off under Fault Conditions
- Operates from a Single 12V Supply

DESCRIPTION

The UCC3751 controller is designed for driving a power stage that generates low frequency, high voltage sinusoidal signals for telephone ringing applications. The controller and the power stage are most suitable for single line applications where low cost, high efficiency and minimum parts count are critical. In addition to providing the sinusoidal ringing signal, the controller and the power stage are designed to provide the required DC voltage across the output when the phone goes off-hook. The DC voltage is also added as the offset to the ringing signal. This feature eliminates the need to have a separate talk battery voltage power supply as well as relays and drivers to switch between the ringing voltage and the talk battery.

The UCC3751 directly drives primary side switches used to implement a push-pull resonant converter topology and transformer coupled sampling switches located on the secondary of the converter. For normal ring signal generation, the primary switching frequency and secondary sampling frequency are precisely offset from each other by the ringing frequency to produce a high voltage low frequency alias signal at the output. The off-hook condition is detected by sensing the AC current and when AC limit is exceeded, the sampling frequency is set to be equal to the primary switching frequency to produce a DC output.

The drive signal frequencies are derived from a high frequency (3579545 Hz) crystal. The primary switching frequency is 89.488 kHz and the sampling frequency is 20, 25 or 50 Hz less depending on the status of frequency select pins FS0 and FS1.

The circuits described in this datasheet are covered under US Patent #5,663,878 and other patents pending.

TYPICAL APPLICATIONS CIRCUIT

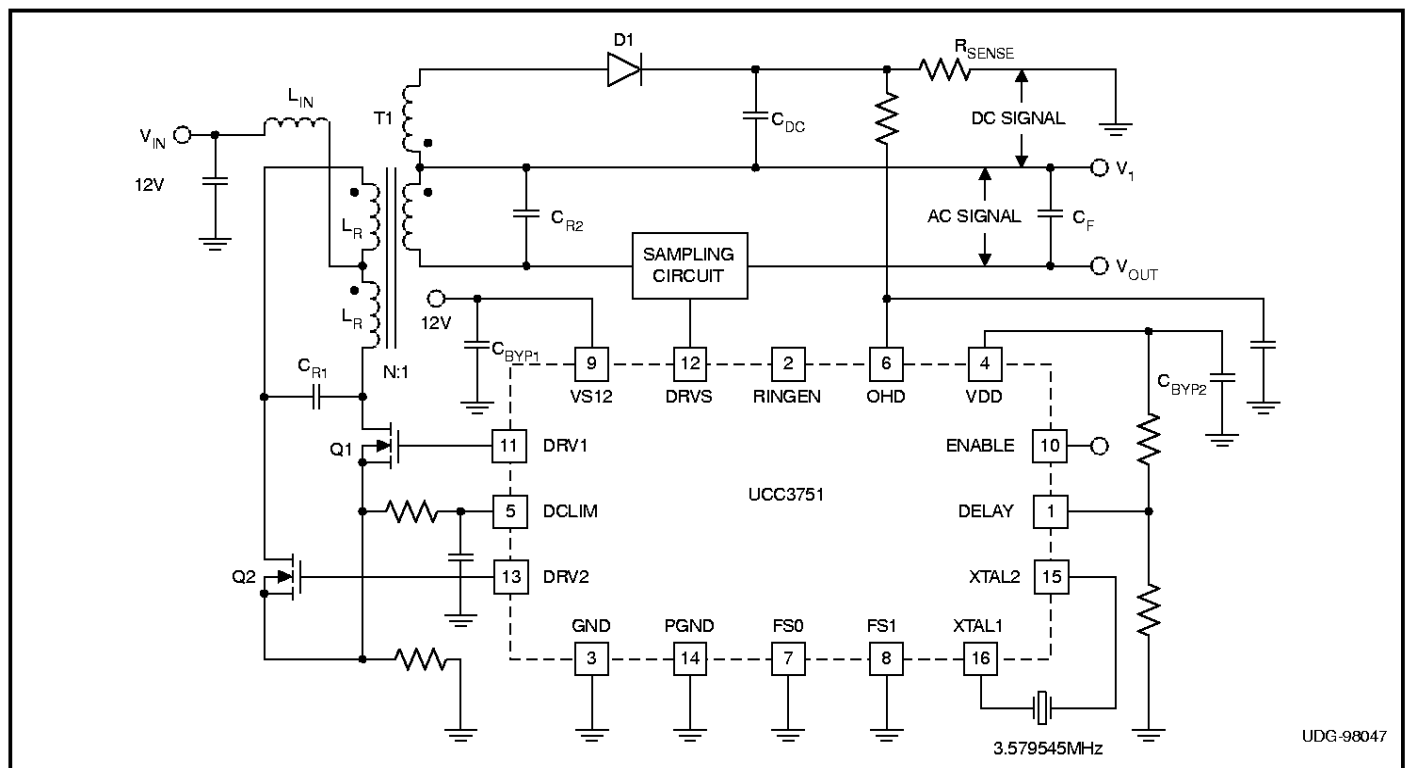

ABSOLUTE MAXIMUM RATINGS

Input Supply Voltage	14V
Analog Inputs (OHD, DCLIM, XTAL1, XTAL2)	
Maximum Forced Voltage	-0.3 to 5V
Logic Inputs	
Maximum Forced Voltage	-0.3 to 7.5V
Reference Output Current (V _{DD})	Internally Limited
Output Current (DRV1, DRV2, DRVS) Pulsed	1.5A
Operating Junction Temperature	-55°C to +125°C
Storage Temperature	-65°C to +150°C

Note: Unless otherwise indicated, voltages are referenced to ground and currents are positive into, negative out of, the specific terminals. Pulsed is defined as a less than 10% duty cycle with a maximum duration of 500µs.

CONNECTION DIAGRAM

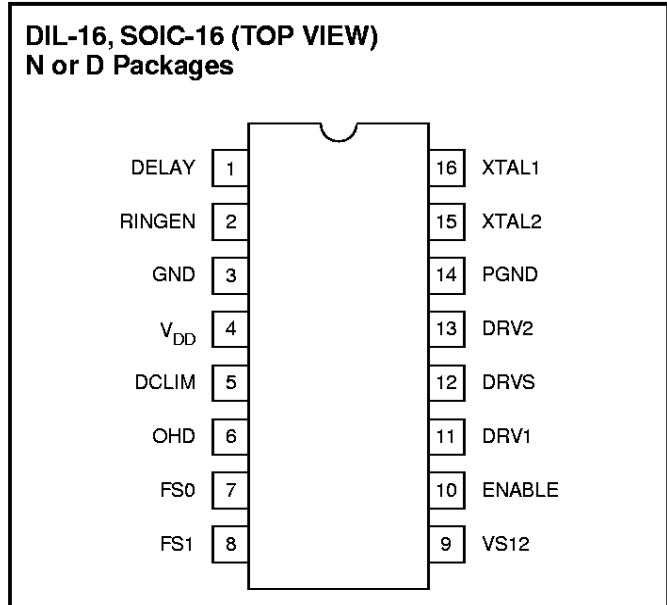

BLOCK DIAGRAM

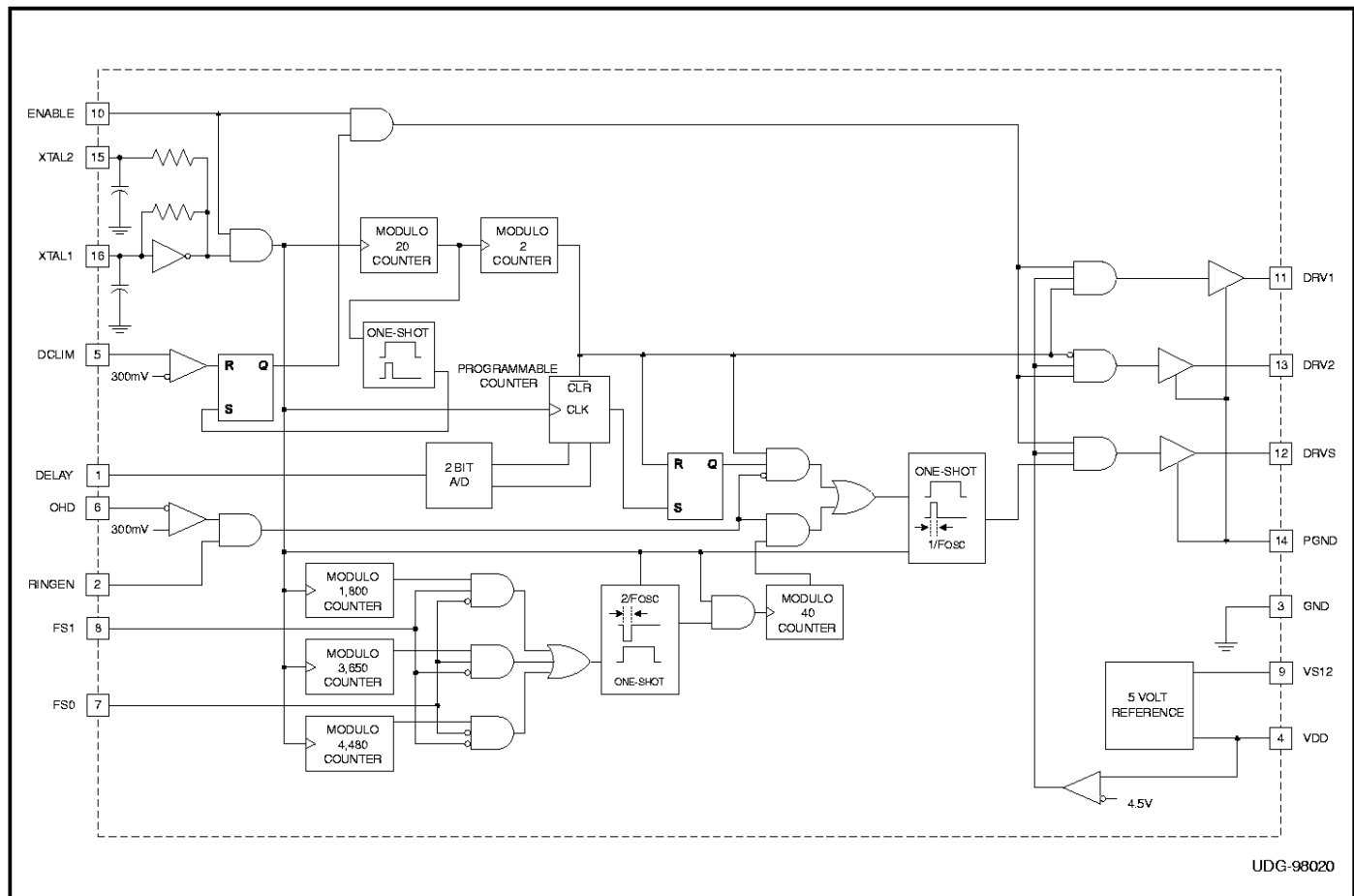

Table I. Frequency selectability decoding.

FS1	FS0	MODE	Sine Wave Frequency (Hz)
0	0	1	20
0	1	1	25
1	0	1	50
1	1	3	0
OHD = 0.5		2	0

RINGEN	OHD	FS1	FS0	F _{DRVS}	F _{DRV} -F _{DRVS}
1	0	0	0	89.469kHz	20Hz
1	0	0	1	89.464kHz	25Hz
1	0	1	0	89.439kHz	50Hz
0	X	X	X	89.489kHz	0.0Hz
X	1	X	X	89.489kHz	0.0Hz

ELECTRICAL CHARACTERISTICS: Unless otherwise stated, these specifications hold for T_A = 0°C to 70°C for the UCC3751 and -40°C to +85°C for the UCC2751, $\bar{A} = T_J$.

PARAMETER	TEST CONDITIONS	MIN	TYP	MAX	UNITS
V12 Supply Current Section					
Supply Current	ENABLE = 0V		0.5	TBD	mA
	ENABLE = 5V		5		mA
Internal Reference with External Bypass Section					
Output Voltage (VDD)		4.85	5	5.15	V
Load Regulation	0mA ≤ I _{VDD} ≤ 2mA		5		mV
Line Regulation	10V < V _{S12} < 13V, I _{VDD} = 1mA		3		mV
Short Circuit Current	V _{DD} = 0	5	10		mA
Output Drivers Section (DRV1, DRV2)					
Pull Up Resistance			9	15	Ω
Pull Down Resistance			9	15	Ω
Rise Time	C _{LOAD} = 1nF		50	100	nS
Fall Time	C _{LOAD} = 1nF		50	100	nS
Output Drivers Section (DRVS)					
Pull Up Resistance			6	10	Ω
Pull Down Resistance			6	10	Ω
Sample Pulse-Width	Mode 1 and 2, (Note 1)		280		nS
Rise Time	C _{LOAD} = 1nF		50	100	nS
Fall Time	C _{LOAD} = 1nF		50	100	nS
Current Limit Section					
OHD Threshold			300		mV
OHD Input Current	V _{OHD} = 0V		-1		μA
DCLIM Threshold			300		mV
DCLIM Input Current	V _{DCLIM} = 0V		-1		μA
Frequency Section (Note 1)					
Primary Switching Frequency	All cases 3.579545 MHz Crystal		89489		Hz
Sampling Switching Frequency	FS0 = 0, FS1 = 0, Mode 1, (Note 1)		89469		Hz
	FS0 = 1, FS1 = 0, Mode 1		89464		Hz
	FS0 = 0, FS1 = 1, Mode 1		89439		Hz

ELECTRICAL CHARACTERISTICS: Unless otherwise stated, these specifications hold for $T_A = 0^\circ\text{C}$ to 70°C for the UCC3751 and -40°C to $+85^\circ\text{C}$ for the UCC2751, $\bar{I}_A = T_J$.

PARAMETER	TEST CONDITIONS	MIN	TYP	MAX	UNITS
Off-Hook Sampling Delay (Note 2)					
td0	$V_{\text{DELAY}} < 0.9\text{V}$		0		nS
td1	$1.1\text{V} < V_{\text{DELAY}} < 1.9\text{V}$		280		nS
td2	$2.1\text{V} < V_{\text{DELAY}} < 2.9\text{V}$		560		nS
td3	$3.1\text{V} < V_{\text{DELAY}} < 3.9\text{V}$		840		nS
td4	$4.1\text{V} < V_{\text{DELAY}}$		1120		nS

Note 1. Frequency setting is as shown in the Frequency Selectability Decoding Table. Sine Wave Frequency = Primary – Sampling Frequency.

Note 2. The delay function will delay the sample pulse from the rising edge of DRV2 to allow adjustment of the DC level provided during Mode 2.

PIN DESCRIPTIONS

DCLIM: Primary current sense input. Signal proportional to the primary switch current. All outputs are turned off when a threshold of 300mV is exceeded on this pin. This current limit works on a cycle-by-cycle basis.

DELAY: A resistive divider from VDD to GND is programmed and fed into DELAY pin. The voltage at this pin sets the phase difference between the sampling pulses and primary pulses under off-hook condition. By programming the delay, desired level of DC voltage can be attained at the ringer output when the OHD threshold is exceeded.

DRV1, DRV2: Low impedance driver outputs for the primary switches.

DRVS: Low impedance driver output for the sampling switch(es). The pulse width of this output is 280ns. Typically, a pulse transformer is used to couple the short sampling pulses at DRVS to the floating sampling switch(es).

ENABLE: Logic input which turns off the outputs when low.

FS0, FS1: Frequency select pins for determining the difference frequency between primary and secondary pulses under normal operation. These pins can be hard-wired to GND or VDD to get one of the available output

frequencies (20,25 and 50 Hz). See Note 1 in the spec table.

GND: Reference point for all the internal voltages and common return for the device.

OHD: Secondary current sense input. Voltage proportional to output current DC level is fed into this pin and compared to an internal threshold of 300mV. If the threshold is exceeded, the sampling scheme is changed to eliminate the AC component in the output voltage as required by the off-hook condition.

PGND: Return point for the output drivers. Connect to GND at a single point in the circuit.

RINGEN: Logic input used to determine when the ring signal is needed. When this signal is high and OHD low, normal ring signal is available at the output of the ring generator.

VDD: Internal regulated 5V supply. This voltage is used to power all the internal precision circuits of the IC. This pin needs to be bypassed to GND with ceramic capacitor.

VS12: External 12V power supply for the IC. Powers VDD and provides voltage for the output drivers.

XTAL1, XTAL2: Pins for connecting precision Crystal to attain the accurate output frequencies. An external square-wave pulse can also be applied to XTAL2 if XTAL1 is tied to VDD/2.

APPLICATION INFORMATION

Power Stage Operation

The power stage used for the UCC3751 application has two distinct switching circuits which together produce the required low frequency signal on the output. The primary side switching circuit consists of a current fed push-pull resonant circuit that generates the high frequency sinusoidal waveform across the transformer winding. The operation of this type of circuit is extensively covered in Unitrode Application notes U-141 and U-148. Resonant components C_{R1} , C_{R2} , L_R , N should be chosen so that the primary and secondary resonances are well matched. Also, for the UCC3751 operation, switching frequency is fixed by crystal selection. So, the resonant components must be selected to yield a resonant frequency close enough to the switching frequency to get a low distortion sine-wave. Practically, since it is impossible to get an exact match between the two frequencies, the switching frequency should always be higher than the resonant frequency to ensure low distortion and take advantage of ZVT operation. Switches Q1 and Q2 are pulsed at 50% duty cycle at the switching frequency (89.489 kHz) determined by a crystal (3.579545 MHz) connected to the UCC3751. The input voltage for the resonant stage (typically 12V) determines the voltage stress of Q1 and Q2. Transformer turns ratio is determined by the output voltage requirements. On the secondary side, the high frequency waveform is sampled at a predetermined frequency (e.g. 89.469 kHz) which differs from the primary switching frequency by the desired output frequency (e.g. 20 Hz). The sampling is accomplished using a bi-directional switching circuit as shown in Figure 2 and Figure 3. Figure 2 shows the sampling mechanism consisting of two back-to-back FET switches allowing current flow in both directions. The sampling can also be done with a single active switch and a full-bridge rectifier as shown in Fig. 3. The DRVS pin of the UCC3751 provides the drive signal for the sampling switch(es) and this signal is coupled through a pulse

transformer. Typical pulsewidth of the sampling signal is 280ns. As a result of sampling, the resultant output signal matches the secondary voltage in amplitude and has a low output frequency desired for ring generation.

The secondary winding of the power transformer also has a tap (or a separate winding) to generate a loosely regulated DC voltage. This DC voltage can be used to offset the ring generator output. The UCC3751 is also configured such that the AC output can go to zero under certain conditions. Table 2 provides the logic levels for different operating modes of UCC3751. Operation in mode 2 is achieved by altering the sampling frequency to match the switching frequency and sampling the secondary AC voltage at zero crossings. As a result, the resultant total output voltage between V_{OUT} and GND is the semi-regulated DC voltage achieved through the tapped secondary. This feature allows the circuit to operate under off-hook and idle conditions when only the DC portion of the voltage is required. The activation of this mode occurs when the OHD voltage exceeds a set threshold or RINGEN is low. The incorporation of this mode eliminates any need for external relays or switching circuits as well as eliminating the need for an additional power supply for powering the phone. The DC voltage level can be fine tuned by adjusting the voltage on the DELAY pin of the UCC3751. This pin sets the sampling delay time during the off-hook mode and allows a DC voltage to be developed between V_1 and V_{OUT} during this mode. Fig. 1 illustrates the operation of this mode. When the DELAY is set between 0 and 1V, the sampling is done in phase with the primary switching instances (at points A), leading to an average voltage of 0V between V_1 and V_{OUT} for a sinusoidal secondary signal. If DELAY is set to another level, the sampling instance shifts (e.g. to point B) leading to an effective voltage V_B being developed between V_1 and V_{OUT} . The actual V_{OUT} is the sum of V_B and the DC offset voltage derived from the additional (or tapped) winding (V_1).

Table II. Operating mode selection.

Condition	OHD	RINGEN	Sampling Output Mode
Continuous Ringing	Low	High	Frequency Offset from Primary (Mode 1)
Idle (On Hook, No Ringing)	Low	Low	Synchronized to Primary Frequency with Phase Controlled by DELAY (Mode 2)
Off-Hook	High	X (Low/High)	Mode 2
Cadenced Ringing	Low	High/Low	Mode 1/Mode 2

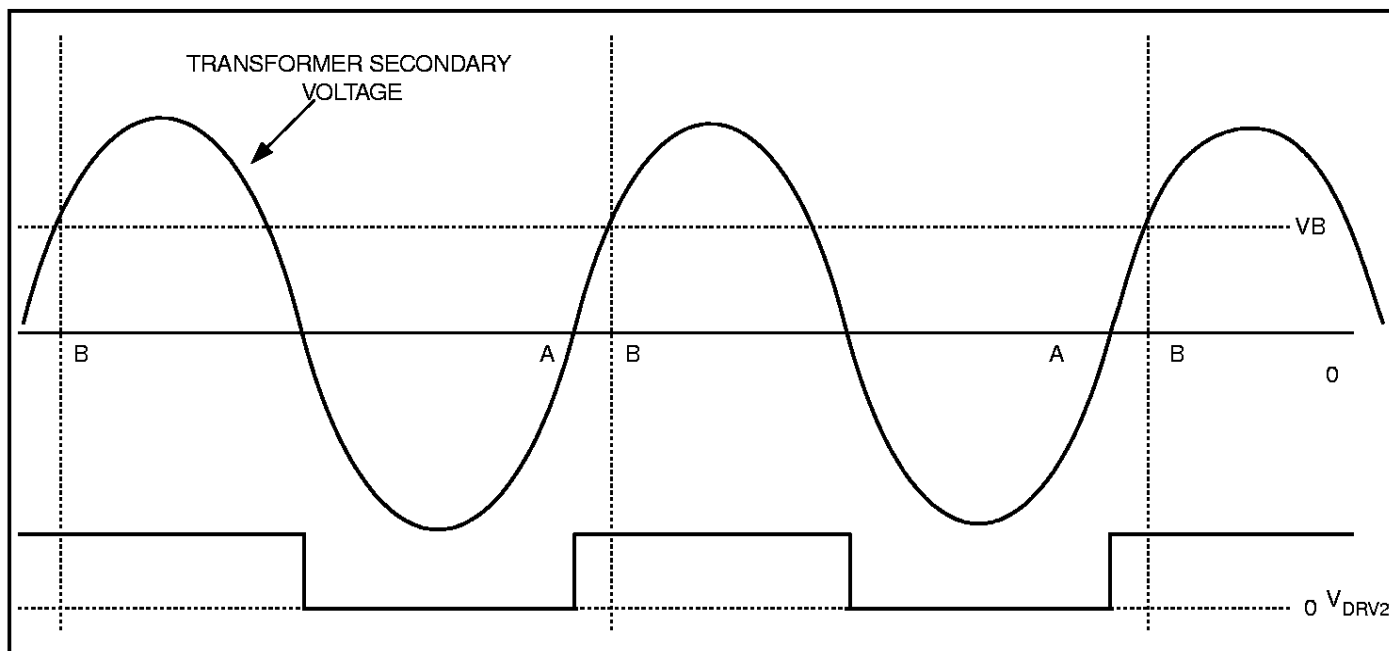

Figure 1. Effects of sampling delay during off-hook operation.

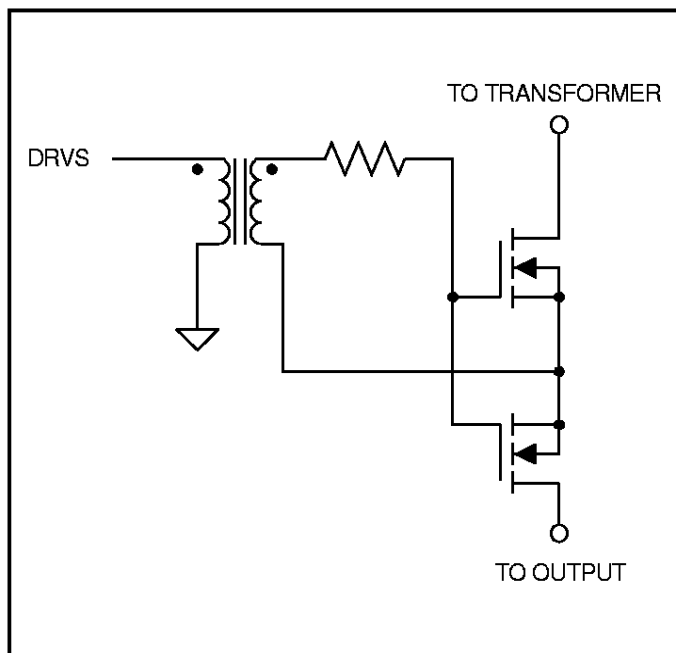

Figure 2. Sampling circuit with two FETs.

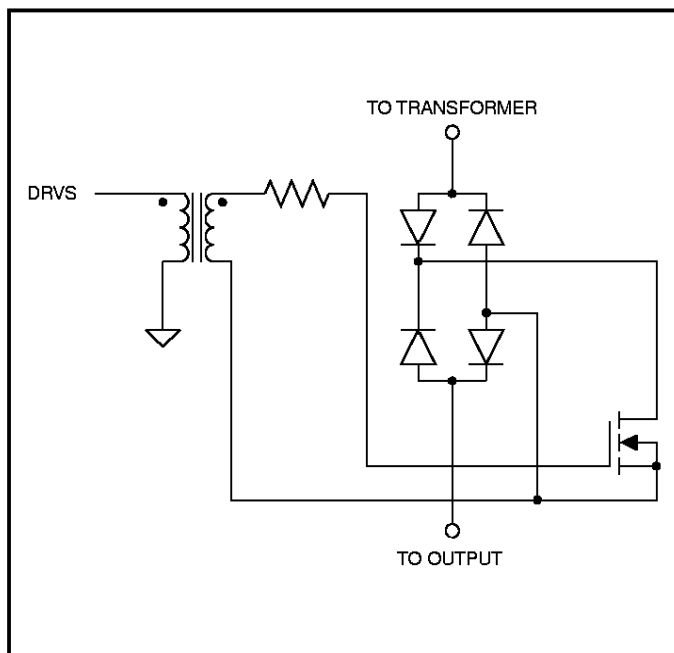

Figure 3. Sampling circuit with single FET and full-bridge rectifier.