

TL16C750 ASYNCHRONOUS COMMUNICATIONS ELEMENT WITH 64-BYTE FIFOs AND AUTOFLOW CONTROL

SLLS191C – JANUARY 1995 – REVISED DECEMBER 1997

- Pin-to-Pin Compatible With the Existing TL16C550B/C
- Programmable 16- or 64-Byte FIFOs to Reduce CPU Interrupts
- Programmable Auto- $\overline{\text{RTS}}$ and Auto- $\overline{\text{CTS}}$
- In Auto- $\overline{\text{CTS}}$ Mode, $\overline{\text{CTS}}$ Controls Transmitter
- In Auto- $\overline{\text{RTS}}$ Mode, Receiver FIFO Contents and Threshold Control $\overline{\text{RTS}}$
- Serial and Modem Control Outputs Drive a RJ11 Cable Directly When Equipment Is on the Same Power Drop
- Capable of Running With All Existing TL16C450 Software
- After Reset, All Registers Are Identical to the TL16C450 Register Set
- Up to 16-MHz Clock Rate for Up to 1-Mbaud Operation
- In the TL16C450 Mode, Hold and Shift Registers Eliminate the Need for Precise Synchronization Between the CPU and Serial Data
- Programmable Baud Rate Generator Allows Division of Any Input Reference Clock by 1 to $(2^{16} - 1)$ and Generates an Internal $16 \times$ Clock
- Standard Asynchronous Communication Bits (Start, Stop, and Parity) Added or Deleted to or From the Serial Data Stream
- 5-V and 3-V Operation
- Register Selectable Sleep Mode and Low-Power Mode
- Independent Receiver Clock Input
- Independently Controlled Transmit, Receive, Line Status, and Data Set Interrupts
- Fully Programmable Serial Interface Characteristics:
 - 5-, 6-, 7-, or 8-Bit Characters
 - Even-, Odd-, or No-Parity Bit Generation and Detection
 - 1-, 1 1/2-, or 2-Stop Bit Generation
 - Baud Generation (DC to 1 Mbits Per Second)
- False Start Bit Detection
- Complete Status Reporting Capabilities
- 3-State Output CMOS Drive Capabilities for Bidirectional Data Bus and Control Bus
- Line Break Generation and Detection
- Internal Diagnostic Capabilities:
 - Loopback Controls for Communications Link Fault Isolation
 - Break, Parity, Overrun, Framing Error Simulation
- Fully Prioritized Interrupt System Controls
- Modem Control Functions ($\overline{\text{CTS}}$, $\overline{\text{RTS}}$, $\overline{\text{DSR}}$, $\overline{\text{DTR}}$, $\overline{\text{RI}}$, and $\overline{\text{DCD}}$)
- Available in 44-Pin PLCC and 64-Pin SQFP
- Industrial Temperature Range Available for 64-Pin SQFP

description

The TL16C750 is a functional upgrade of the TL16C550C asynchronous communications element (ACE), which in turn is a functional upgrade of the TL16C450. Functionally equivalent to the TL16C450 on power up (character or TL16C450 mode), the TL16C750, like the TL16C550C, can be placed in an alternate mode (FIFO mode). This relieves the CPU of excessive software overhead by buffering received and transmitted characters. The receiver and transmitter FIFOs store up to 64 bytes including three additional bits of error status per byte for the receiver FIFO. The user can choose between a 16-byte FIFO mode or an extended 64-byte FIFO mode. In the FIFO mode, there is a selectable autoflow control feature that can significantly reduce software overload and increase system efficiency by automatically controlling serial data flow through the $\overline{\text{RTS}}$ output and the $\overline{\text{CTS}}$ input signals (see Figure 1).

The TL16C750 performs serial-to-parallel conversion on data received from a peripheral device or modem and parallel-to-serial conversion on data received from its CPU. The CPU can read the ACE status at any time. The ACE includes complete modem control capability and a processor interrupt system that can be tailored to minimize software management of the communications link.



Please be aware that an important notice concerning availability, standard warranty, and use in critical applications of Texas Instruments semiconductor products and disclaimers thereto appears at the end of this data sheet.

PRODUCTION DATA information is current as of publication date. Products conform to specifications per the terms of Texas Instruments standard warranty. Production processing does not necessarily include testing of all parameters.

 **TEXAS
INSTRUMENTS**

POST OFFICE BOX 655303 • DALLAS, TEXAS 75265

Copyright © 1997, Texas Instruments Incorporated

TL16C750

ASYNCHRONOUS COMMUNICATIONS ELEMENT

WITH 64-BYTE FIFOs AND AUTOFLOW CONTROL

SLLS191C – JANUARY 1995 – REVISED DECEMBER 1997

description (continued)

The TL16C750 ACE includes a programmable baud rate generator capable of dividing a reference clock by divisors from 1 to $(2^{16} - 1)$ and producing a $16\times$ reference clock for the internal transmitter logic. Provisions are also included to use this $16\times$ clock for the receiver logic. The ACE accommodates a 1-Mbaud serial rate (16-MHz input clock) so a bit time is $1\ \mu\text{s}$ and a typical character time is $10\ \mu\text{s}$ (start bit, 8 data bits, stop bit).

Two of the TL16C450 terminal functions have been changed to $\overline{\text{TXRDY}}$ and $\overline{\text{RXRDY}}$, which provide signaling to a direct memory access (DMA) controller.

FN PACKAGE
(TOP VIEW)

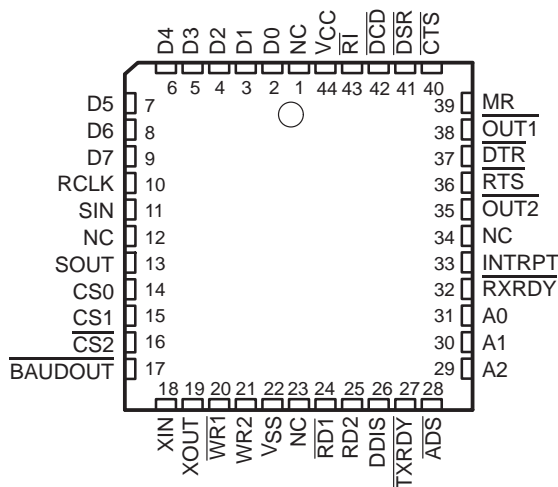

PM PACKAGE
(TOP VIEW)

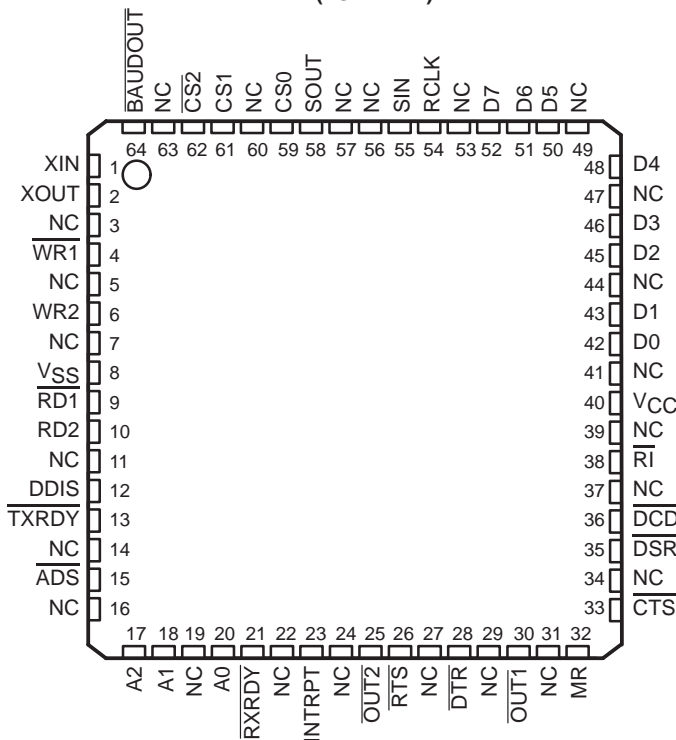

NC—No internal connection



POST OFFICE BOX 655303 • DALLAS, TEXAS 75265

TL16C750 ASYNCHRONOUS COMMUNICATIONS ELEMENT WITH 64-BYTE FIFOs AND AUTOFLOW CONTROL

SLLS191C – JANUARY 1995 – REVISED DECEMBER 1997

functional block diagram

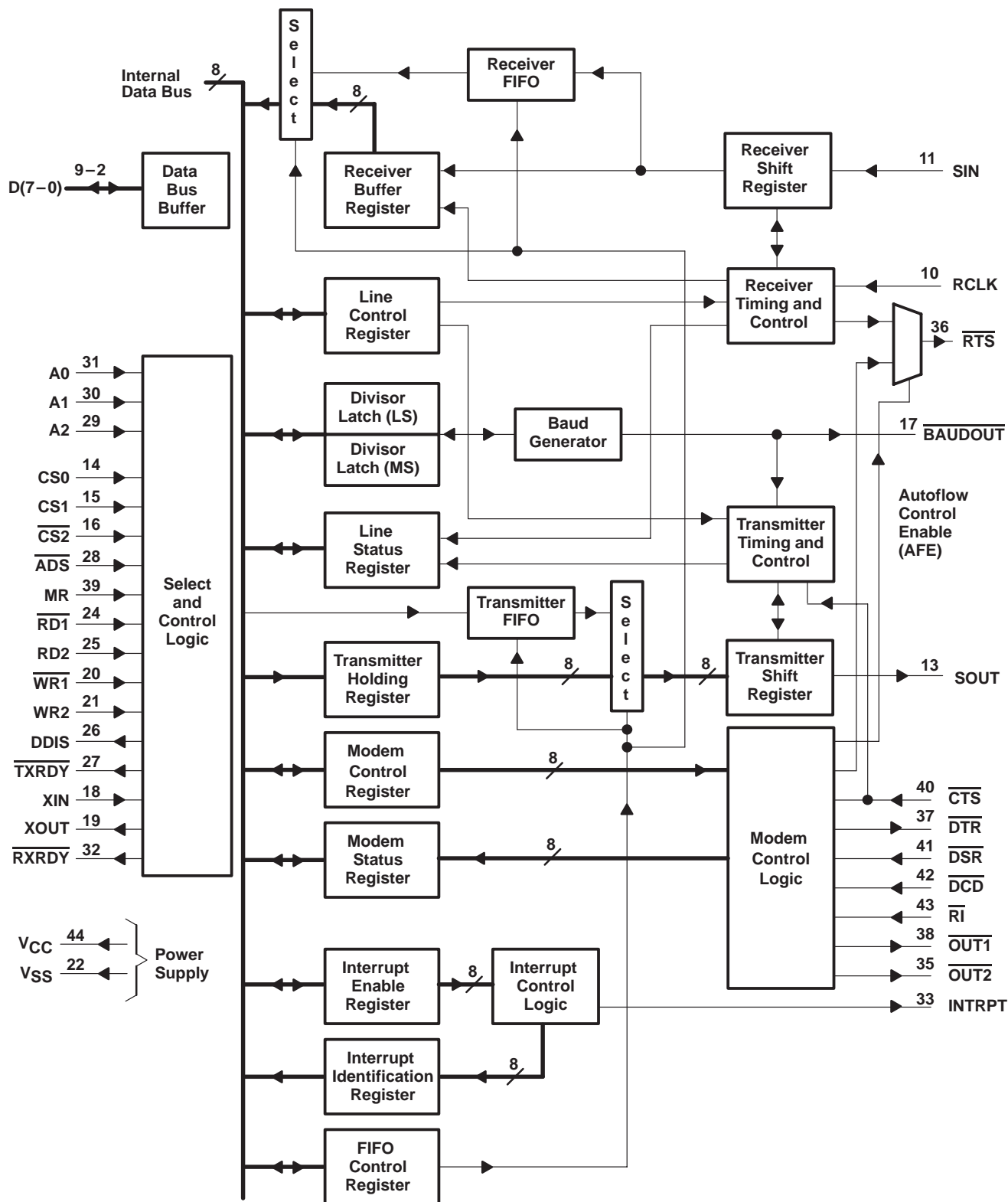

NOTE A: Terminal numbers shown are for the FN package.

TL16C750
ASYNCHRONOUS COMMUNICATIONS ELEMENT
WITH 64-BYTE FIFOs AND AUTOFLOW CONTROL

SLLS191C – JANUARY 1995 – REVISED DECEMBER 1997

Terminal Functions

TERMINAL			I/O	DESCRIPTION
NAME	NO. FN	NO. PM		
A0 A1 A2	31 30 29	20 18 17	I	Register select. A0–A2 are used during read and write operations to select the ACE register to read from or write to. Refer to Table 1 for register addresses and \overline{ADS} signal description.
\overline{ADS}	28	15	I	Address strobe. When \overline{ADS} is active (low), the register select signals (A0, A1, and A2) and chip select signals (CS0, CS1, $\overline{CS2}$) drive the internal select logic directly; when \overline{ADS} is high, the register select and chip select signals are held at the logic levels they were in when the low-to-high transition of \overline{ADS} occurred.
$\overline{BAUDOUT}$	17	64	O	Baud out. $\overline{BAUDOUT}$ is a 16×clock signal for the transmitter section of the ACE. The clock rate is established by the reference oscillator frequency divided by a divisor specified by the baud generator divisor latches. $\overline{BAUDOUT}$ can also be used for the receiver section by tying this output to RCLK.
CS0 CS1 $\overline{CS2}$	14 15 16	59 61 62	I	Chip select. When CS0 and CS1 are high and $\overline{CS2}$ is low, the ACE is selected. When any of these inputs are inactive, the ACE remains inactive. Refer to the \overline{ADS} signal description.
\overline{CTS}	40	33	I	Clear to send. \overline{CTS} is a modem status signal. Its condition can be checked by reading bit 4 (CTS) of the modem status register. Bit 0 (ΔCTS) of the modem status register indicates that \overline{CTS} has changed states since the last read from the modem status register. When the modem status interrupt is enabled, \overline{CTS} changes states, and the auto-CTS mode is not enabled, an interrupt is generated. \overline{CTS} is also used in the auto-CTS mode to control the transmitter.
D0 D1 D2 D3 D4 D5 D6 D7	2 3 4 5 6 7 8 9	42 43 45 46 48 50 51 52	I/O	Data bus. Eight data lines with 3-state outputs provide a bidirectional path for data, control, and status information between the ACE and the CPU. As inputs, they use fail safe CMOS compatible input buffers.
\overline{DCD}	42	36	I	Data carrier detect. \overline{DCD} is a modem status signal. Its condition can be checked by reading bit 7 (DCD) of the modem status register. Bit 3 (ΔDCD) of the modem status register indicates that \overline{DCD} has changed states since the last read from the modem status register. When the modem status interrupt is enabled and \overline{DCD} changes state, an interrupt is generated.
\overline{DDIS}	26	12	O	Driver disable. \overline{DDIS} is active (high) when the CPU is not reading data. When active, \overline{DDIS} can disable an external transceiver.
\overline{DSR}	41	35	I	Data set ready. \overline{DSR} is a modem status signal. Its condition can be checked by reading bit 5 (DSR) of the modem status register. Bit 1 (ΔDSR) of the modem status register indicates \overline{DSR} has changed states since the last read from the modem status register. When the modem status interrupt is enabled and the \overline{DSR} changes states, an interrupt is generated.
\overline{DTR}	37	28	O	Data terminal ready. When active (low), \overline{DTR} informs a modem or data set that the ACE is ready to establish communication. \overline{DTR} is placed in the active state by setting the DTR bit of the modem control register to one. \overline{DTR} is placed in the inactive condition either as a result of a master reset, during loop mode operation, or clearing the DTR bit.
INTRPT	33	23	O	Interrupt. When active (high), INTRPT informs the CPU that the ACE has an interrupt to be serviced. Four conditions that cause an interrupt to be issued are: a receiver error, received data that is available or timed out (FIFO mode only), an empty transmitter holding register, or an enabled modem status interrupt. INTRPT is reset (deactivated) either when the interrupt is serviced or as a result of a master reset.
MR	39	32	I	Master reset. When active (high), MR clears most ACE registers and sets the levels of various output signals (refer to Table 2).
$\overline{OUT1}$ $\overline{OUT2}$	38 35	30 25	O	Outputs 1 and 2. These are user-designated output terminals that are set to their active (low) level by setting their respective modem control register (MCR) bits (OUT1 and OUT2). $\overline{OUT1}$ and $\overline{OUT2}$ are set to their inactive (high) level as a result of master reset, during loop mode operations, or by clearing bit 2 (OUT1) or bit 3 (OUT2) of the MCR.
RCLK	10	54	I	Receiver clock. RCLK is the 16× baud rate clock for the receiver section of the ACE.



TL16C750
**ASYNCHRONOUS COMMUNICATIONS ELEMENT
 WITH 64-BYTE FIFOs AND AUTOFLOW CONTROL**

SLLS191C – JANUARY 1995 – REVISED DECEMBER 1997

Terminal Functions (Continued)

TERMINAL			I/O	DESCRIPTION
NAME	NO. FN	NO. PM		
$\overline{RD1}$ RD2	24 25	9 10	I	Read inputs. When either $\overline{RD1}$ or RD2 is active (low or high respectively) while the ACE is selected, the CPU is allowed to read status information or data from a selected ACE register. Only one of these inputs is required for the transfer of data during a read operation; the other input should be tied in its inactive state (i.e., RD2 tied low or $\overline{RD1}$ tied high).
\overline{RI}	43	38	I	Ring indicator. \overline{RI} is a modem status signal. Its condition can be checked by reading bit 6 (RI) of the modem status register. Bit 2 (TERI) of the modem status register indicates that \overline{RI} has transitioned from a low to a high level since the last read from the modem status register. If the modem status interrupt is enabled when this transition occurs, an interrupt is generated.
\overline{RTS}	36	26	O	Request to send. When active, \overline{RTS} informs the modem or data set that the ACE is ready to receive data. \overline{RTS} is set to its active level by setting the RTS MCR bit and is set to its inactive (high) level either as a result of a master reset, during loop mode operations, or by clearing bit 1 (RTS) of the MCR. In the auto- \overline{RTS} mode, \overline{RTS} is set to its inactive level by the receiver threshold control logic.
\overline{RXRDY}	32	21	O	Receiver ready. Receiver direct memory access (DMA) signalling is available with \overline{RXRDY} . When operating in the FIFO mode, one of two types of DMA signalling can be selected through the FIFO control register bit 3 (FCR3). When operating in the TL16C450 mode, only DMA mode 0 is allowed. Mode 0 supports single-transfer DMA in which a transfer is made between CPU bus cycles. Mode 1 supports multitransfer DMA in which multiple transfers are made continuously until the receiver FIFO has been emptied. In DMA mode 0 (FCR0 = 0 or FCR0 = 1, FCR3 = 0), when there is at least one character in the receiver FIFO or receiver holding register, \overline{RXRDY} is active (low). When \overline{RXRDY} has been active but there are no characters in the FIFO or holding register, \overline{RXRDY} goes inactive (high). In DMA mode 1 (FCR0 = 1, FCR3 = 1), when the trigger level or the timeout has been reached, \overline{RXRDY} goes active (low); when it has been active but there are no more characters in the FIFO or holding register, it goes inactive (high).
SIN	11	55	I	Serial data. SIN is the input from a connected communications device.
SOUT	13	58	O	Composite serial data output to a connected communication device. SOUT is set to the marking (high) level as a result of master reset.
\overline{TXRDY}	27	13	O	Transmitter ready. Transmitter DMA signalling is available with \overline{TXRDY} . When operating in the FIFO mode, one of two types of DMA signalling can be selected through FCR3. When operating in the TL16C450 mode, only DMA mode 0 is allowed. Mode 0 supports single-transfer DMA in which a transfer is made between CPU bus cycles. Mode 1 supports multitransfer DMA in which multiple transfers are made continuously until the transmit FIFO has been filled.
VCC	44	40		5-V supply voltage
VSS	22	8		Supply common
$\overline{WR1}$ $\overline{WR2}$	20 21	4 6	I	Write inputs. When either input is active (low or high respectively) and while the ACE is selected, the CPU is allowed to write control words or data into a selected ACE register. Only one of these inputs is required to transfer data during a write operation; the other input should be tied in its inactive state (i.e., $\overline{WR2}$ tied low or $\overline{WR1}$ tied high).
XIN XOUT	18 19	1 2	I/O	External clock. XIN and XOUT connect the ACE to the main timing reference (clock or crystal).

detailed description

autoflow control

Auto-flow control is composed of auto-CTS and auto-RTS. With auto-CTS, \overline{CTS} must be active before the transmit FIFO can emit data (see Figure 1). With auto-RTS, \overline{RTS} becomes active when the receiver is empty or the threshold has not been reached. When \overline{RTS} is connected to \overline{CTS} , data transmission does not occur unless the receive FIFO has empty space. Thus, overrun errors are eliminated when ACE1 and ACE2 are TLC16C750s with enabled autoflow control. If not, overrun errors occur if the transmit data rate exceeds the receive FIFO read latency.



TL16C750
ASYNCHRONOUS COMMUNICATIONS ELEMENT
WITH 64-BYTE FIFOs AND AUTOFLOW CONTROL

SLLS191C – JANUARY 1995 – REVISED DECEMBER 1997

autoflow control (continued)

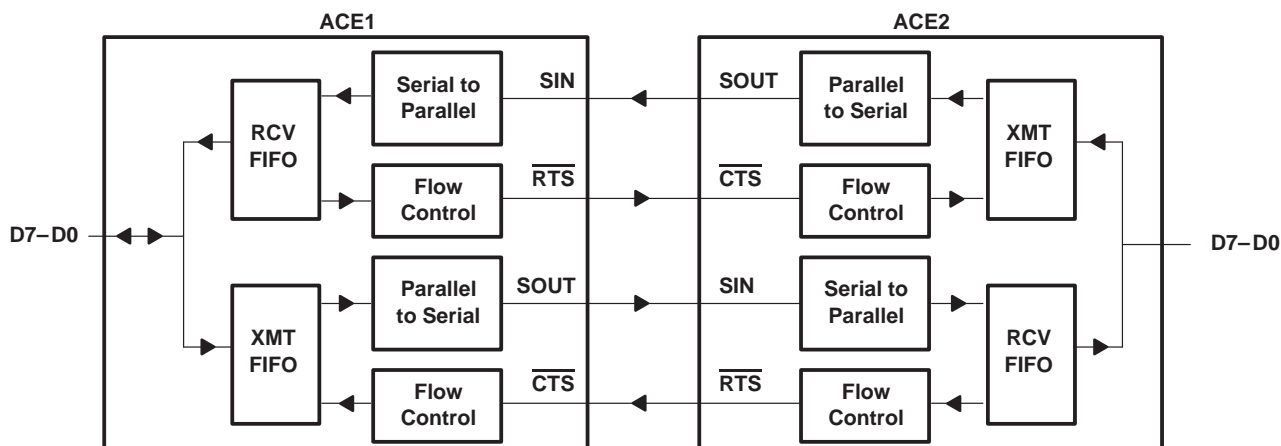

Figure 1. Autoflow Control (auto-RTS and auto-CTS) Example

auto-RTS (see Figure 1)

Auto-RTS data flow control originates in the receiver timing and control block (see functional block diagram) and is linked to the programmed receiver FIFO trigger level. When the receiver FIFO level reaches a trigger level of 1, 4, 8, or 14 in 16-byte mode or 1, 16, 32, or 56 in 64-byte mode, $\overline{\text{RTS}}$ is deasserted. The sending ACE may send an additional byte after the trigger level is reached (assuming the sending ACE has another byte to send) because it may not recognize the deassertion of $\overline{\text{RTS}}$ until after it has begun sending the additional byte. $\overline{\text{RTS}}$ is automatically reasserted once the receiver FIFO is emptied by reading the receiver buffer register. The reassertion signals the sending ACE to continue transmitting data.

auto-CTS (see Figure 1)

The transmitter circuitry checks $\overline{\text{CTS}}$ before sending the next data byte. When $\overline{\text{CTS}}$ is active, the transmitter sends the next byte. To stop the transmitter from sending the following byte, $\overline{\text{CTS}}$ must be released before the middle of the last stop bit that is currently being sent. The auto-CTS function reduces interrupts to the host system. When flow control is enabled, the $\overline{\text{CTS}}$ state changes and does not trigger host interrupts because the device automatically controls its own transmitter. Without auto-CTS, the transmitter sends any data present in the transmit FIFO and a receiver overrun error can result.

enabling auto-RTS and auto-CTS

The auto-RTS and auto-CTS modes of operation are activated by setting bit 5 of the modem control register (MCR) to 1 (see Figure 2).



- NOTES:
- A. When $\overline{\text{CTS}}$ is low, the transmitter keeps sending serial data out.
 - B. When $\overline{\text{CTS}}$ goes high before the middle of the last stop bit of the current byte, the transmitter finishes sending the current byte but it does not send the next byte.
 - C. When $\overline{\text{CTS}}$ goes from high to low, the transmitter begins sending data again.

Figure 2. CTS Functional Timing



enabling auto-RTS and auto-CTS (continued)

The receiver FIFO trigger level can be set to 1, 4, 8, or 14 bytes for the 16-byte mode and 1, 16, 32, or 56 bytes for 64-byte mode (see Figure 3).

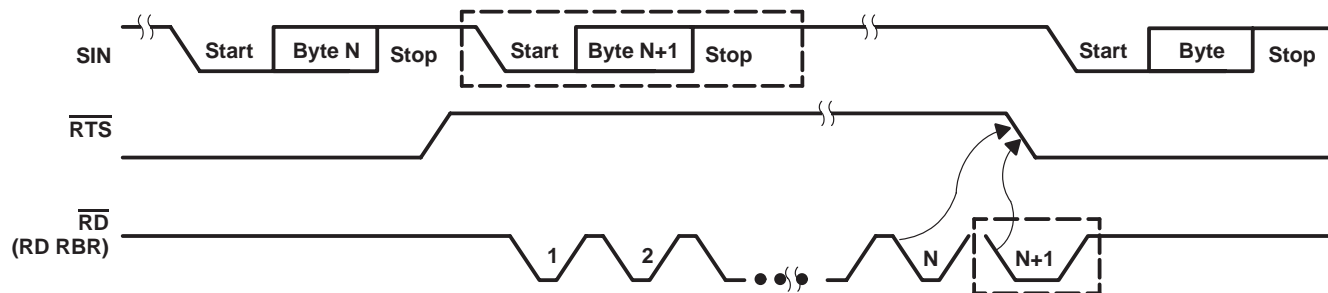

- NOTES: A. N = receiver FIFO trigger level
 B. The two blocks in dashed lines cover the case where an additional byte is sent as described in auto-RTS.

Figure 3. RTS Functional Timing, Receiver FIFO Trigger Level

absolute maximum ratings over operating free-air temperature range (unless otherwise noted)†

Supply voltage range, V_{CC} (see Note 1)	-0.5 V to 6 V
Input voltage range, V_I : Standard	-0.5 V to $V_{CC} + 0.5$ V
Fail safe	-0.5 V to 6.5 V
Output voltage range, V_O : Standard	-0.5 V to $V_{CC} + 0.5$ V
Fail safe	-0.5 V to 6.5 V
Input clamp current, I_{IK} ($V_I < 0$ or $V_I > V_{CC}$) (see Note 1)	± 20 mA
Output clamp current, I_{OK} ($V_O < 0$ or $V_O > V_{CC}$) (see Note 2)	± 20 mA
Operating free-air temperature range, T_A	0°C to 70°C
Operating free-air temperature range, T_A (TL16C750I)	-40°C to 85°C
Storage temperature range, T_{stg}	-65°C to 150°C

† Stresses beyond those listed under “absolute maximum ratings” may cause permanent damage to the device. These are stress ratings only, and functional operation of the device at these or any other conditions beyond those indicated under “recommended operating conditions” is not implied. Exposure to absolute-maximum-rated conditions for extended periods may affect device reliability.

- NOTES: 1. This applies for external input and bidirectional buffers. $V_I > V_{CC}$ does not apply to fail safe terminals.
 2. This applies for external output and bidirectional buffers. $V_O > V_{CC}$ does not apply to fail safe terminals.

TL16C750

ASYNCHRONOUS COMMUNICATIONS ELEMENT WITH 64-BYTE FIFOs AND AUTOFLOW CONTROL

SLLS191C – JANUARY 1995 – REVISED DECEMBER 1997

recommended operating conditions

low voltage (3.3 V nominal)

	MIN	NOM	MAX	UNIT
Supply voltage, V_{CC}	3	3.3	3.6	V
Input voltage, V_I	0		V_{CC}	V
High-level input voltage, V_{IH} (see Note 3)	$0.7 V_{CC}$			V
Low-level input voltage, V_{IL} (see Note 3)			$0.3 V_{CC}$	V
Output voltage, V_O (see Note 4)	0		V_{CC}	V
High-level output current, I_{OH} (all outputs)			1.8	mA
Low-level output current, I_{OL} (all outputs)			3.2	mA
Input capacitance, c_I			1	pF
Operating free-air temperature, T_A	0	25	70	°C
Junction temperature range, T_J (see Note 5)	0	25	115	°C
Oscillator/clock speed			14	MHz

- NOTES: 3. Meets TTL levels, $V_{IHmin} = 2\text{ V}$ and $V_{ILmax} = 0.8\text{ V}$ on nonhysteresis inputs
 4. Applies for external output buffers
 5. These junction temperatures reflect simulated conditions. Absolute maximum junction temperature is 150°C. The customer is responsible for verifying junction temperature.

standard voltage (5 V nominal)

	MIN	NOM	MAX	UNIT
Supply voltage, V_{CC}	4.75	5	5.25	V
Input voltage, V_I	0		V_{CC}	V
High-level input voltage, V_{IH}	$0.7 V_{CC}$			V
Low-level input voltage, V_{IL}			$0.2 V_{CC}$	V
Output voltage, V_O (see Note 4)	0		V_{CC}	V
High-level output current, I_{OH} (all outputs)			4	mA
Low-level output current, I_{OL} (all outputs)			4	mA
Input capacitance, c_I			1	pF
Operating free-air temperature, T_A	0	25	70	°C
Junction temperature range, T_J (see Note 5)	0	25	115	°C
Oscillator/clock speed			16	MHz

- NOTES: 4. Applies for external output buffers
 5. These junction temperatures reflect simulated conditions. Absolute maximum junction temperature is 150°C. The customer is responsible for verifying junction temperature.

electrical characteristics over recommended ranges of supply voltage and operating free-air temperature (unless otherwise noted)

low voltage (3.3 V nominal)

PARAMETER		TEST CONDITIONS	MIN	MAX	UNIT
V _{OH}	High-level output voltage†	I _{OH} = -1.8 mA	V _{CC} - 0.55		V
V _{OL}	Low-level output voltage†	I _{OL} = 3.2 mA		0.5	V
I _{OZ}	High-impedance 3-state output current (see Note 6)	V _I = V _{CC} or GND		±10	μA
I _{IL}	Low-level input current (see Note 7)	V _I = GND		-1	μA
I _{IH}	High-level input current (see Note 8)	V _I = V _{CC}		1	μA

† For all outputs except XOUT

- NOTES: 6. The 3-state or open-drain output must be in the high-impedance state.
 7. Specifications only apply with pullup termination turned off.
 8. Specifications only apply with pulldown termination turned off.

standard voltage (5 V nominal)

PARAMETER		TEST CONDITIONS	MIN	MAX	UNIT
V _{OH}	High-level output voltage†	I _{OH} = -4 mA	V _{CC} - 0.8		V
V _{OL}	Low-level output voltage†	I _{OL} = 4 mA		0.5	V
I _{OZ}	High-impedance 3-state output current (see Note 6)	V _I = V _{CC} or GND		±10	μA
I _{IL}	Low-level input current (see Note 7)	V _I = GND		-1	μA
I _{IH}	High-level input current (see Note 8)	V _I = V _{CC}		1	μA

† For all outputs except XOUT

- NOTES: 6. The 3-state or open-drain output must be in the high-impedance state.
 7. Specifications only apply with pullup termination turned off.
 8. Specifications only apply with pulldown termination turned off.

TL16C750

ASYNCHRONOUS COMMUNICATIONS ELEMENT WITH 64-BYTE FIFOs AND AUTOFLOW CONTROL

SLLS191C – JANUARY 1995 – REVISED DECEMBER 1997

system timing requirements over recommended ranges of supply voltage and operating free-air temperature

PARAMETER	ALT. SYMBOL	FIGURE	TEST CONDITIONS	MIN	MAX	UNIT
t _{cR} Cycle time, read (t _{w7} + t _{d8} + t _{d9})	RC			87		ns
t _{cW} Cycle time, write (t _{w6} + t _{d5} + t _{d6})	WC			87		ns
t _{w1} Pulse duration, clock (XIN) high	t _{XH}	4	f = 16 MHz maximum	25		ns
t _{w2} Pulse duration, clock (XIN) low	t _{XL}	4	f = 16 MHz maximum	25		ns
t _{w5} Pulse duration, $\overline{\text{ADS}}$ low	t _{ADS}	5, 6		9		ns
t _{w6} Pulse duration, write strobe	t _{WR}	5		40		ns
t _{w7} Pulse duration, read strobe	t _{RD}	6		40		ns
t _{w8} Pulse duration, MR	t _{MR}			1		μs
t _{su1} Setup time, address valid before $\overline{\text{ADS}}\uparrow$	t _{AS}	5, 6		8		ns
t _{su2} Setup time, CS valid before $\overline{\text{ADS}}\uparrow$	t _{CS}	5, 6		8		ns
t _{su3} Setup time, data valid before $\overline{\text{WR}}1\downarrow$ or $\overline{\text{WR}}2\uparrow$	t _{DS}	5		15		ns
t _{su4} [†] Setup time, $\overline{\text{CTS}}\uparrow$ before midpoint of stop bit		16			10	ns
t _{h1} Hold time, address low after $\overline{\text{ADS}}\uparrow$	t _{AH}	5, 6		0		ns
t _{h2} Hold time, CS valid after $\overline{\text{ADS}}\uparrow$	t _{CH}	5, 6		0		ns
t _{h3} Hold time, CS valid after $\overline{\text{WR}}1\uparrow$ or $\overline{\text{WR}}2\downarrow$	t _{WCS}	5		10		ns
t _{h4} [†] Hold time, address valid after $\overline{\text{WR}}1\uparrow$ or $\overline{\text{WR}}2\downarrow$	t _{WA}	5		10		ns
t _{h5} Hold time, data valid after $\overline{\text{WR}}1\uparrow$ or $\overline{\text{WR}}2\downarrow$	t _{DH}	5		5		ns
t _{h6} Hold time, CS valid after $\overline{\text{RD}}1\uparrow$ or $\overline{\text{RD}}2\downarrow$	t _{RCS}	6		10		ns
t _{h7} [†] Hold time, address valid after $\overline{\text{RD}}1\uparrow$ or $\overline{\text{RD}}2\downarrow$	t _{RA}	6		20		ns
t _{d4} [†] Delay time, CS valid before $\overline{\text{WR}}1\downarrow$ or $\overline{\text{WR}}2\uparrow$	t _{CSW}	5		7		ns
t _{d5} Delay time, address valid before $\overline{\text{WR}}1\downarrow$ or $\overline{\text{WR}}2\uparrow$	t _{AW}	5		7		ns
t _{d6} [†] Delay time, write cycle, $\overline{\text{WR}}1\uparrow$ or $\overline{\text{WR}}2\downarrow$ to $\overline{\text{ADS}}\downarrow$	t _{WC}	5		40		ns
t _{d7} [†] Delay time, CS valid to $\overline{\text{RD}}1\downarrow$ or $\overline{\text{RD}}2\uparrow$	t _{CSR}	6		7		ns
t _{d8} [†] Delay time, address valid to $\overline{\text{RD}}1\downarrow$ or $\overline{\text{RD}}2\uparrow$	t _{AR}	6		7		ns
t _{d9} Delay time, read cycle, $\overline{\text{RD}}1\uparrow$ or $\overline{\text{RD}}2\downarrow$ to $\overline{\text{ADS}}\downarrow$	t _{RC}	6		40		ns
t _{d10} Delay time, $\overline{\text{RD}}1\downarrow$ or $\overline{\text{RD}}2\uparrow$ to data valid	t _{RVD}	6	C _L = 75 pF	45		ns
t _{d11} Delay time, $\overline{\text{RD}}1\uparrow$ or $\overline{\text{RD}}2\downarrow$ to floating data	t _{HZ}	6	C _L = 75 pF	20		ns

[†] Only applies when $\overline{\text{ADS}}$ is low

system switching characteristics over recommended ranges of supply voltage and operating free-air temperature (see Note 9)

PARAMETER	ALT. SYMBOL	FIGURE	TEST CONDITIONS	MIN	MAX	UNIT
t _{dis(R)} Disable time, $\overline{\text{RD}}1\downarrow\uparrow$ or $\overline{\text{RD}}2\downarrow\uparrow$ to $\overline{\text{DDIS}}\uparrow\downarrow$	t _{RDD}	6	C _L = 75 pF	20		ns

NOTE 9: Charge and discharge times are determined by V_{OL}, V_{OH}, and external loading.

baud generator switching characteristics over recommended ranges of supply voltage and operating free-air temperature, C_L = 75 pF

PARAMETER	ALT. SYMBOL	FIGURE	TEST CONDITIONS	MIN	MAX	UNIT
t _{w3} Pulse duration, $\overline{\text{BAUDOUT}}$ low	t _{LW}	4	f = 16 MHz, CLK ÷ 2	50		ns
t _{w4} Pulse duration, $\overline{\text{BAUDOUT}}$ high	t _{HW}	4	f = 16 MHz, CLK ÷ 2	50		ns
t _{d1} Delay time, XIN [†] to $\overline{\text{BAUDOUT}}\uparrow$	t _{BLD}	4			45	ns
t _{d2} Delay time, XIN [†] to $\overline{\text{BAUDOUT}}\downarrow$	t _{BHD}	4			45	ns



TL16C750
ASYNCHRONOUS COMMUNICATIONS ELEMENT
WITH 64-BYTE FIFOs AND AUTOFLOW CONTROL

SLLS191C – JANUARY 1995 – REVISED DECEMBER 1997

commercial maximum switching characteristics, $V_{CC} = 4.75\text{ V}$, $T_J = 115^\circ\text{C}$

PARAMETER	FROM (INPUT)	TO (OUTPUT)	INTRINSIC DELAY (ns)	DELTA DELAY (ns/pF)	DELAY (ns)			
					$C_L = 15\text{ pF}$	$C_L = 50\text{ pF}$	$C_L = 85\text{ pF}$	$C_L = 100\text{ pF}$
t_{PLH}	XIN	XO	-0.92	0.571	7.65	27.66	47.66	56.23
t_{PHL}			-0.79	0.312	3.89	14.83	25.76	30.45
t_r	Output rise time, XO				10.86	40.42	69.98	82.65
t_f	Output fall time, XO				5.47	20.90	36.34	42.95

commercial maximum switching characteristics, $V_{CC} = 3\text{ V}$, $T_J = 115^\circ\text{C}$

PARAMETER	FROM (INPUT)	TO (OUTPUT)	INTRINSIC DELAY (ns)	DELTA DELAY (ns/pF)	DELAY (ns)			
					$C_L = 15\text{ pF}$	$C_L = 50\text{ pF}$	$C_L = 85\text{ pF}$	$C_L = 100\text{ pF}$
t_{PLH}	XIN	XO	-4.69	1.017	10.57	46.16	81.75	97.00
t_{PHL}			-3.05	0.442	3.58	19.04	34.51	41.13
t_r	Output rise time, XO				14.39	64.87	115.35	136.98
t_f	Output fall time, XO				5.06	26.53	48.01	57.21

receiver switching characteristics over recommended ranges of supply voltage and operating free-air temperature (see Note 10)

PARAMETER	ALT. SYMBOL	FIGURE	TEST CONDITIONS	MIN	MAX	UNIT
t_{d12} Delay time, RCLK to sample clock	t_{SCD}	7			10	ns
t_{d13} Delay time, stop to set receiver error interrupt or read RBR to LSI interrupt or stop to $\overline{\text{RXRDY}}\downarrow$	t_{SINT}	7, 8, 9, 10, 11			2	RCLK cycle
t_{d14} Delay time, read RBR/LSR low to reset interrupt low	t_{RINT}	7, 8, 9, 10, 11	$C_L = 75\text{ pF}$		120	ns

NOTE 10: In the FIFO mode, the read cycle (RC) = 425 ns (minimum) between reads of the receive FIFO and the status registers (interrupt identification register or line status register).

transmitter switching characteristics over recommended ranges of supply voltage and operating free-air temperature

PARAMETER†	ALT. SYMBOL	FIGURE	TEST CONDITIONS	MIN	MAX	UNIT
t_{d15} Delay time, INTRPT to transmit start	t_{IRS}	12		8	24	baudout cycles
t_{d16} Delay time, start to interrupt	t_{STI}	12		8	10	baudout cycles
t_{d17} Delay time, WR THR to reset interrupt	t_{HR}	12	$C_L = 75\text{ pF}$		50	ns
t_{d18} Delay time, initial write to interrupt (THRE)	t_{SI}	12		16	34	baudout cycles
t_{d19} Delay time, read IIR to reset interrupt (THRE)	t_{IR}	12	$C_L = 75\text{ pF}$		70	ns
t_{d20} Delay time, write to $\overline{\text{TXRDY}}$ inactive	t_{WXI}	13, 14	$C_L = 75\text{ pF}$		75	ns
t_{d21} Delay time, start to $\overline{\text{TXRDY}}$ active	t_{SXA}	13, 14	$C_L = 75\text{ pF}$		9	baudout cycles

† THRE = transmitter holding register empty, IIR = interrupt identification register.



TL16C750
ASYNCHRONOUS COMMUNICATIONS ELEMENT
WITH 64-BYTE FIFOs AND AUTOFLOW CONTROL

SLLS191C – JANUARY 1995 – REVISED DECEMBER 1997

modem control switching characteristics over recommended ranges of supply voltage and operating free-air temperature, $C_L = 75 \text{ pF}$

PARAMETER	ALT. SYMBOL	FIGURE	MIN	MAX	UNIT
t_{d22} Delay time, WR MCR to output	t_{MDO}	15		60	ns
t_{d23} Delay time, modem interrupt to set interrupt	t_{SIM}	15		35	ns
t_{d24} Delay time, RD MSR to reset interrupt	t_{RIM}	15		45	ns
t_{d25} Delay time, \overline{CTS} low to SOUT \downarrow		16		24	baudout cycles
t_{d26} Delay time, receiver threshold byte to $\overline{RTS}\uparrow$		17		2	baudout cycles
t_{d27} Delay time, read of last byte in receive FIFO to $\overline{RTS}\downarrow$		17		3	baudout cycles

PARAMETER MEASUREMENT INFORMATION

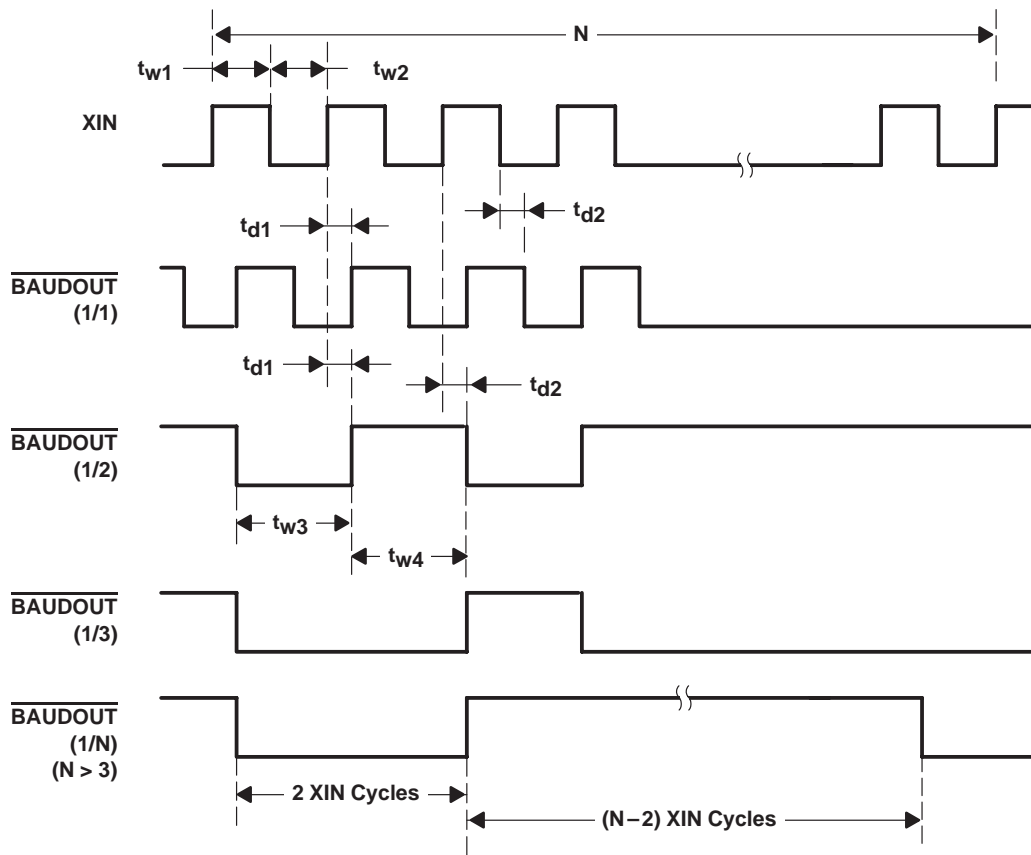

Figure 4. Baud Generator Timing Waveforms

PARAMETER MEASUREMENT INFORMATION

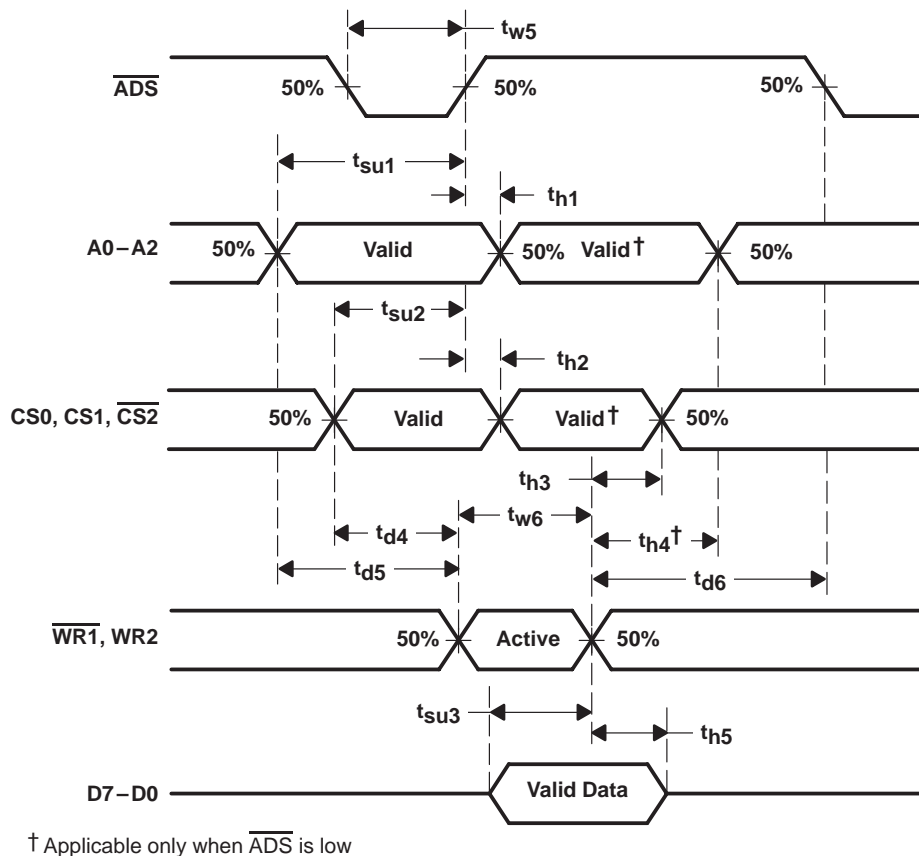

Figure 5. Write Cycle Timing Waveforms

PARAMETER MEASUREMENT INFORMATION

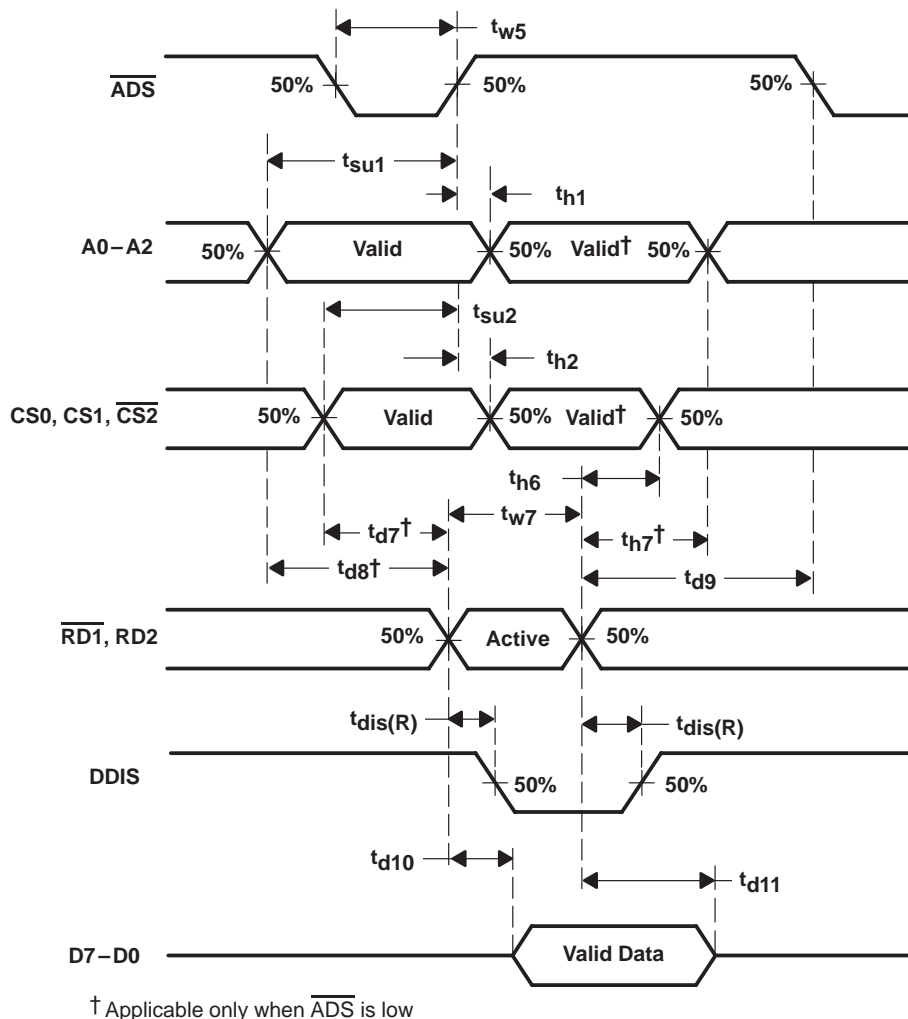

Figure 6. Read Cycle Timing Waveforms

PARAMETER MEASUREMENT INFORMATION

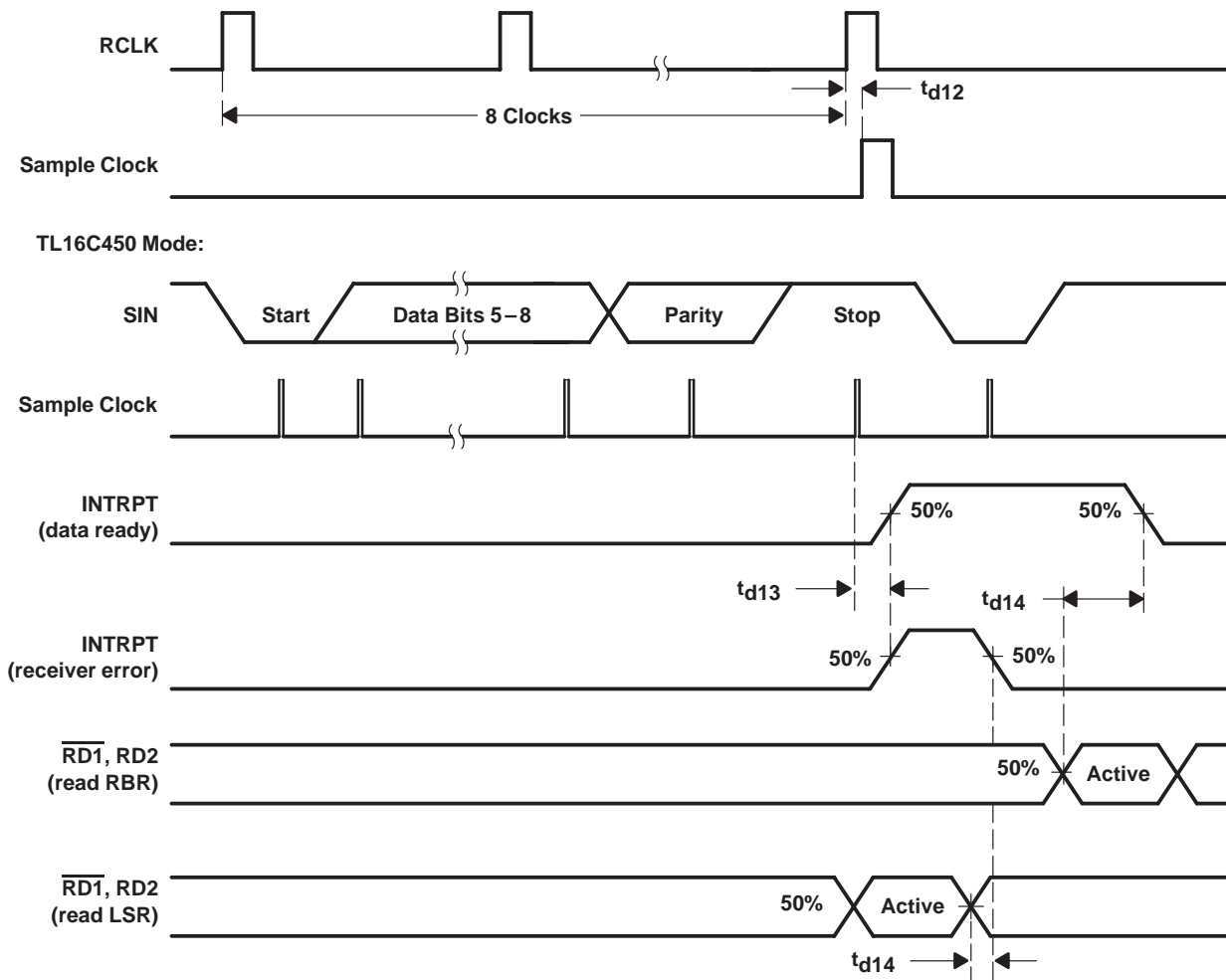
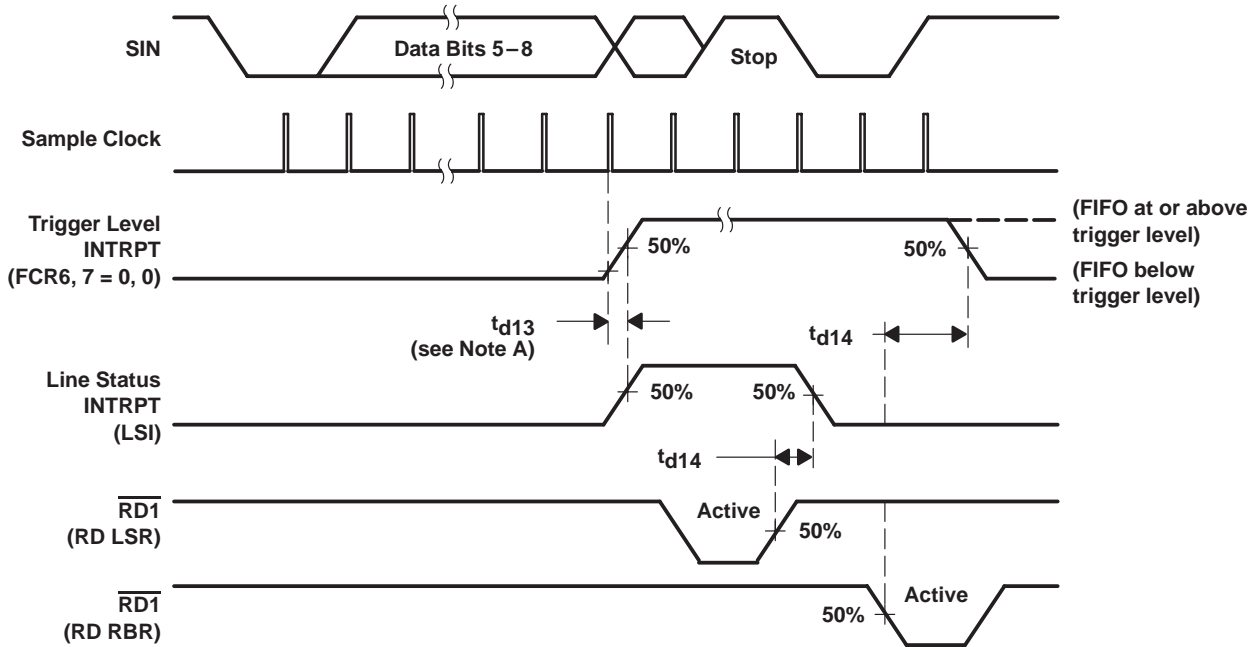

Figure 7. Receiver Timing Waveforms

TL16C750
ASYNCHRONOUS COMMUNICATIONS ELEMENT
WITH 64-BYTE FIFOs AND AUTOFLOW CONTROL

SLLS191C – JANUARY 1995 – REVISED DECEMBER 1997

PARAMETER MEASUREMENT INFORMATION



NOTE A: For a time-out interrupt, $t_{d13} = 9$ RCLKs.

Figure 8. Receive FIFO First Byte (Sets DR Bit) Waveforms

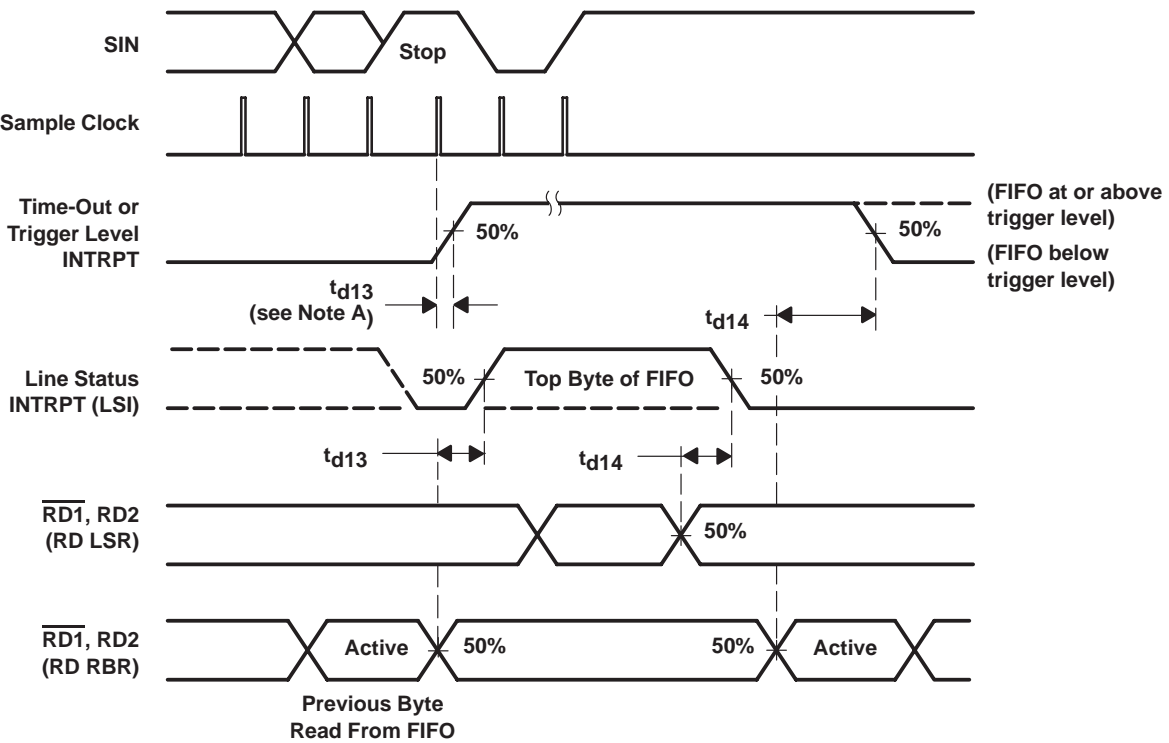

NOTE A: For a time-out interrupt, $t_{d13} = 9$ RCLKs.

Figure 9. Receive FIFO Bytes Other Than the First Byte (DR Internal Bit Already Set) Waveforms



POST OFFICE BOX 655303 • DALLAS, TEXAS 75265

PARAMETER MEASUREMENT INFORMATION

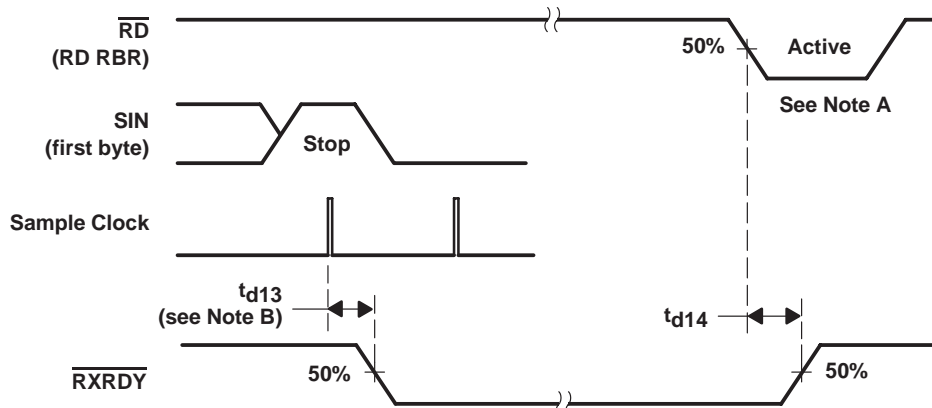

NOTES: A. This is the reading of the last byte in the FIFO.
 B. For a time-out interrupt, $t_{d13} = 9$ RCLKs.

Figure 10. Receiver Ready ($\overline{\text{RXRDY}}$) Waveforms, $\text{FCR0} = 0$ or $\text{FCR0} = 1$ and $\text{FCR3} = 0$ (Mode 0)

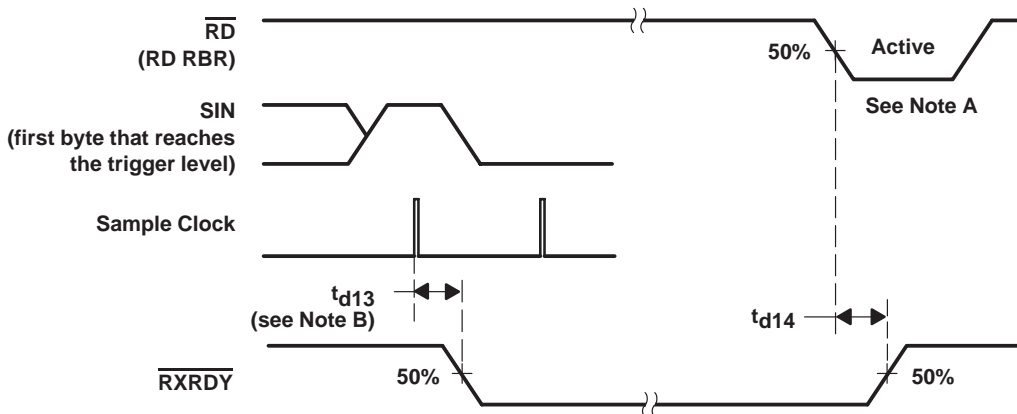

NOTES: A. This is the reading of the last byte in the FIFO.
 B. For a time-out interrupt, $t_{d13} = 9$ RCLKs.

Figure 11. Receiver Ready ($\overline{\text{RXRDY}}$) Waveforms, $\text{FCR0} = 1$ and $\text{FCR3} = 1$ (Mode 1)

PARAMETER MEASUREMENT INFORMATION

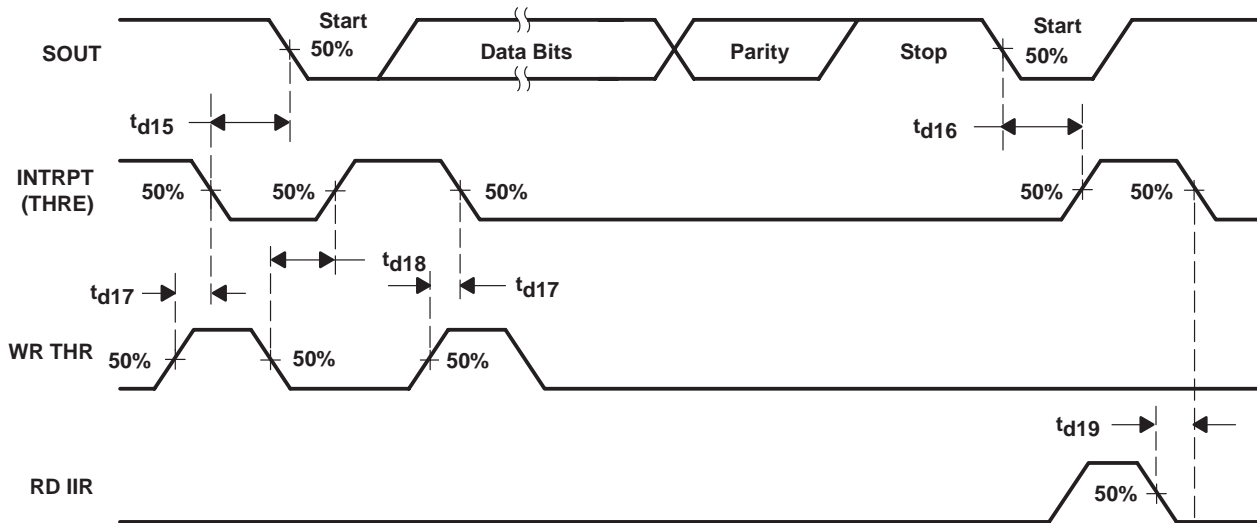

Figure 12. Transmitter Timing Waveforms

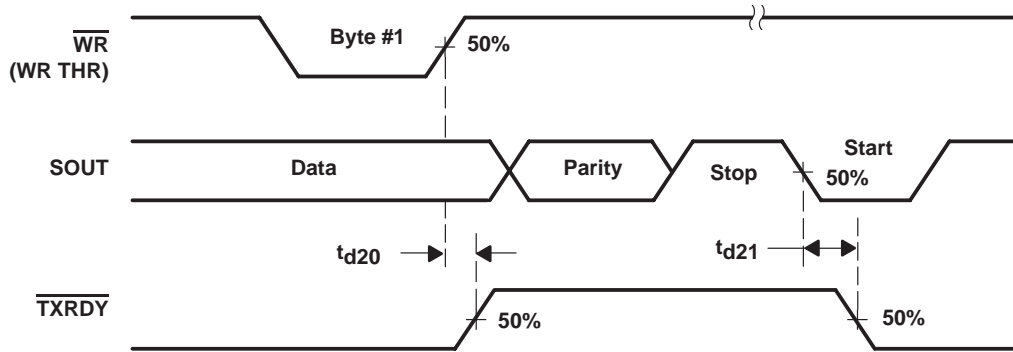

Figure 13. Transmitter Ready ($\overline{\text{TXRDY}}$) Waveforms, FCR0 = 0 or FCR0 = 1 and FCR3 = 0 (Mode 0)

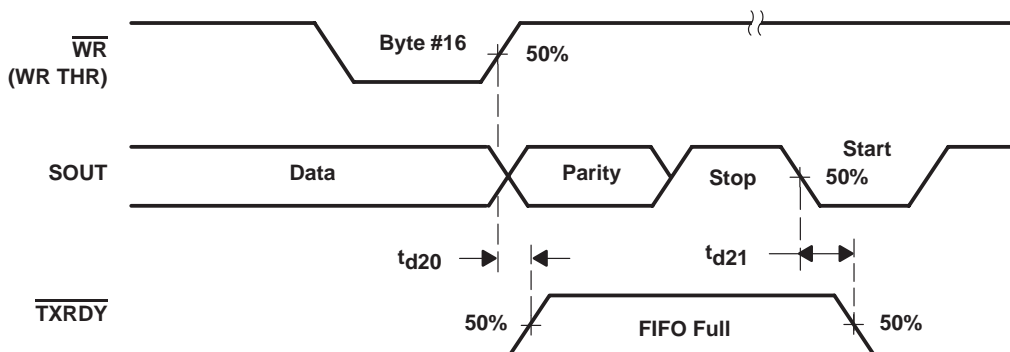

Figure 14. Transmitter Ready ($\overline{\text{TXRDY}}$) Waveforms, FCR0 = 1 and FCR3 = 1 (Mode 1)

PARAMETER MEASUREMENT INFORMATION

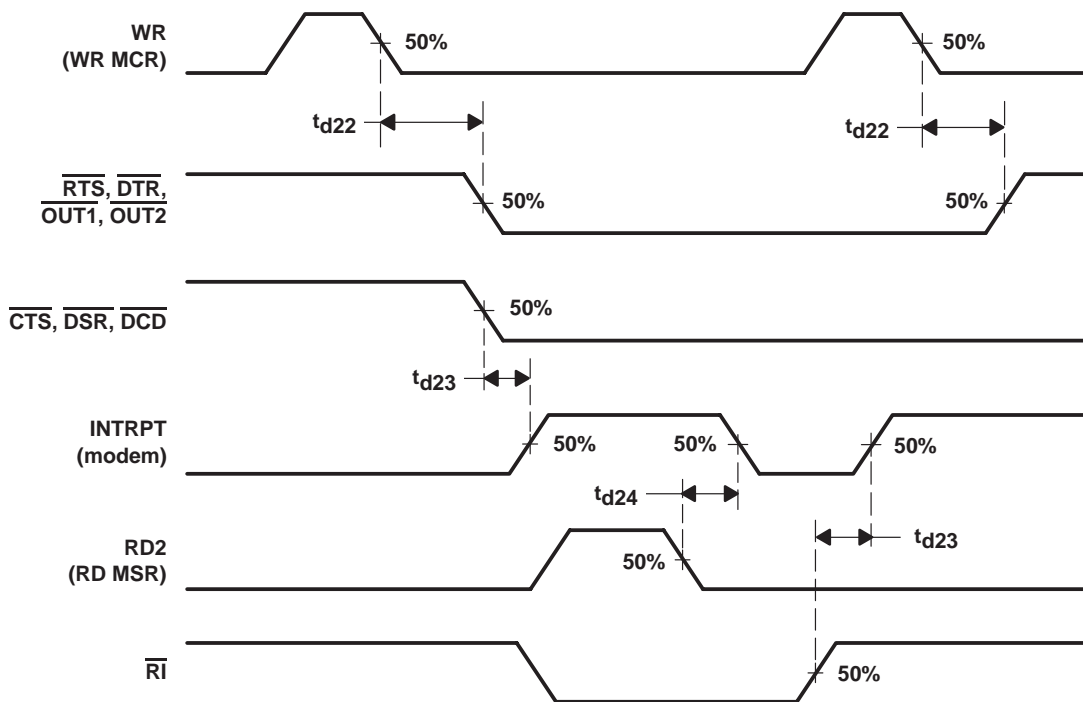

Figure 15. Modem Control Timing Waveforms

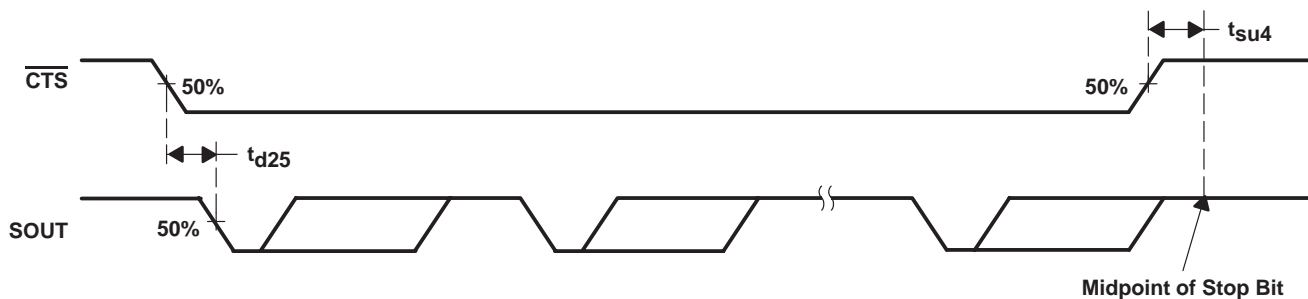

Figure 16. $\overline{\text{CTS}}$ and SOUT Autoflow Control Timing (Start and Stop) Waveforms

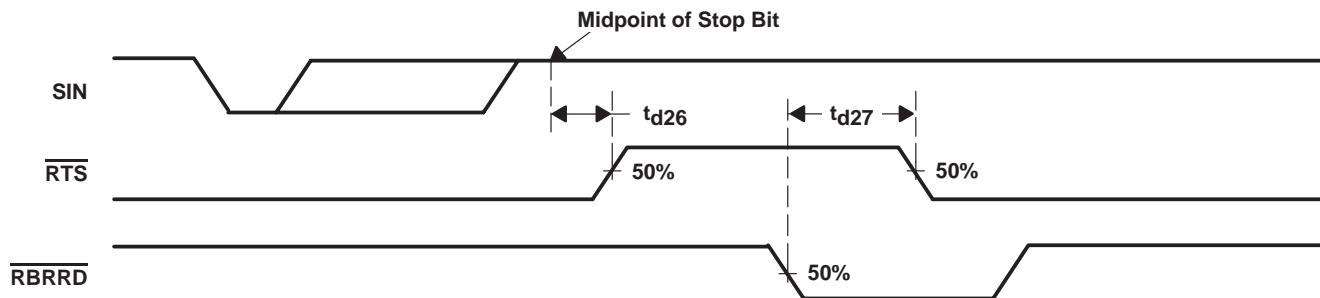

Figure 17. Auto-RTS Timing for Receiver Threshold at All Trigger Levels Waveforms

TL16C750
ASYNCHRONOUS COMMUNICATIONS ELEMENT
WITH 64-BYTE FIFOs AND AUTOFLOW CONTROL

SLLS191C – JANUARY 1995 – REVISED DECEMBER 1997

PARAMETER MEASUREMENT INFORMATION

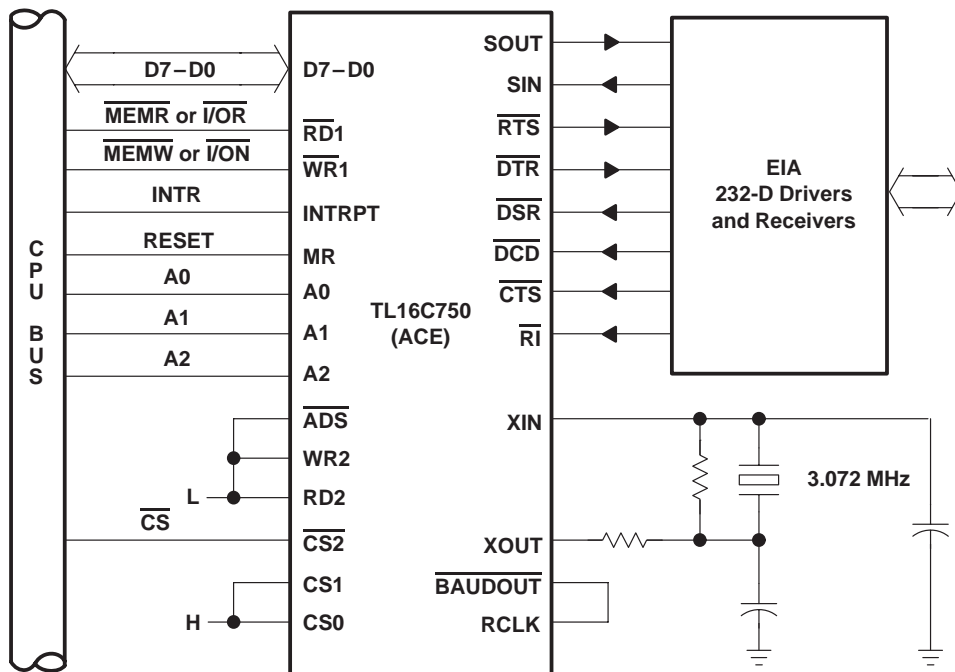

Figure 18. Basic TL16C750 Configuration

APPLICATION INFORMATION

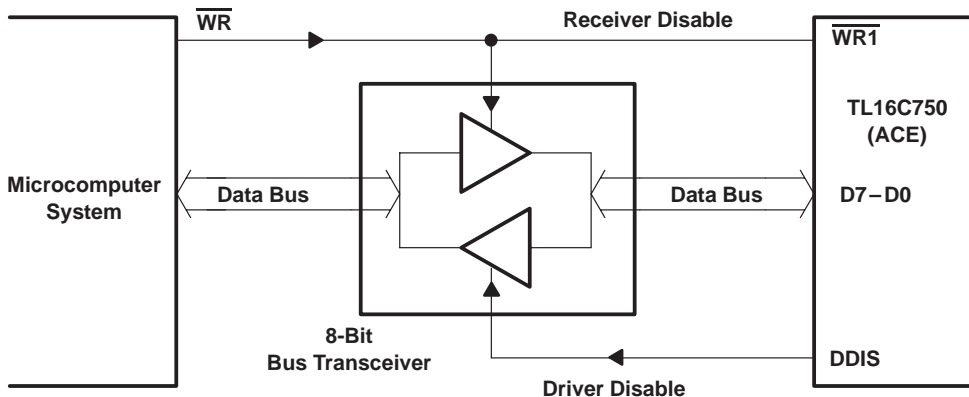
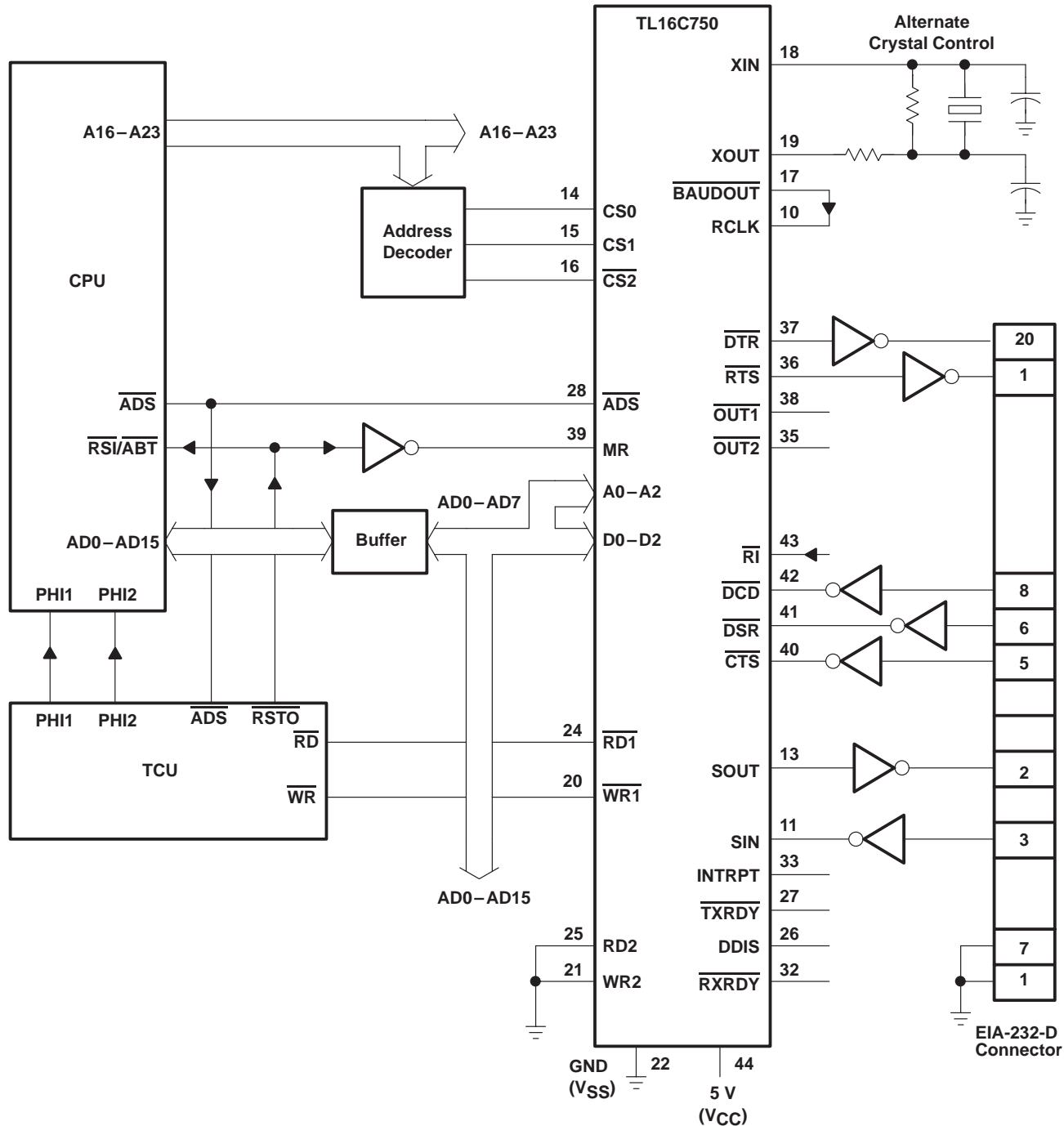

Figure 19. Typical Interface for a High-Capacity Data Bus

APPLICATION INFORMATION



NOTE A: Terminal numbers shown are for the FN package.

Figure 20. Typical TL16C750 Connection to a CPU

TL16C750
ASYNCHRONOUS COMMUNICATIONS ELEMENT
WITH 64-BYTE FIFOs AND AUTOFLOW CONTROL

SLLS191C – JANUARY 1995 – REVISED DECEMBER 1997

PRINCIPLES OF OPERATION

Table 1. Register Selection

DLAB†	A2	A1	A0	REGISTER
0	L	L	L	Receiver buffer (read), transmitter holding register (write)
0	L	L	H	Interrupt enable register
X	L	H	L	Interrupt identification register (read only)
X	L	H	L	FIFO control register (write)
X	L	H	H	Line control register
X	H	L	L	Modem control register
X	H	L	H	Line status register
X	H	H	L	Modem status register
X	H	H	H	Scratch register
1	L	L	L	Divisor latch (LSB)
1	L	L	H	Divisor latch (MSB)

† The divisor latch access bit (DLAB) is the most significant bit of the line control register. The DLAB signal is controlled by writing to this bit location (see Table 3).

Table 2. ACE Reset Functions

REGISTER/SIGNAL	RESET CONTROL	RESET STATE
Interrupt Enable Register	Master Reset	All bits cleared (0–5 forced and 6–7 permanent)
Interrupt Identification Register	Master Reset	Bit 0 is set, bits 1–4 are cleared, and bits 5–7 are cleared
FIFO Control Register	Master Reset	All bits cleared
Line Control Register	Master Reset	All bits cleared
Modem Control Register	Master Reset	All bits cleared (6–7 permanent)
Line Status Register	Master Reset	Bits 5 and 6 are set, all other bits are cleared
Modem Status Register	Master Reset	Bits 0–3 are cleared, bits 4–7 are input signals
SOUT	Master Reset	High
INTRPT (receiver error flag)	Read LSR/MR	Low
INTRPT (received data available)	Read RBR/MR	Low
INTRPT (transmitter holding register empty)	Read IR/Write THR/MR	Low
INTRPT (modem status changes)	Read MSR/MR	Low
$\overline{\text{OUT2}}$	Master Reset	High
$\overline{\text{RTS}}$	Master Reset	High
$\overline{\text{DTR}}$	Master Reset	High
$\overline{\text{OUT1}}$	Master Reset	High
Scratch Register	Master Reset	No effect
Divisor Latch (LSB and MSB) Registers	Master Reset	No effect
Receiver Buffer Registers	Master Reset	No effect
Transmitter Holding Registers	Master Reset	No effect
Receiver FIFO	MR/FCR1–FCR0/ Δ FCR0	All bits cleared
XMIT FIFO	MR/FCR2–FCR0/ Δ FCR0	All bits cleared



PRINCIPLES OF OPERATION

accessible registers

The system programmer, through the CPU, has access to and control over any of the ACE registers. These registers control ACE operations, receive data, and transmit data. Descriptions of these registers follow in Table 3.

Table 3. Summary of Accessible Registers

Bit No.	REGISTER ADDRESS											
	0DLAB=0	0DLAB=0	1DLAB=0	2	2	3	4	5	6	7	0DLAB=1	1DLAB=1
	Receiver Buffer Register (Read Only)	Transmitter Holding Register (Write Only)	Interrupt Enable Register	Interrupt Ident. Register (Read Only)	FIFO Control Register (Write Only)	Line Control Register	Modem Control Register	Line Status Register	Modem Status Register	Scratch Register	Divisor Latch (LSB)	Latch (MSB)
	RBR	THR	IER	IIR	FCR	LCR	MCR	LSR	MSR	SCR	DLL	DLM
0	Data Bit 0†	Data Bit 0	Enable Received Data Available Interrupt (ERBI)	0 when interrupt Pending	FIFO Enable	Word Length Select Bit 0 (WLS0)	Data Terminal Ready (DTR)	Data Ready (DR)	Delta Clear to Send (ΔCTS)	Bit 0	Bit 0	Bit 8
1	Data Bit 1	Data Bit 1	Enable Transmitter Holding Register Empty Interrupt (ETBEI)	Interrupt ID Bit 1	Receiver FIFO Reset	Word Length Select Bit 1 (WLS1)	Request to Send (RTS)	Overrun Error (OE)	Delta Data Set Ready (ΔDSR)	Bit 1	Bit 1	Bit 9
2	Data Bit 2	Data Bit 2	Enable Receiver Line Status Interrupt (ELSI)	Interrupt ID Bit 2	Transmitter FIFO Reset	Number of Stop Bits (STB)	OUT1	Parity Error (PE)	Trailing Edge Ring Indicator (TERI)	Bit 2	Bit 2	Bit 10
3	Data Bit 3	Data Bit 3	Enable Modem Status Interrupt (EDSSI)	Interrupt ID Bit 2 (see Note 4)	DMA Mode Select	Parity Enable (PEN)	OUT2	Framing Error (FE)	Delta Data Carrier Detect (ΔDCD)	Bit 3	Bit 3	Bit 11
4	Data Bit 4	Data Bit 4	Sleep Mode Enable	0	Reserved	Even Parity Select (EPS)	Loop	Break Interrupt (BI)	Clear to Send (CTS)	Bit 4	Bit 4	Bit 12
5	Data Bit 5	Data Bit 5	Low Power Mode Enable	64 Byte FIFO Enabled	64 Byte FIFO Enable‡	Stick Parity	Flow Control Enable (AFE)	Transmitter Holding Register (THRE)	Data Set Ready (DSR)	Bit 5	Bit 5	Bit 13
6	Data Bit 6	Data Bit 6	0	FIFOs Enabled (see Note 11)	Receiver Trigger (LSB)	Break Control	0	Transmitter Empty (TEMT)	Ring Indicator (RI)	Bit 6	Bit 6	Bit 14
7	Data Bit 7	Data Bit 7	0	FIFOs Enabled (see Note 11)	Receiver Trigger (MSB)	Divisor Latch Access Bit (DLAB)‡	0	Error in Receiver FIFO (see Note 12)	Data Carrier Detect (DCD)	Bit 7	Bit 7	Bit 15

† Bit 0 is the least significant bit. It is the first bit serially transmitted or received.

‡ Access to DLAB LSB, MSB, and FCR bit 5 require LCR bit 7 = 1

NOTE 11: These bits are always 0 in the TL16C450 mode.

PRINCIPLES OF OPERATION

FIFO control register (FCR)

The FCR is a write-only register at the same location as the IIR, which is a read-only register. The FCR enables the FIFOs, clears the FIFOs, sets the receiver FIFO trigger level, and selects the type of DMA signaling.

- Bit 0: FCR0 when set enables the transmit and receive FIFOs. This bit must be set when other FCR bits are written to or they are not programmed. Changing this bit clears the FIFOs.
- Bit 1: FCR1 when set clears all bytes in the receiver FIFO and resets its counter. The RSR is not cleared. The logic 1 that is written to this bit position is self clearing.
- Bit 2: FCR2 when set clears all bytes in the transmit FIFO and resets its counter to 0. The TSR is not cleared. The logic 1 that is written to this bit position is self clearing.
- Bit 3: When FCR0 is set, setting FCR3 causes the $\overline{\text{RXRDY}}$ and $\overline{\text{TXRDY}}$ to change from mode 0 to mode 1.
- Bit 4: Reserved for future use.
- Bit 5: When this bit is set 64-byte mode of operation is selected. When cleared, the 16-byte mode is selected. A write to FCR bit 5 is protected by setting the line control register (LCR) bit 7 = 1. LCR bit 7 needs to be cleared for normal operation.
- Bits 6 and 7: FCR6 and FCR7 set the trigger level for the receiver FIFO interrupt (see Table 4).

Table 4. Receiver FIFO Trigger Level

BIT 7	BIT 6	16-BYTE RECEIVER FIFO TRIGGER LEVEL (BYTES)	64-BYTE RECEIVER FIFO TRIGGER LEVEL (BYTES)
0	0	01	01
0	1	04	16
1	0	08	32
1	1	14	56

FIFO interrupt mode operation

When the receiver FIFO and receiver interrupts are enabled (FCR0 = 1, IER0 = 1, IER2 = 1), a receiver interrupt occurs as follows:

1. The received data available interrupt is issued to the microprocessor when the FIFO has reached its programmed trigger level. It is cleared when the FIFO drops below its programmed trigger level.
2. The IIR receive data available indication also occurs when the FIFO trigger level is reached, and as the interrupt, is cleared when the FIFO drops below the trigger level.
3. The receiver line status interrupt (IIR = 06 or 0110h) has higher priority than the received data available (IIR = 04) interrupt.
4. The data ready bit (LSR0) is set when a character is transferred from the shift register to the receiver FIFO. It is cleared when the FIFO is empty.

When the receiver FIFO and receiver interrupts are enabled:



PRINCIPLES OF OPERATION

FIFO interrupt mode operation (continued)

1. FIFO time-out interrupt occurs when the following conditions exist:
 - a. At least one character is in the FIFO.
 - b. The most recent serial character was received more than four continuous character times ago (if two stop bits are programmed, the second one is included in this time delay).
 - c. The most recent microprocessor read of the FIFO occurred more than four continuous character times ago. This causes a maximum character received to interrupt an issued delay of 160 ms at 300 baud with a 12-bit character.
2. Character times are calculated by using RCLK for a clock signal (makes the delay proportional to the baud rate).
3. When a time-out interrupt has occurred, the FIFO interrupt is cleared. The timer is reset when the microprocessor reads one character from the receiver FIFO. When a time-out interrupt has not occurred, the time-out timer is reset after a new character is received or after the microprocessor reads the receiver FIFO.

When the transmitter FIFO and THRE interrupt are enabled ($FCR0 = 1$, $IER1 = 1$), transmit interrupts occur as follows:

1. The transmitter holding register interrupt [$IIR(3-0) = 2$] occurs when the transmit FIFO is empty. The transmit FIFO is cleared [$IIR(3-0) = 1$] when the THR is written to (1 to 16 characters may be written to the transmit FIFO while servicing this interrupt) or the IIR is read.
2. The transmit FIFO empty indicator ($LSR5(THRE) = 1$) is delayed one character time minus the last stop bit time when there have not been at least two bytes in the transmit FIFO at the same time since the last time that $THRE = 1$. The first transmitter interrupt after changing $FCR0$ is immediate when it is enabled.

Character time-out and receiver FIFO trigger level interrupts have the same priority as the current received data available interrupt; transmit FIFO empty has the same priority as the current THRE interrupt.

FIFO polled mode operation

With $FCR0 = 1$ (transmitter and receiver FIFOs enabled), clearing $IER0$, $IER1$, $IER2$, $IER3$, or all four to 0 puts the ACE in the FIFO polled mode of operation. Since the receiver and transmitter are controlled separately, either one or both can be in the polled mode of operation.

In this mode, the user program checks receiver and transmitter status using the LSR. As stated previously:

- $LSR0$ is set when there is at least one byte in the receiver FIFO.
- $LSR(1-4)$ specify which error(s) have occurred. Character error status is handled the same way as when in the interrupt mode; the IIR is not affected since $IER2 = 0$.
- $LSR5$ indicates when the THR is empty.
- $LSR6$ indicates that both the THR and TSR are empty.
- $LSR7$ indicates whether there are any errors in the receiver FIFO.

There is no trigger level reached or time-out condition indicated in the FIFO polled mode. However, the receiver and transmitter FIFOs are still fully capable of holding characters.

PRINCIPLES OF OPERATION

interrupt enable register (IER)

The IER enables each of the five types of interrupts (refer to Table 5) and the INTRPT signal in response to an interrupt generation. The IER can also disable the interrupt system by clearing bits 0 through 3. The contents of this register are summarized in Table 3 and are described in the following bulleted list.

- Bit 0: When set, this bit enables the received data available interrupt.
- Bit 1: When set, this bit enables the THRE interrupt.
- Bit 2: When set, this bit enables the receiver line status interrupt.
- Bit 3: When set, this bit enables the modem status interrupt.
- Bit 4: When set, this bit enables sleep mode. The ACE is always awake when there is a byte in the transmitter, activity on the SIN, or when the device is in the loopback mode. The ACE is also awake when either Δ CTS, Δ DSR, Δ DCD, or TERI = 1. Bit 4 must be set to enable sleep mode.
- Bit 5: When set, this bit enables low-power mode. Low-power mode functions similar to sleep mode. However, this feature powers down the clock to the ACE only, while keeping the oscillator running. Bit 5 must be set to enable low-power mode.
- Bits 6 and 7: Not used (always cleared)

interrupt identification register (IIR)

The ACE has an on-chip interrupt generation and prioritization capability that permits a flexible interface with most popular microprocessors.

The ACE provides four prioritized levels of interrupts:

- Priority 1 – Receiver line status (highest priority)
- Priority 2 – Receiver data ready or receiver character timeout
- Priority 3 – Transmitter holding register empty
- Priority 4 – Modem status (lowest priority)

When an interrupt is generated, the IIR indicates that an interrupt is pending and provides the type of interrupt in its three least significant bits (bits 0, 1, and 2). The contents of this register are summarized in Table 3 and described in Table 5. Details on each bit are as follows:

- Bit 0: This bit can be used either in a hardwire prioritized, or polled interrupt system. When this bit is cleared, an interrupt is pending. When bit 0 is set, no interrupt is pending.
- Bits 1 and 2: Used to identify the highest priority interrupt pending as indicated in Table 3.
- Bit 3: This bit is always cleared in the TL16C450 mode. In FIFO mode, this bit is set with bit 2 to indicate that a time-out interrupt is pending.
- Bit 4: Not used (always cleared)
- Bits 5, 6, and 7: These bits are to verify the FIFO operation. When all 3 bits are cleared, TL16C450 mode is chosen. When bits 6 and 7 are set and bit 5 is cleared, 16-byte mode is chosen. When bits 5, 6, and 7 are set, 64-byte mode is chosen.

PRINCIPLES OF OPERATION

interrupt identification register (IIR) (continued)

Table 5. Interrupt Control Functions

INTERRUPT IDENTIFICATION REGISTER				PRIORITY LEVEL	INTERRUPT TYPE	INTERRUPT SOURCE	INTERRUPT RESET METHOD
BIT 3	BIT 2	BIT 1	BIT 0				
0	0	0	1	None	None	None	None
0	1	1	0	1	Receiver line status	Overrun error, parity error, framing error or break interrupt	Reading the line status register
0	1	0	0	2	Received data available	Receiver data available in the TL16C450 mode or trigger level reached in the FIFO mode.	Reading the receiver buffer register
1	1	0	0	2	Character time-out indication	No characters have been removed from or input to the receiver FIFO during the last four character times, and there is at least one character in it during this time	Reading the receiver buffer register
0	0	1	0	3	Transmitter holding register empty	Transmitter holding register empty	Reading the interrupt identification register (if source of interrupt) or writing into the transmitter holding register
0	0	0	0	4	Modem status	Clear to send, data set ready, ring indicator, or data carrier detect	Reading the modem status register

line control register (LCR)

The system programmer controls the format of the asynchronous data communication exchange through the LCR. In addition, the programmer is able to retrieve, inspect, and modify the contents of the LCR; this eliminates the need for separate storage of the line characteristics in system memory. The contents of this register are summarized in Table 3 and described in the following bulleted list.

- Bits 0 and 1: These two bits specify the number of bits in each transmitted or received serial character. These bits are encoded as shown in Table 6.

Table 6. Serial Character Word Length

BIT 1	BIT 0	WORD LENGTH
0	0	5 bits
0	1	6 bits
1	0	7 bits
1	1	8 bits

- Bit 2: This bit specifies either one, one and one-half, or two stop bits in each transmitted character. When bit 2 is cleared, one stop bit is generated in the data. When bit 2 is set, the number of stop bits generated is dependent on the word length selected with bits 0 and 1. The receiver clocks only the first stop bit, regardless of the number of stop bits selected. The number of stop bits generated, in relation to word length and bit 2, is shown in Table 7.

PRINCIPLES OF OPERATION

line control register (LCR) (continued)

Table 7. Number of Stop Bits Generated

BIT 2	WORD LENGTH SELECTED BY BITS 1 AND 2	NUMBER OF STOP BITS GENERATED
0	Any word length	1
1	5 bits	1 1/2
1	6 bits	2
1	7 bits	2
1	8 bits	2

- Bit 3: This bit is the parity enable bit. When bit 3 is set, a parity bit is generated in data transmitted between the last data word bit and the first stop bit. In received data, when bit 3 is set, parity is checked. When bit 3 is cleared, no parity is generated or checked.
- Bit 4: This bit is the even parity select bit. When parity is enabled (bit 3 is set) and bit 4 is set, even parity (an even number of logic 1s in the data and parity bits) is selected. When parity is enabled and bit 4 is cleared, odd parity (an odd number of logic 1s) is selected.
- Bit 5: This is the stick parity bit. When bits 3, 4, and 5 are set, the parity bit is transmitted and checked as cleared. When bits 3 and 5 are set and bit 4 is cleared, the parity bit is transmitted and checked as set. When bit 5 is cleared, stick parity is disabled.
- Bit 6: This bit is the break control bit. Bit 6 is set to force a break condition; i.e., a condition where SOUT is forced to the spacing (low) state. When bit 6 is cleared, the break condition is disabled and has no affect on the transmitter logic; it only affects the serial output.
- Bit 7: This bit is the divisor latch access bit (DLAB). Bit 7 must be set to access the divisor latches of the baud generator during a read or write or access bit 5 of the FCR. Bit 7 must be cleared during a read or write to access the receiver buffer, the THR, or the IER.

line status register (LSR)†

The LSR provides information to the CPU concerning the status of data transfers. The contents of this register are described in the following bulleted list and summarized in Table 3.

- Bit 0: This bit is the data ready (DR) indicator for the receiver. DR is set when a complete incoming character is received and transferred into the RBR or the FIFO. DR is cleared by reading all of the data in the RBR or the FIFO.
- Bit 1‡: This bit is the overrun error (OE) indicator. When OE is set, it indicates that before the character in the RBR was read, it was overwritten by the next character transferred into the register. OE is cleared every time the CPU reads the contents of the LSR. When the FIFO mode data continues to fill the FIFO beyond the trigger level, an OE occurs only after the FIFO is full and the next character has been completely received in the shift register. An OE is indicated to the CPU as soon as it happens. The character in the shift register is overwritten, but it is not transferred to the FIFO.
- Bit 2‡: This bit is the parity error (PE) indicator. When PE is set, it indicates that the parity of the received data character does not match the parity selected in the LCR (bit 4). PE is cleared every time the CPU reads the contents of the LSR. In the FIFO mode, PE is associated with the particular character in the FIFO to which it applies. PE is revealed to the CPU when its associated character is at the top of the FIFO.

† The line status register is intended for read operations only; writing to this register is not recommended outside of a factory testing environment.

‡ Bits 1 through 4 are the error conditions that produce a receiver line status interrupt.



PRINCIPLES OF OPERATION

line status register (LSR)† (continued)

- Bit 3‡: This bit is the framing error (FE) indicator. When FE is set, it indicates that the received character does not have a valid (set) stop bit. FE is cleared every time the CPU reads the contents of the LSR. In the FIFO mode, this error is associated with the particular character in the FIFO to which it applies. FE is revealed to the CPU when its associated character is at the top of the FIFO. The ACE tries to resynchronize after a FE. To accomplish this, it is assumed that the FE is due to the next start bit. The ACE samples this start bit twice and then accepts the input data.
- Bit 4: This bit is the break interrupt (BI) indicator. When BI is set, it indicates that the received data input was held in the low state for longer than a full-word transmission time. A full-word transmission time is defined as the total time to transmit the start, data, parity, and stop bits. BI is cleared every time the CPU reads the contents of the LSR. In the FIFO mode, BI is associated with the particular character in the FIFO to which it applies. BI is revealed to the CPU when its associated character is at the top of the FIFO. When a break occurs, only one 0 character is loaded into the FIFO. The next character transfer is enabled after SIN goes to the marking state for at least two RCLK samples and then receives the next valid start bit.
- Bit 5: This bit is the transmitter holding register empty (THRE) indicator. THRE is set when the THR is empty, indicating that the ACE is ready to accept a new character. If the THRE interrupt is enabled when THRE is set, an interrupt is generated. THRE is set when the contents of the THR are transferred to the TSR. THRE is cleared concurrent with the loading of the THR by the CPU. In the FIFO mode, THRE is set when the transmit FIFO is empty; it is cleared when at least one byte is written to the transmit FIFO.
- Bit 6: This bit is the transmitter empty (TEMT) indicator. TEMT bit is set when the THR and the TSR are both empty. When either the THR or the TSR contains a data character, TEMT is cleared. In the FIFO mode, TEMT is set when the transmitter FIFO and TSR are both empty.
- Bit 7: In TL16C750 mode and in TL16C450 mode, this bit is always cleared. In the FIFO mode, LSR7 is set when there is at least one parity, framing, or break error in the FIFO. It is cleared when the microprocessor reads the LSR and there are no subsequent errors in the FIFO.

modem control register (MCR)

The MCR is an 8-bit register that controls an interface with a modem, data set, or peripheral device that is emulating a modem. The contents of this register are summarized in Table 3 and are described in the following bulleted list.

- Bit 0: This bit (DTR) controls the \overline{DTR} output.
- Bit 1: This bit (RTS) controls \overline{RTS} output.
- Bit 2: This bit (OUT1) controls $\overline{OUT1}$ signal.
- Bit 3: This bit (OUT2) controls the $\overline{OUT2}$ signal.

When any of bits 0 through 3 is set, the associated output is forced low; a cleared bit forces the associated output high.

† The line status register is intended for read operations only; writing to this register is not recommended outside of a factory testing environment.

‡ Bits 1 through 4 are the error conditions that produce a receiver line status interrupt.

PRINCIPLES OF OPERATION

modem control register (MCR) (continued)

- Bit 4: This bit (LOOP) provides a local loop back feature for diagnostic testing of the ACE. When LOOP is set, the following occurs:
 - SOUT is asserted high.
 - SIN is disconnected.
 - The output of the TSR is looped back into the RSR input.
 - The four modem control inputs ($\overline{\text{CTS}}$, $\overline{\text{DSR}}$, $\overline{\text{DCD}}$, and $\overline{\text{RI}}$) are disconnected.
 - The four modem control outputs ($\overline{\text{DTR}}$, $\overline{\text{RTS}}$, $\overline{\text{OUT1}}$, and $\overline{\text{OUT2}}$) are internally connected to the four modem control inputs.
 - The four modem control outputs are forced to their inactive (high) states.
- Bit 5: This bit (AFE) is the autoflow control enable. When bit 5 is set, the autoflow control, as described in the detailed description, is enabled.

In the diagnostic mode, data that is transmitted is immediately received. This allows the processor to verify the transmit and receive data paths to the ACE. The receiver and transmitter interrupts are fully operational. The modem control interrupts are also operational, but the modem control interrupt sources are now the lower four bits of the MCR instead of the four modem control inputs. All interrupts are still controlled by the IER.

The ACE flow can be configured by programming bits 1 and 5 of the MCR as shown in Table 8.

Table 8. ACE Flow Configuration

MCR BIT 5 (AFE)	MCR BIT 1 (RTS)	ACE FLOW CONFIGURATION
1	1	Auto- $\overline{\text{RTS}}$ and auto- $\overline{\text{CTS}}$ enabled (autoflow control enabled)
1	0	Auto- $\overline{\text{CTS}}$ only enabled
0	X	Auto- $\overline{\text{RTS}}$ and auto- $\overline{\text{CTS}}$ disabled

When bit 5 of the FCR is cleared, there is a 16-byte AFC. When bit 5 of the FCR is set, there is a 64-byte AFC.

modem status register (MSR)

The MSR is an 8-bit register that provides information about the current state of the control lines from the modem, data set, or peripheral device to the CPU. Additionally, four bits of this register provide change information. When a control input from the modem changes state, the appropriate bit is set. All four bits are cleared when the CPU reads the MSR. The contents of this register are summarized in Table 3 and are described in the following bulleted list.

- Bit 0: This bit is the change in clear-to-send (ΔCTS) indicator. ΔCTS indicates that $\overline{\text{CTS}}$ has changed states since the last time it was read by the CPU. When ΔCTS is set (autoflow control is not enabled and the modem status interrupt is enabled), a modem status interrupt is generated. When autoflow control is enabled, no interrupt is generated. When ΔCTS is set, sleep or low-power modes are avoided.
- Bit 1: This bit is the change in data set ready (ΔDSR) indicator. ΔDSR indicates that $\overline{\text{DSR}}$ has changed states since the last time it was read by the CPU. When ΔDSR is set and the modem status interrupt is enabled, a modem status interrupt is generated. When ΔDSR is set, the sleep or low-power modes are avoided.

PRINCIPLES OF OPERATION

modem status register (MSR) (continued)

- Bit 2: This bit is the trailing edge of the ring indicator (TERI) detector. TERI indicates that \overline{RI} to the chip has changed from a low to a high level. When TERI is set and the modem status interrupt is enabled, a modem status interrupt is generated. When TERI is set, sleep or low-power modes are avoided.
- Bit 3: This bit is the change in data carrier detect (ΔDCD) indicator. ΔDCD indicates that \overline{DCD} to the chip has changed states since the last time it was read by the CPU. When ΔDCD is set and the modem status interrupt is enabled, a modem status interrupt is generated. When ΔDCD is set, sleep or low-power modes are avoided.
- Bit 4: This bit is the complement of \overline{CTS} . When the ACE is in the diagnostic test mode (LOOP [MCR4] = 1), this bit is equal to the MCR bit 1 (RTS).
- Bit 5: This bit is the complement of \overline{DSR} input. When the ACE is in the diagnostic test mode (LOOP [MCR4] = 1), this bit is equal to the MCR bit 0 (DTR).
- Bit 6: This bit is the complement of \overline{RI} . When the ACE is in the diagnostic test mode (LOOP [MCR4] = 1), this bit is equal to the MCR bit 2 (OUT1).
- Bit 7: This bit is the complement of \overline{DCD} . When the ACE is in the diagnostic test mode (LOOP [MCR4] = 1), this bit is equal to the MCR bit 3 (OUT2).

programmable baud generator

The ACE contains a programmable baud generator that takes a clock input in the range between dc and 16 MHz and divides it by a divisor in the range between 1 and $(2^{16}-1)$. The output frequency of the baud generator is $16\times$ the baud rate. The formula for the divisor is:

$$\text{divisor} = \text{XIN frequency input} \div (\text{desired baud rate} \times 16)$$

Two 8-bit registers, called divisor latches, store the divisor in a 16-bit binary format. These divisor latches must be loaded during initialization of the ACE to ensure desired operation of the baud generator. When either of the divisor latches is loaded, a 16-bit baud counter is also loaded to prevent long counts on initial load.

Tables 9 and 10 illustrate the use of the baud generator with crystal frequencies of 1.8432 MHz and 3.072 MHz respectively. For baud rates of 38.4 kbits/s and below, the error obtained is very small. The accuracy of the selected baud rate is dependent on the selected crystal frequency (see Figure 21).

PRINCIPLES OF OPERATION

programmable baud generator (continued)

Table 9. Baud Rates Using a 1.8432-MHz Crystal

DESIRED BAUD RATE	DIVISOR USED TO GENERATE 16× CLOCK	PERCENT ERROR DIFFERENCE BETWEEN DESIRED AND ACTUAL
50	2304	
75	1536	
110	1047	0.026
134.5	857	0.058
150	768	
300	384	
600	192	
1200	96	
1800	64	
2000	58	0.69
2400	48	
3600	32	
4800	24	
7200	16	
9600	12	
19200	6	
38400	3	
56000	2	2.86

Table 10. Baud Rates Using a 3.072-MHz Crystal

DESIRED BAUD RATE	DIVISOR USED TO GENERATE 16× CLOCK	PERCENT ERROR DIFFERENCE BETWEEN DESIRED AND ACTUAL
50	3840	
75	2560	
110	1745	0.026
134.5	1428	0.034
150	1280	
300	640	
600	320	
1200	160	
1800	107	0.312
2000	96	
2400	80	
3600	53	0.628
4800	40	
7200	27	1.23
9600	20	
19200	10	
38400	5	



PRINCIPLES OF OPERATION

programmable baud generator (continued)

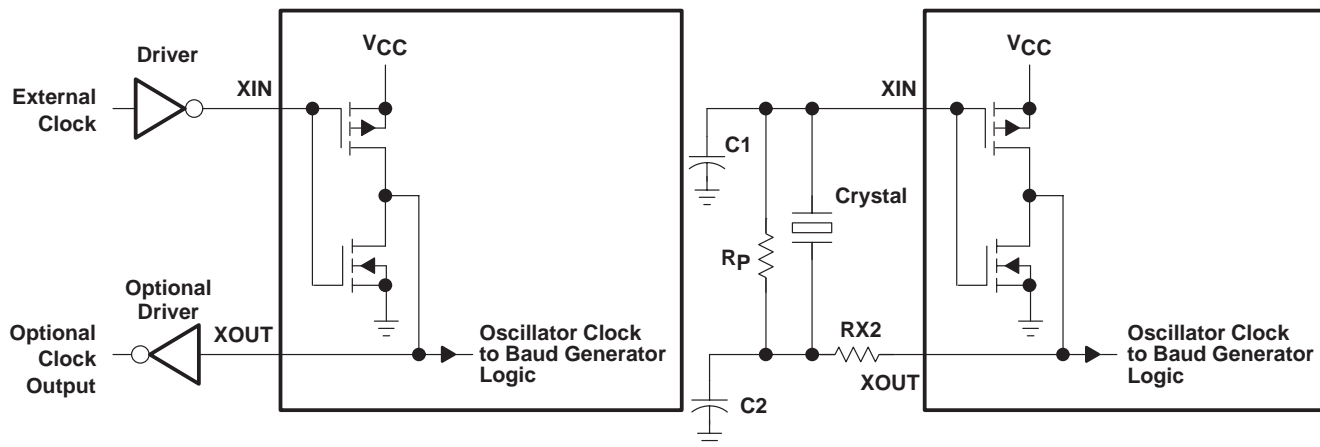

TYPICAL CRYSTAL/OSCILLATOR NETWORK

CRYSTAL	Rp	RX2	C1	C2
3.072 MHz	1 MΩ	1.5 kΩ	10–30 pF	40–60 pF
1.8432 MHz	1 MΩ	1.5 kΩ	10–30 pF	40–60 pF

Figure 21. Typical Clock Circuits

receiver buffer register (RBR)

The ACE receiver section consists of a RSR and a RBR. The RBR is actually a 64-byte FIFO. Timing is supplied by the 16× receiver clock (RCLK). Receiver section control is a function of the ACE line control register.

The ACE RSR receives serial data from the SIN terminal. The RSR then deserializes the data and moves it into the RBR FIFO. In the TL16C450 mode, when a character is placed in the RBR and the received data available interrupt is enabled, an interrupt is generated. This interrupt is cleared when the data is read out of the RBR. In the FIFO mode, the interrupts are generated based on the control setup in the FIFO control register.

scratch register

The scratch register is an 8-bit register used by the programmer as a scratchpad that temporarily holds the programmer data without affecting any other ACE operation.

transmitter holding register (THR)

The ACE transmitter section consists of a THR and a transmitter shift register (TSR). The THR is actually a 64-byte FIFO. Timing is supplied by the baud out (BAUDOUT) clock signal. Transmitter section control is a function of the ACE line control register.

The ACE THR receives data off the internal data bus and when the shift register is idle, moves it into the TSR. The TSR serializes the data and outputs it at the SOUT terminal. In the TL16C450 mode, when the THR is empty and the transmitter holding register empty (THRE) interrupt is enabled (IER1 = 1), an interrupt is generated. This interrupt is cleared when a character is loaded into the register. In the FIFO mode, the interrupts are generated based on the control setup in the FIFO control register.

IMPORTANT NOTICE

Texas Instruments (TI) reserves the right to make changes to its products or to discontinue any semiconductor product or service without notice, and advises its customers to obtain the latest version of relevant information to verify, before placing orders, that the information being relied on is current and complete.

TI warrants performance of its semiconductor products and related software to the specifications applicable at the time of sale in accordance with TI's standard warranty. Testing and other quality control techniques are utilized to the extent TI deems necessary to support this warranty. Specific testing of all parameters of each device is not necessarily performed, except those mandated by government requirements.

Certain applications using semiconductor products may involve potential risks of death, personal injury, or severe property or environmental damage ("Critical Applications").

TI SEMICONDUCTOR PRODUCTS ARE NOT DESIGNED, INTENDED, AUTHORIZED, OR WARRANTED TO BE SUITABLE FOR USE IN LIFE-SUPPORT APPLICATIONS, DEVICES OR SYSTEMS OR OTHER CRITICAL APPLICATIONS.

Inclusion of TI products in such applications is understood to be fully at the risk of the customer. Use of TI products in such applications requires the written approval of an appropriate TI officer. Questions concerning potential risk applications should be directed to TI through a local SC sales office.

In order to minimize risks associated with the customer's applications, adequate design and operating safeguards should be provided by the customer to minimize inherent or procedural hazards.

TI assumes no liability for applications assistance, customer product design, software performance, or infringement of patents or services described herein. Nor does TI warrant or represent that any license, either express or implied, is granted under any patent right, copyright, mask work right, or other intellectual property right of TI covering or relating to any combination, machine, or process in which such semiconductor products or services might be or are used.