



## IQS7221E DATASHEET

ProxFusion® device for on-axis Hall effect angle measurements, including quadrature output, an additional ProxFusion® touch channel, and an on-chip freewheel UI

### 1 Device Overview

The IQS7221E ProxFusion® IC is a sensor fusion device for rotation and angle sensing applications designed for on-axis orientation. A ProxFusion® channel is included for integrated UI applications. Two dedicated Quadrature outputs make the product a drop-in replacement for mechanical and optical rotary encoders. The IQS7221E includes a virtual freewheel UI for more intuitive scrolling.

#### 1.1 Main Features

- > Highly flexible ProxFusion® device
- > Hall effect angle sensor
  - 4 Hall plates
  - Supports on-axis orientation
  - 16-bit absolute angle output
  - < 1° resolution, calculated on-chip
  - Relative/Absolute rotation angle
  - Detect movement and the direction of movement
  - Wide operational range
  - Automatic Tuning Implementation (ATI)
  - Automatic synchronisation with mechanical ratchets
- > ProxFusion® Channel
  - Supports one self-capacitive or mutual-capacitive sensor
  - Ultra-low power wake-up on touch
  - Full auto-tuning (ATI) with adjustable sensitivity
- > Sensor flexibility
  - Internal voltage regulator
  - No external components required for Hall measurements
  - I<sup>2</sup>C Interface with IRQ line
- > Design simplicity and support
  - PC software for debugging and configuring for optimal performance
  - Magnet and mechanical constraints, guidelines and best practices
- > Multiple integrated UIs
  - Proximity and touch events on ProxFusion® channel
  - Proximity wake-up from ultra-low power mode
  - Hysteresis interval mode
  - Event modes with configurable angle-change, interval or touch / prox events
  - Quadrature standalone output for Hall measurements
  - Virtual freewheel UI
- > Supply Voltage 2.2 V to 3.5 V
- > Small packages
  - WLCSP18 (1.62 x 1.62 x 0.5 mm) - interleaved 0.4 mm x 0.6 mm ball pitch
  - QFN20 (3 x 3 x 0.5 mm) - 0.4 mm pitch

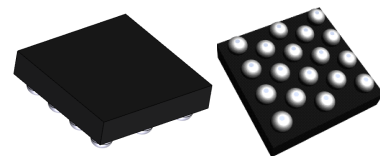

WLCSP18 & QFN20  
package  
Representation only

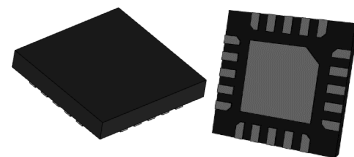



## 1.2 Applications

- > Scroll-wheels for computer peripherals
- > Applications requiring flexible UI options with Sensor Fusion
- > Mechanical and optical rotary encoder replacements
- > Adjustable knobs
- > Motor encoders

## 1.3 Block Diagram

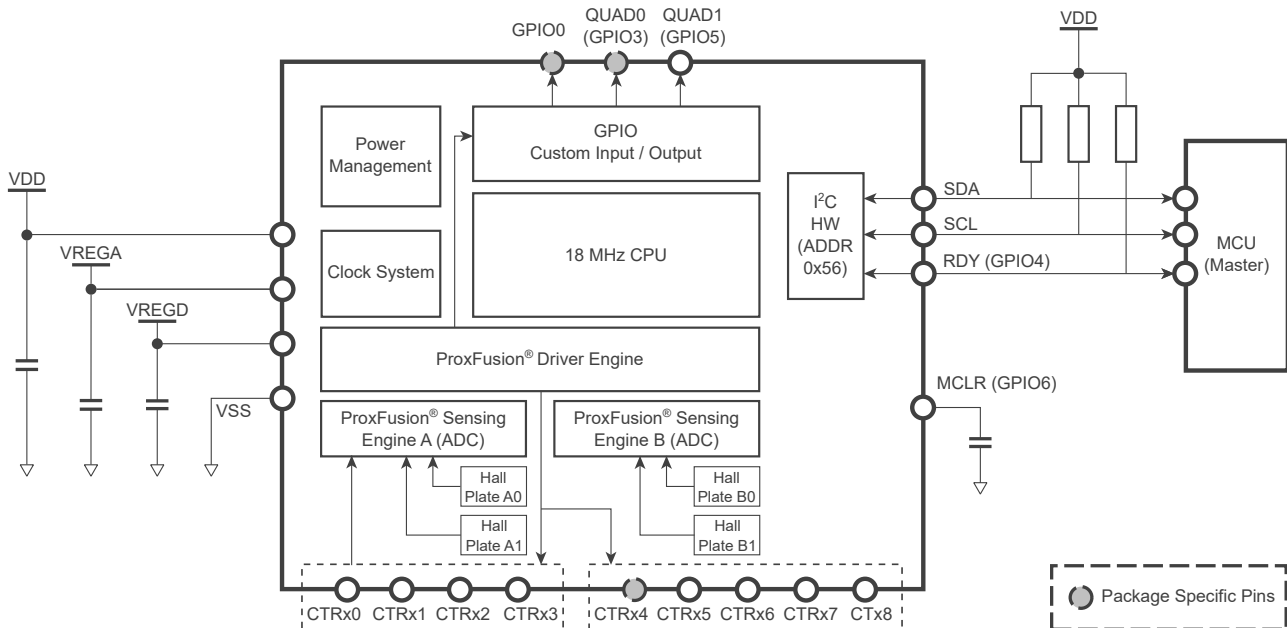

Figure 1.1: Functional Block Diagram<sup>i</sup>

<sup>i</sup>WLCSP18 packages do not have a CRx4 and combines GPIO0 and GPIO3.



## Contents

<b>1</b>	<b>Device Overview</b>	<b>1</b>
1.1	Main Features . . . . .	1
1.2	Applications . . . . .	2
1.3	Block Diagram . . . . .	2
<b>2</b>	<b>Hardware Connection</b>	<b>5</b>
2.1	WLCSP18 Pin Diagrams . . . . .	5
2.2	QFN20 Pin Diagram . . . . .	5
2.3	Pin Attributes . . . . .	6
2.4	Signal Descriptions . . . . .	7
2.5	Reference Schematic . . . . .	8
2.6	Hall Plate Positions . . . . .	9
<b>3</b>	<b>Electrical Characteristics</b>	<b>10</b>
3.1	Absolute Maximum Ratings . . . . .	10
3.2	Recommended Operating Conditions . . . . .	10
3.3	ESD Rating . . . . .	11
3.4	Current Consumption . . . . .	11
<b>4</b>	<b>Timing and Switching Characteristics</b>	<b>12</b>
4.1	Reset Levels . . . . .	12
4.2	MCLR Pin Levels and Characteristics . . . . .	12
4.3	Miscellaneous Timings . . . . .	12
4.4	Digital I/O Characteristics . . . . .	13
4.5	I <sup>2</sup> C Characteristics . . . . .	13
<b>5</b>	<b>ProxFusion<sup>®</sup> Hall Sensor Module</b>	<b>14</b>
5.1	Magnet Orientation . . . . .	14
5.2	Hall Rotation Measurements . . . . .	14
5.3	Hall Rotation Channels . . . . .	15
5.4	Automatic Tuning Implementation (ATI) . . . . .	15
5.5	Runtime ATI . . . . .	15
5.6	Filtering . . . . .	15
5.7	Interval UI . . . . .	15
	5.7.1 Interval Hysteresis . . . . .	16
5.8	High-accuracy Mode . . . . .	16
5.9	Stationary Detection . . . . .	16
5.10	Angle Offset Compensation . . . . .	17
5.11	Interval Centering . . . . .	17
5.12	Quadrature Output . . . . .	18
5.13	Buffered Intervals . . . . .	19
<b>6</b>	<b>ProxFusion<sup>®</sup> Capacitive Sensor Module</b>	<b>20</b>
6.1	Capacitive Channels . . . . .	20
6.2	Count Value . . . . .	20
6.3	Reference Value / Long-Term Average (LTA) . . . . .	20
6.4	Automatic Tuning Implementation (ATI) . . . . .	21
6.5	Automatic Re-ATI . . . . .	21
6.6	Button Events . . . . .	21
6.7	Dormancy . . . . .	21



6.8	Debounce . . . . .	21
6.9	Release UI . . . . .	22
<b>7</b>	<b>Power Options</b>	<b>23</b>
<b>8</b>	<b>Additional Features</b>	<b>25</b>
8.1	Freewheel UI . . . . .	25
8.1.1	Effects of Freewheel Parameters . . . . .	25
8.2	Watchdog Timer (WDT) . . . . .	27
8.3	RF Immunity . . . . .	27
8.4	Reset . . . . .	27
8.4.1	Reset Indication . . . . .	27
8.4.2	Software Reset . . . . .	27
8.5	Version Information . . . . .	27
<b>9</b>	<b>I<sup>2</sup>C Interface</b>	<b>28</b>
9.1	I <sup>2</sup> C Module Specification . . . . .	28
9.2	I <sup>2</sup> C Starting Behaviour . . . . .	28
9.3	I <sup>2</sup> C Address . . . . .	28
9.4	I <sup>3</sup> C Compatibility . . . . .	28
9.5	Memory Map Addressing . . . . .	28
9.6	Data . . . . .	28
9.7	RDY/IRQ . . . . .	29
9.8	I <sup>2</sup> C Timeout . . . . .	29
9.9	Terminate Communication . . . . .	30
9.10	Invalid Communications Return . . . . .	30
9.11	I <sup>2</sup> C Interface . . . . .	30
9.11.1	I <sup>2</sup> C Streaming . . . . .	30
9.11.2	I <sup>2</sup> C Event Mode . . . . .	30
9.12	Event Mode Communication . . . . .	31
9.12.1	Events . . . . .	31
9.12.2	Force Communication . . . . .	31
<b>10</b>	<b>I<sup>2</sup>C Memory Map</b>	<b>32</b>
<b>11</b>	<b>Ordering Information</b>	<b>35</b>
11.1	Ordering Code . . . . .	35
11.2	Top Marking . . . . .	35
11.2.1	WLCSP18 Package Marking Option 1 . . . . .	35
11.2.2	WLCSP18 Package Marking Option 2 . . . . .	35
11.2.3	QFN20 Package Marking Option 1 (IQS7221E001QFR) . . . . .	35
11.2.4	QFN20 Package Marking Option 2 (IQS7221E001QNR) . . . . .	36
<b>12</b>	<b>Package Specification</b>	<b>37</b>
12.1	Package Outline Description – QFN20 (QFR) . . . . .	37
12.2	Package Outline Description – QFN20 (QNR) . . . . .	38
12.3	Package Outline Description – WLCSP18 . . . . .	39
12.4	Tape and Reel Specifications . . . . .	40
12.5	Moisture Sensitivity Levels . . . . .	41
12.6	Reflow Specifications . . . . .	41
<b>A</b>	<b>Memory Map Descriptions</b>	<b>42</b>

## 2 Hardware Connection

### 2.1 WLCSP18 Pin Diagrams

Table 2.1: 18-pin WLCSP18 Package



### 2.2 QFN20 Pin Diagram

Table 2.2: 20-pin QFN Package (Top View)

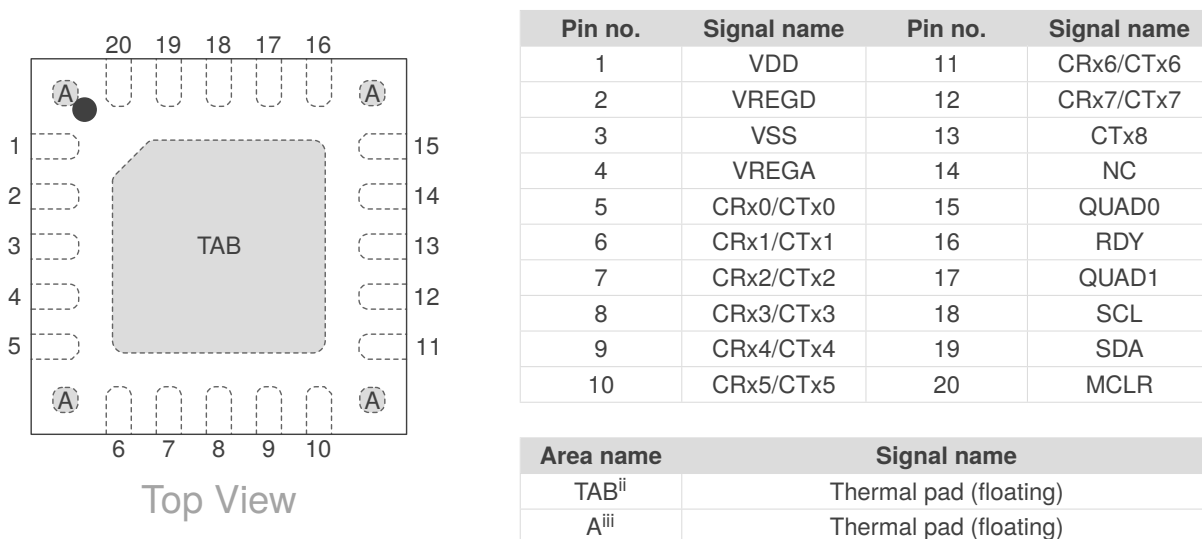

<sup>i</sup> Please note that NC and QUAD0 are connected together in the WLCSP18 package.

<sup>ii</sup> It is recommended to connect the thermal pad (TAB) to VSS.

<sup>iii</sup> Electrically connected to TAB. These exposed pads are only present on *-QNR* order codes.



## 2.3 Pin Attributes

Table 2.3: Pin Attributes

Pin no.		Signal name	Signal type	Buffer type	Power source
WLCSP18	QFN20				
C5	1	VDD	Power	Power	N/A
E5	2	VREGD	Power	Power	N/A
D4	3	VSS	Power	Power	N/A
G5	4	VREGA	Power	Power	N/A
F4	5	CRx0/CTx0	Analog		VREGA
E3	6	CRx1/CTx1	Analog		VREGA
D2	7	CRx2/CTx2	Analog		VREGA
G3	8	CRx3/CTx3	Analog		VREGA
-	9	CRx4/CTx4	Analog		VREGA
F2	10	CRx5/CTx5	Analog		VREGA
E1	11	CRx6/CTx6	Analog		VREGA
G1	12	CRx7/CTx7	Analog		VREGA
C1	13	CTx8	Analog		VREGA
A1	14	NC	Digital		VDD
B4	19	SDA	Digital		VDD
A3	18	SCL	Digital		VDD
A1	15	QUAD0	Digital		VDD
B2	16	RDY	Digital		VDD
C3	17	QUAD1	Digital		VDD
A5	20	MCLR	Digital		VDD



## 2.4 Signal Descriptions

Table 2.4: Signal Descriptions

Function	Signal name	Pin no.		Pin type <sup>iv</sup>	Description
		WLCSP18	QFN20		
ProxFusion®	CRx0/CTx0	F4	5	IO	ProxFusion® channel
	CRx1/CTx1	E3	6	IO	
	CRx2/CTx2	D2	7	IO	
	CRx3/CTx3	G3	8	IO	
	CRx4/CTx4	-	9	IO	
	CRx5/CTx5	F2	10	IO	
	CRx6/CTx6	E1	11	IO	
	CRx7/CTx7	G1	12	IO	
	CTx8	C1	13	O	CTx8 pad
GPIO	NC	A1	14	-	Not Connected
	QUAD0	A1	15	O	Quadrature output pin 0
	RDY	B2	16	O	RDY pad
	QUAD1	C3	17	O	Quadrature output pin 1
	MCLR	A5	20	IO	Active pull-up, 200k resistor to VDD. Pulled low during POR, and MCLR function enabled by default. VPP input for OTP.
I <sup>2</sup> C	SDA	B4	19	IO	I <sup>2</sup> C Data
	SCL	A3	18	IO	I <sup>2</sup> C Clock
Power	VDD	C5	1	P	Power supply input voltage
	VREGD	E5	2	P	Internal regulated supply output for digital domain
	VSS	D4	3	P	Analog/Digital Ground
	VREGA	G5	4	P	Internal regulated supply output for analog domain

<sup>iv</sup> Pin Types: I = Input, O = Output, IO = Input or Output, P = Power.



## 2.5 Reference Schematic

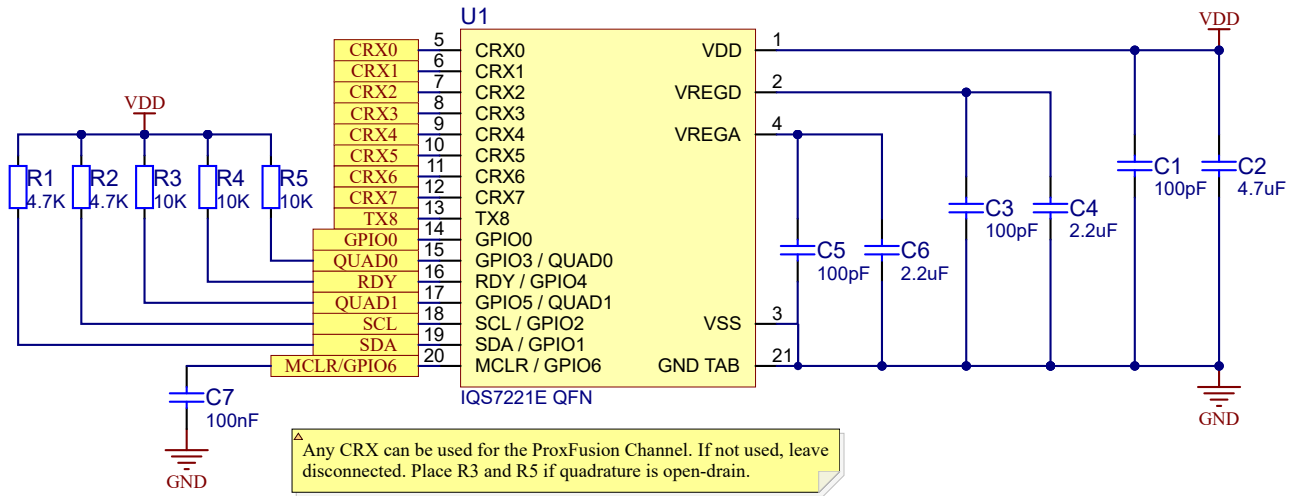

Figure 2.1: IQS7221E QFN Reference Schematic

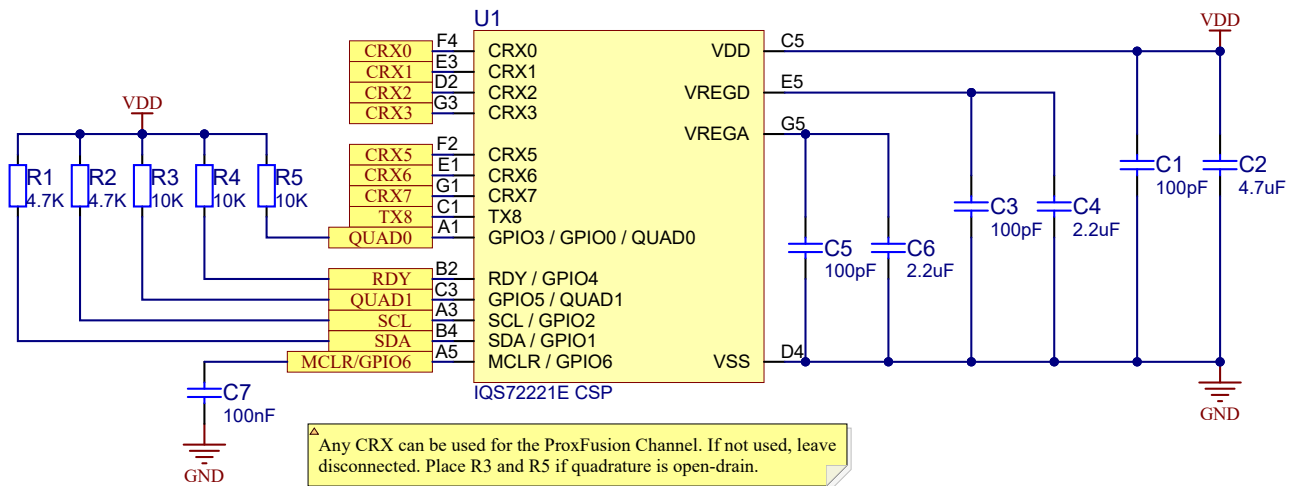

Figure 2.2: IQS7221E CSP Reference Schematic





## 2.6 Hall Plate Positions

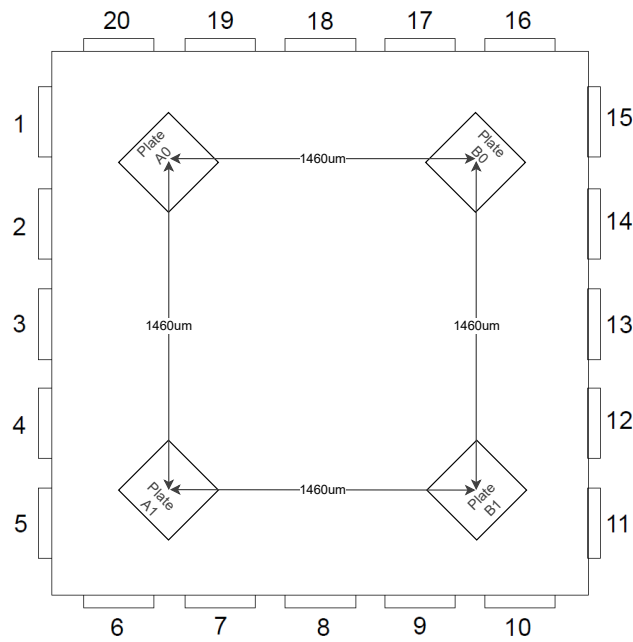

Figure 2.3: Plate Layout QFN (Top View)

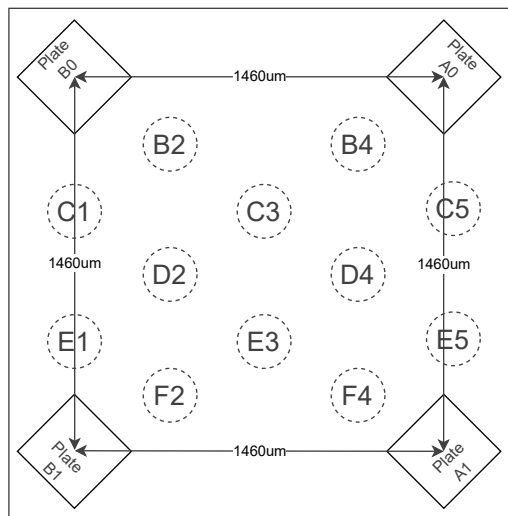

Figure 2.4: Plate Layout WLCSP (Top View)



### 3 Electrical Characteristics

#### 3.1 Absolute Maximum Ratings

Table 3.1: Absolute Maximum Ratings

	Min	Max	Unit
Voltage applied at VDD pin to VSS	2.2	3.5	V
Voltage applied to any ProxFusion® pin	-0.3	VREGA	V
Voltage applied to any other pin (referenced to VSS)	-0.3	VDD + 0.3 (3.5 V max)	V
Storage temperature, T <sub>stg</sub>	-40	85	°C

#### 3.2 Recommended Operating Conditions

Table 3.2: Recommended Operating Conditions

		Min	Nom	Max	Unit
VDD	Supply voltage applied at VDD pin: F <sub>OSC</sub> = 18 MHz	2.2		3.5	V
VREGA	Internal regulated supply output for analog domain: F <sub>OSC</sub> = 18 MHz	1.7	1.75	1.79	V
VREGD	Internal regulated supply output for digital domain: F <sub>OSC</sub> = 18 MHz	1.75	1.8	1.85	V
VSS	Supply voltage applied at VSS pin		0		V
T <sub>A</sub>	Operating free-air temperature	-40	25	85	°C
C <sub>VDD</sub>	Recommended capacitor at VDD	2×C <sub>VREGA</sub>	3×C <sub>VREGA</sub>		μF
C <sub>VREGA</sub>	Recommended external buffer capacitor at VREGA, ESR ≤ 200 mΩ	2	4.7	10	μF
C <sub>VREGD</sub>	Recommended external buffer capacitor at VREGD, ESR ≤ 200 mΩ	2	4.7	10	μF
C <sub>XSELF-VSS</sub>	Maximum capacitance between ground and all external electrodes on all ProxFusion® blocks (self-capacitance mode)	1	-	400 <sup>i</sup>	pF
C <sub>mCTx-CRx</sub>	Capacitance between Receiving and Transmitting electrodes on all ProxFusion® blocks (mutual-capacitance mode)	0.2	-	9 <sup>i</sup>	pF
C <sub>pCRx-VSS-1M</sub>	Maximum capacitance between ground and all external electrodes on all ProxFusion® blocks (mutual-capacitance mode @ f <sub>xfer</sub> = 1 MHz)			100 <sup>i</sup>	pF
C <sub>pCRx-VSS-4M</sub>	Maximum capacitance between ground and all external electrodes on all ProxFusion® blocks (mutual-capacitance mode @ f <sub>xfer</sub> = 4 MHz sensing)			25 <sup>i</sup>	pF
$\frac{C_{pCRx-VSS}}{C_{mCTx-CRx}}$	Capacitance ratio for optimal SNR in mutual-capacitance mode <sup>ii</sup>	10		20	n/a
RC <sub>XCRx/CTx</sub>	Series (in-line) resistance of all mutual-capacitance pins (Tx & Rx pins) in mutual-capacitance mode	0 <sup>iii</sup>	0.47	10 <sup>iv</sup>	kΩ
RC <sub>XSELF</sub>	Series (in-line) resistance of all self-capacitance pins in self-capacitance mode	0 <sup>iii</sup>	0.47	10 <sup>iv</sup>	kΩ



### 3.3 ESD Rating

Table 3.3: ESD Rating

		Value	Unit
V <sub>(ESD)</sub> Electrostatic discharge	Human-body model (HBM), per ANSI/ESDA/JEDEC JS-001 <sup>v</sup>	±4000	V

### 3.4 Current Consumption

Power Mode	Report Rate [ms]	Current Consumption [μA]		
		Hall + Touch	Hall	Touch
High-accuracy	5	1340	1015	640
Normal power	40	205	165	105
Low power	200	45	40	30
Ultra low power <sup>vi</sup>	500	N/A	N/A	10

<sup>i</sup>RC<sub>x</sub> = 0 Ω.

<sup>ii</sup> Please note that the the maximum values for C<sub>p</sub> and C<sub>m</sub> are subject to this ratio.

<sup>iii</sup> Nominal series resistance of 470 Ω is recommended to prevent received and emitted EMI effects. Typical resistance also adds additional ESD protection.

<sup>iv</sup> Series resistance limit is a function of f<sub>xfer</sub> and the circuit time constant, RC.  $R_{max} \times C_{max} = \frac{1}{(6 \times f_{xfer})}$  where C is the pin capacitance to VSS.

<sup>v</sup> JEDEC document JEP155 states that 500-V HBM allows safe manufacturing with a standard ESD control process. Pins listed as ±4000 V may actually have higher performance.

<sup>vi</sup> Only the touch channel is sampled during ULP.

## 4 Timing and Switching Characteristics

### 4.1 Reset Levels

Table 4.1: Reset Levels

Parameter		Min	Typ	Max	Unit
V <sub>VDD</sub>	Power-up/down level (Reset trigger) – slope > 100 V/s	1.040	1.353	1.568	V
V <sub>VREGD</sub>	Power-up/down level (Reset trigger) – slope > 100 V/s	0.945	1.122	1.304	V

### 4.2 MCLR Pin Levels and Characteristics

Table 4.2: MCLR Pin Characteristics

Parameter		Conditions	Min	Typ	Max	Unit
V <sub>IL(MCLR)</sub>	MCLR Input low level voltage	VDD = 3.3 V	VSS – 0.3	-	1.05	V
		VDD = 1.7 V			0.75	
V <sub>IH(MCLR)</sub>	MCLR Input high level voltage	VDD = 3.3 V	2.25	-	VDD + 0.3	V
		VDD = 1.7 V	1.05			
R <sub>PU(MCLR)</sub>	MCLR pull-up equivalent resistor		180	210	240	kΩ
t <sub>PULSE(MCLR)</sub>	MCLR input pulse width – no trigger	VDD = 3.3 V	-	-	15	ns
		VDD = 1.7 V			10	
t <sub>TRIG(MCLR)</sub>	MCLR input pulse width – ensure trigger		250	-	-	ns

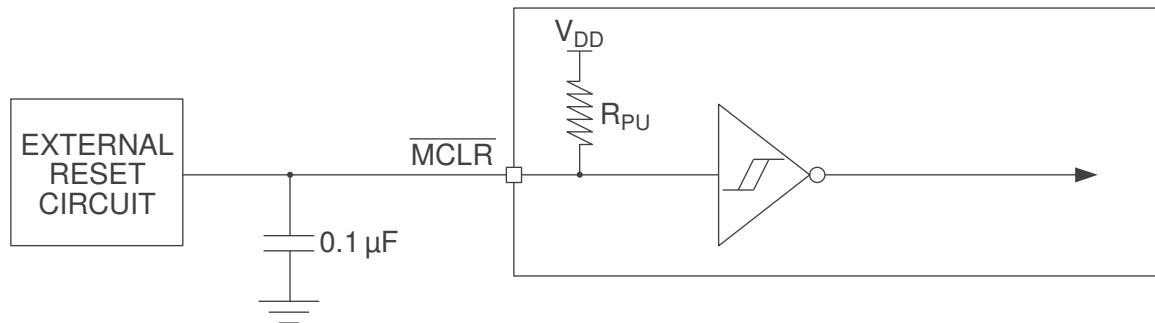

Figure 4.1: MCLR Pin Diagram

### 4.3 Miscellaneous Timings

Table 4.3: Miscellaneous Timings

Parameter		Min	Typ	Max	Unit
f <sub>OSC</sub>	Master CLK frequency tolerance 18 MHz	17.1	18	19.54	MHz
f <sub>xfer</sub>	Charge transfer frequency (derived from f <sub>OSC</sub> )	42	500 – 1500	4500	kHz



## 4.4 Digital I/O Characteristics

Table 4.4: Digital I/O Characteristics

Parameter	Test Conditions	Min	Typ	Max	Unit
V <sub>OL</sub>	SDA & SCL Output low voltage	I <sub>sink</sub> = 20 mA		0.3	V
V <sub>OL</sub>	GPIO <sup>i</sup> Output low voltage	I <sub>sink</sub> = 10 mA		0.15	V
V <sub>OH</sub>	Output high voltage	I <sub>source</sub> = 20 mA	VDD - 0.2		V
V <sub>IL</sub>	Input low voltage			VDD × 0.3	V
V <sub>IH</sub>	Input high voltage		VDD × 0.7		V
C <sub>b_max</sub>	SDA & SCL maximum bus capacitance			550	pF

## 4.5 I<sup>2</sup>C Characteristics

Table 4.5: I<sup>2</sup>C Characteristics

Parameter	VDD	Min	Typ	Max	Unit
f <sub>SCL</sub>	2.2 V, 3.3 V			1000	kHz
t <sub>HD,STA</sub>	2.2 V, 3.3 V	0.26			μs
t <sub>SU,STA</sub>	2.2 V, 3.3 V	0.26			μs
t <sub>HD,DAT</sub>	2.2 V, 3.3 V	0			ns
t <sub>SU,DAT</sub>	2.2 V, 3.3 V	50			ns
t <sub>SU,STO</sub>	2.2 V, 3.3 V	0.26			μs
t <sub>SP</sub>	2.2 V, 3.3 V	0		50	ns

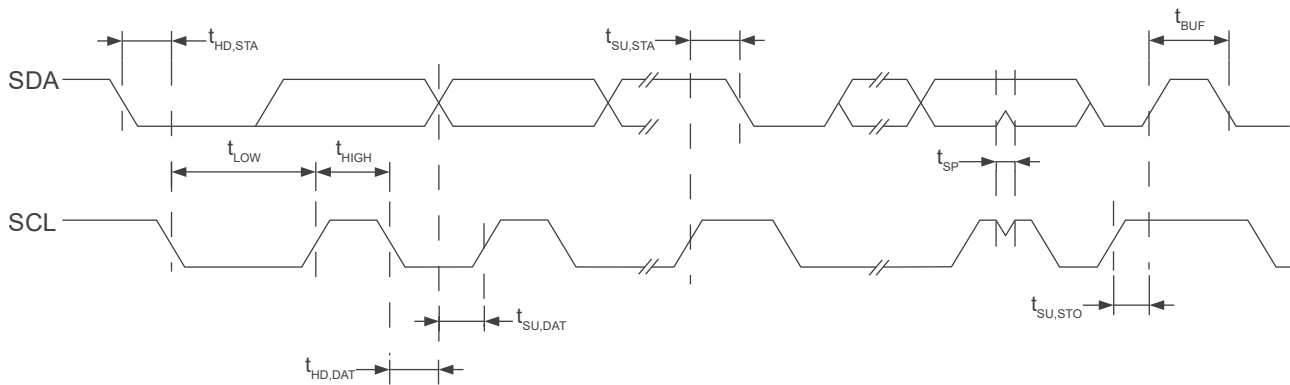

Figure 4.2: I<sup>2</sup>C Mode Timing Diagram

<sup>i</sup> Refers to NC, QUAD0, RDY, and QUAD1 pins.



## 5 ProxFusion® Hall Sensor Module

The IQS7221E contains four equally-spaced Hall plates that measure the magnetic field strength and orientation of a nearby diametrically-polarised magnet. Two ProxFusion® modules allow for simultaneous sampling of two Hall plates at a time, improving the responsiveness of the system. The Hall sensor provides an interval UI to track the current angle of the magnet. The I<sup>2</sup>C interface can be used to track the absolute angle of the magnet. The quadrature outputs provide an interface for relative angle tracking in low-power systems and can act as a drop-in replacement for existing digital rotational encoders.

### 5.1 Magnet Orientation

The IQS7221E is designed to be used in an on-axis orientation with regard to the magnet, as shown in Figure 5.1.

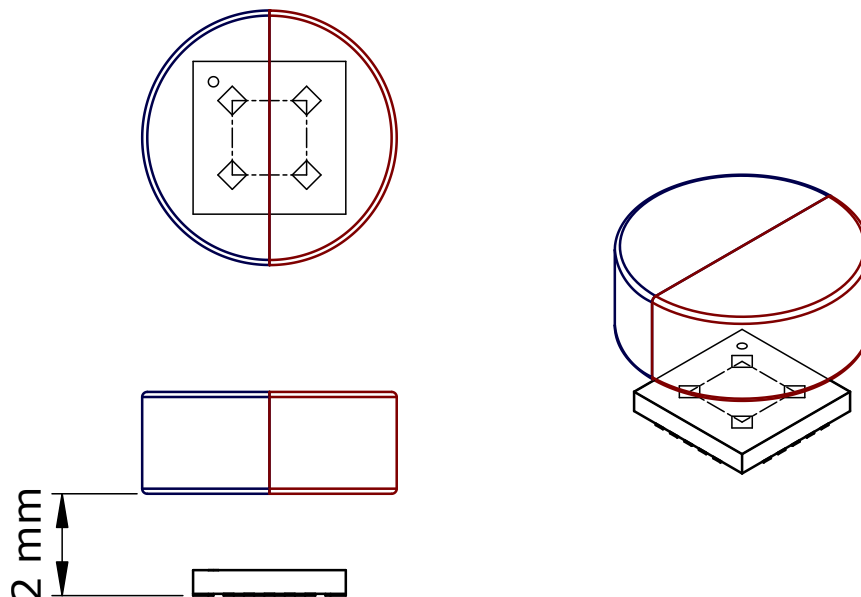

Figure 5.1: Magnet Orientation of an On-axis Angle Measurement Application

### 5.2 Hall Rotation Measurements

The IQS7221E provides the angle measurement as three different values:

- > **Absolute Angle:** Raw angle measurement, provided as an unsigned 16-bit value, where the range [0, 65536) maps to [0°, 360°). This represents the angle of the magnet relative to the IC.
- > **Processed Angle:** Angle measurement after post-processing, also an unsigned 16-bit value. This output is filtered and includes an angular offset. This output is recommended for applications requiring high-resolution measurements.
- > **Interval:** The output of the interval-UI, which divides the unsigned 16-bit processed angle into several sections, or intervals. This output is recommended for applications with mechanical ratchets and is supplemented by the hysteresis, auto-zero, and quadrature features.



### 5.3 Hall Rotation Channels

The Hall effect measurement on the IQS7221E relies on two measurements on each of the four Hall plates, where the second measurement is inverted to the first. These two measurements allow for the calculation of a reference value from which the relative strength of the magnetic field can be inferred. This reference value is calculated as

$$\text{Hall Reference} = \frac{2}{\frac{1}{\text{Counts}} + \frac{1}{\text{Inverted Counts}}} \quad (1)$$

As a result, the IQS7221E has eight Hall effect channels, four of which are inverted to the others. The channel samples are available in the **Hall plate counts** and **Hall reference** registers.

### 5.4 Automatic Tuning Implementation (ATI)

ATI is an automatic sensor calibration algorithm which will configure the **Hall plate settings** to allow for accurate Hall effect sensing on a range of different magnet sizes and strengths. The ATI aims to modify the Hall plate settings such that the Hall channel reference values are within the range defined by the **target minimum** and **target maximum** parameters. The resulting Hall reference will be approximately equal to a target reference value defined as

$$\text{Target Reference} = \frac{2}{\frac{1}{\text{Target Max}} + \frac{1}{\text{Target Min}}} \quad (2)$$

### 5.5 Runtime ATI

ATI is performed at startup as well as when all the following criteria are met:

- > The stationary flag is set, see Section 5.9.
- > The **Hall reference** of a channel is outside the threshold defined by Equation (3).

$$|\text{Target Reference} - \text{Hall Reference}| > \frac{\text{Target Max} - \text{Target Min}}{\text{Band Error Fraction}} \quad (3)$$

- > Runtime ATI is enabled in **Hall UI settings**.

### 5.6 Filtering

High-frequency variations in the angle are filtered out according to the parameters defined under **Hall filter settings**. The IC features a slow filter and a fast filter. The slow filter is active by default. The fast filter is activated when the difference between the outputs of the fast and slow filters exceeds the **filter switch threshold**. This ensures low jitter on the output angle during slow rotations as well as responsiveness to fast rotations.

### 5.7 Interval UI

The interval UI divides the 16-bit processed angle into a value between 0 and **number of intervals**, where the size of each interval is defined as

$$\text{Interval Size} = \frac{2^{16}}{\text{Number of Intervals}} \quad (4)$$



This is especially useful for applications that do not require a high measurement resolution, or that use mechanical ratchets.

The interval UI is also used for the quadrature UI. On interval change, the IQS7221E will output a quadrature event on the quadrature pins. The device can also open an I<sup>2</sup>C communications window on interval change if the device if **I<sup>2</sup>C streaming** is enabled.

### 5.7.1 Interval Hysteresis

The interval hysteresis prevents the interval output from jittering between two intervals, causing unnecessary interval-change events. The behaviour of the hysteresis is shown in Figure 5.2.

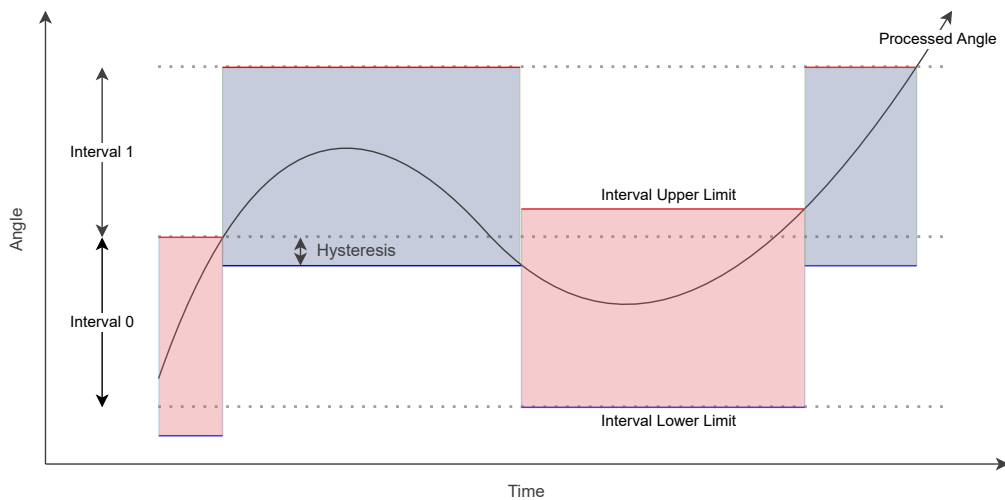

Figure 5.2: Illustration of the Interval Size and Interval Hysteresis

The amount of hysteresis applied can be modified by changing the **interval hysteresis** value.

## 5.8 High-accuracy Mode

The high-accuracy mode of the IQS7221E will increase the report rate of the device to sample Hall rotation measurements more accurately, and to reduce aliasing during high rotation rates.

The IQS7221E will enter high-accuracy mode in the event of:

- > An interval change
- > Freewheeling when the “force high-accuracy” bit is set under the **Hall UI settings** register.
- > The difference between fast and slow filtered values exceeds the **filter switch threshold**.

The **high-accuracy** flag will remain set for the duration of the **high-accuracy timeout**. This flag is used to identify whether to go into high-accuracy mode, and can be configured to signal an automatic interval centering event when high-accuracy mode is exited.

## 5.9 Stationary Detection

The IQS7221E will set a stationary flag if no movement is detected during the period defined by the **stationary timeout** value. This stationary flag is used to identify whether to go into a lower power mode, and can be configured to signal an automatic interval centering event. Runtime ATI for the Hall channels is also only executed when stationary.



## 5.10 Angle Offset Compensation

**Angle offset compensation** is applied to ensure the output angle corresponds to the angle of the wheel and not the angle of the magnet. This is especially important for ratchet applications where intervals output by the IC are required to correspond to the mechanically-defined intervals of the wheel.

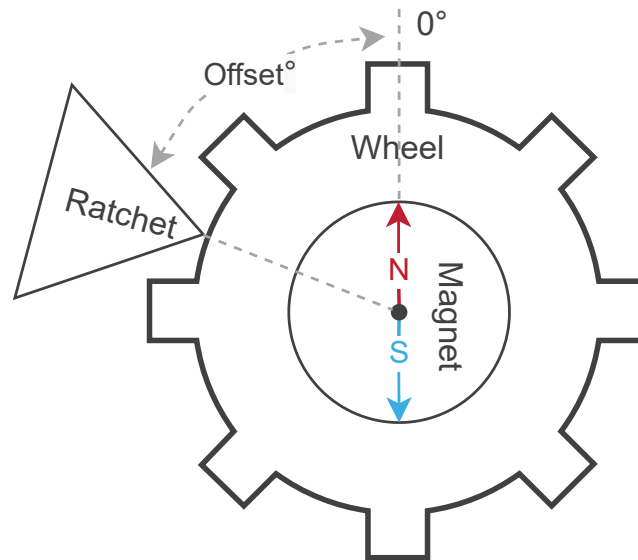

Figure 5.3: Illustration of the Absolute Angle Offset

Three forms of offset compensation can be applied:

- > Manual Offset Compensation
- > Startup Offset Compensation
- > Automatic Offset Compensation

## 5.11 Interval Centering

The interval centering functionality of the IQS7221E allows the device to modify the absolute angle offset of the final angle such that the final angle is at the center of the current interval. This is very useful for configuring the absolute angle offset to align with the physical intervals of a ratchet device.

The device can be configured to automatically trigger an interval centering action. Alternatively, the *zero now* bit can be set in the **Hall UI settings** to set the absolute angle offset such that the **processed angle** is at the center of the first interval.

The auto-zero mode can be set in the **Hall UI settings** to four different settings:

- > **Off**: The device will never allow an automatic interval zero action to happen and the master device will have to send an instruction over I<sup>2</sup>C to set the *zero now* bit.
- > **Stationary**: An auto-zero event will occur when the high-accuracy timeout event occurs. A single adjustment is made to the absolute angle offset each time the device exits high-accuracy mode. The **auto-zero beta** parameter defines the size of the adjustment, with an auto-zero beta value of 0 resulting in a jump to the exact center of the interval. This behaviour can be viewed in Figure 5.4.
- > **Continuous**: The auto-zero filter will always be active and will cause the final angle to continu-



ously move towards the center of the current interval. It is recommended to use a high **auto-zero beta** value to allow the final angle to move between intervals during slower rotations. This mode applies to devices without a mechanical ratchet, or with haptic ratchet effects. This behaviour can be viewed in Figure 5.5

- > **Release:** An auto-zero event will occur when the touch release event occurs in addition to the criterion for the stationary auto-zero mode.

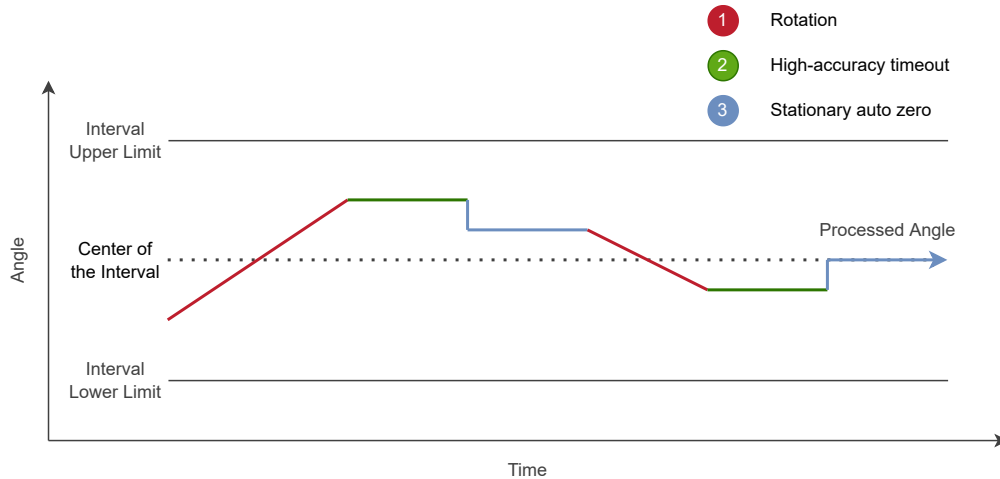

Figure 5.4: Stationary Auto-zero Behaviour

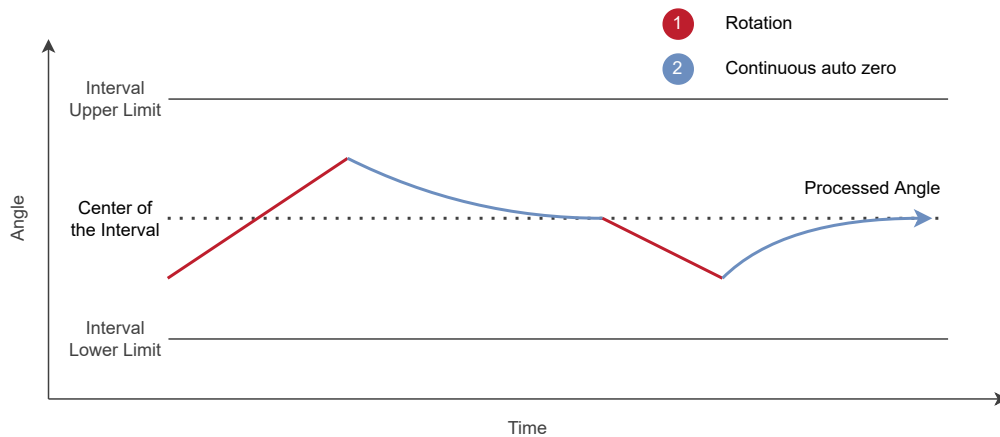

Figure 5.5: Continuous Auto-zero Behaviour

## 5.12 Quadrature Output

The quadrature output provides feedback over two GPIOs (QUAD0 and QUAD1) when the value of the current interval changes. This functionality can be used for standalone applications where the master device would not need to poll the current interval value over I<sup>2</sup>C but would rather monitor the state of the two quadrature outputs. A visual example of the quadrature output is displayed in Figure 5.6.

A single interval change is represented by a rising or falling edge on both quadrature pins. The direction of the interval change is defined by which pin changes state first. For a positive rotation, the state of QUAD0 changes first, and for a negative rotation, the state of QUAD1 changes first. The period between the change in states of each quadrature output is defined by the **quadrature flank delay** parameter. The quadrature flank delay parameter will also define the maximum report rate of the quadrature output.



The quadrature output pins can be configured as either push-pull or open-drain by setting the **quadrature mode** parameter. If open-drain mode is used, pull-up resistors must be added to the quadrature lines as shown in the reference schematic in Section 2.5.

**Note:** The quadrature output can be fed directly into a standard quadrature decoder. Please note that, since some quadrature decoders expect only one GPIO edge per interval (instead of two), they will record twice the number of intervals.

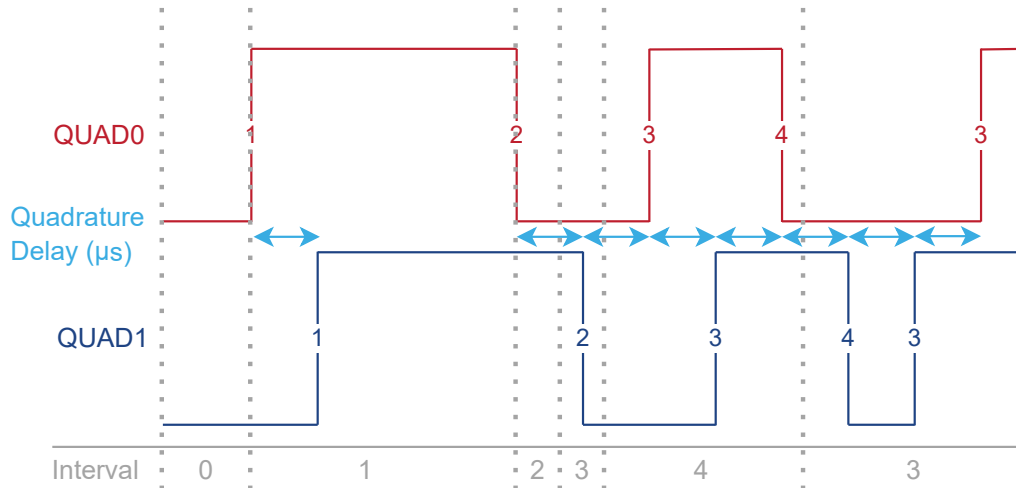

Figure 5.6: Quadrature IO Timing with Respect to Current Interval

Note the rapid change from interval 2 to 4 in Figure 5.6 resulting in a delayed output of the corresponding flanks, so as not to overwhelm the receiving IC.

### 5.13 Buffered Intervals

During fast rotation, the rate at which intervals are processed may exceed the rate at which quadrature pulses are clocked out. These intervals are buffered in the missed intervals register, and are processed by the quadrature output peripheral at a later time. The buffered intervals can automatically be discarded when the device becomes stationary by setting the discard intervals bit in the **Hall UI settings** register.



## 6 ProxFusion® Capacitive Sensor Module

The IQS7221E contains a single capacitive sensing channel that uses the patented technology on one of the two ProxFusion® modules on the device to measure and process capacitive sensor data.

### 6.1 Capacitive Channels

Mutual-capacitive and self-capacitive designs are possible with the IQS7221E.

- > Self-capacitive sensor pad design overview: [AZD008](#)
- > Mutual-capacitive (also known as Projected capacitance) button layout guide: [AZD036](#)

### 6.2 Count Value

Capacitive sensing measurements return **counts values** for the single channel of the device. Count values are inversely proportional to the measured capacitance, and all outputs are derived from this value.

The counts measured are limited to a range defined by the **maximum counts** parameter. If a result outside the range is measured, the maximum value will be returned.

The **raw count values** sampled are filtered with multiple beta filters to produce **filtered count values** and **long-term average count values**. The **button beta** parameters define the beta values for calculating the filtered count values in normal and low power modes.

### 6.3 Reference Value / Long-Term Average (LTA)

User interaction is detected by comparing the measured count values to a reference value. The reference value of a channel is slowly updated to track changes in the environment and is not updated during user interaction.

The signed **delta value** stores the difference between the filtered counts and the reference channel. This value is used to detect user interaction and will cause button events if it exceeds the thresholds defined by the **proximity** and **touch** threshold parameters.

The filter used to calculate the long-term average signal of the channel is defined by the **button LTA beta** and **button fast LTA beta** parameters. The device will select an appropriate beta filter depending on the current power mode and the delta value of the channel. If the delta value is greater than the **fast bound** parameter in the opposite direction of a delta caused by touch, the LTA will be calculated using the fast LTA beta filter.

The reference value of a channel needs to accurately define the environment of the device to detect a user interaction and requires a method of re-evaluating the environment if an invalid state is entered. The reseed function of the device will replace the long-term average value of the channel with the latest sampled counts value to reset the environmental reference of the channel. A **reseed** command can be given by setting the corresponding bit.



## 6.4 Automatic Tuning Implementation (ATI)

The ATI is a sophisticated technology implemented in ProxFusion® devices to allow optimal performance of the devices for a wide range of sensing electrode capacitances, without modification to external components. The ATI settings allow tuning of various parameters. For a detailed description of ATI, please contact Azoteq.

The ATI for touch channels functions by using the **base** and **target** parameters to calculate appropriate **multiplier** and **compensation** values to achieve an LTA equal to the ATI target value.

## 6.5 Automatic Re-ATI

One of the most important features of the Re-ATI functionality of the IQS7221E is that it allows easy and fast recovery from an incorrect ATI, such as when performing ATI during user interaction with the sensor. It is recommended to always have the automatic Re-ATI functionality enabled. When a Re-ATI is performed on the IQS7221E, a status bit will be set momentarily to indicate that this has occurred.

An automatic Re-ATI operation is performed when the reference of a channel drifts outside of the acceptable range around the ATI Target, which is defined by the **ATI band fraction** parameter. The boundary for the reference to drift is defined in Equation (5).

$$\text{Re-ATI Boundary} = \text{ATI Target} \times \frac{\text{ATI Band Fraction}}{128} \quad (5)$$

For example, if the ATI Target is selected as 1000 counts and the ATI Band Fraction is selected as 20, an ATI event would be activated if the reference drifted to a value greater than 1158 or less than 842.

## 6.6 Button Events

All button events can be observed by reading the **touch event states** register at I<sup>2</sup>C address *0x13*.

Touch and proximity events are triggered when the channel **delta** exceeds the thresholds configured in the **proximity** and **touch** threshold parameters. The sign of the delta will determine the value of the direction flag under **touch event states**. An example of the touch channel's filtered, LTA, and delta response for an LTA beta of 4, and with the release UI enabled, is displayed in Figure 6.1 and Figure 6.2.

**Note:** Figure 6.1 and Figure 6.2 only displays the behaviour of the device with the release UI enabled.

## 6.7 Dormancy

The touch dormancy flag will be set if the dormancy timeout event occurs after no touch input is received for the period defined in the **dormancy timeout** parameter.

## 6.8 Debounce

The debounce flag will be set if the counts have exceeded the proximity threshold, but have not yet exceeded the touch threshold. The debounce event will continue until a set number of cycles have passed, after which the proximity flag will be set. The debounce timeout will be bypassed if the counts exceed the touch threshold. The device will enter high-accuracy mode when the debounce flag is set.

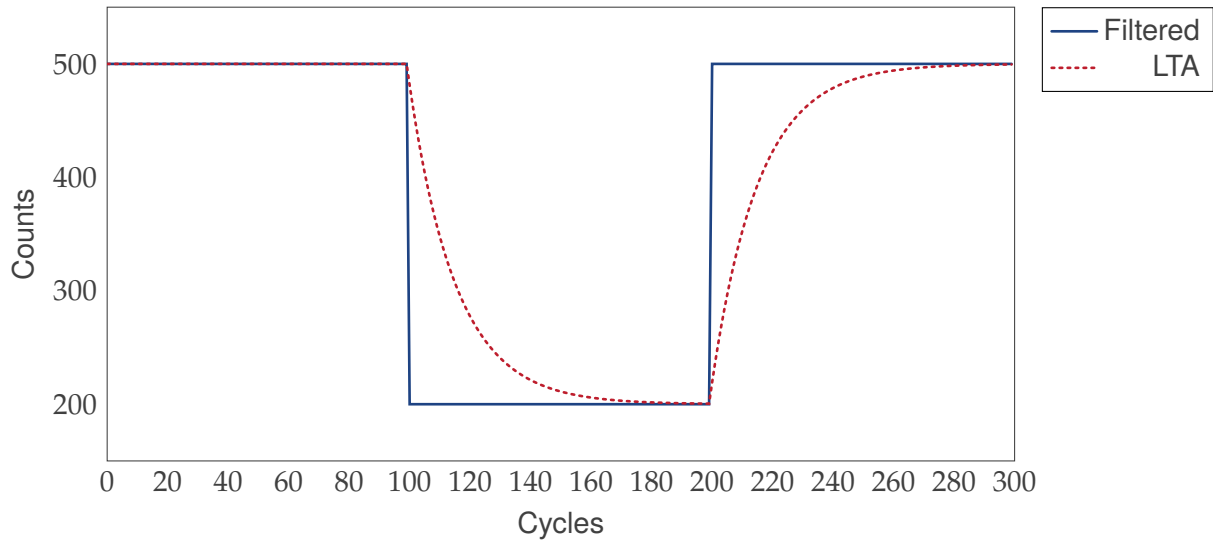

Figure 6.1: Channel Filtered Counts and LTA Response during a Touch Event, with the Release UI Enabled

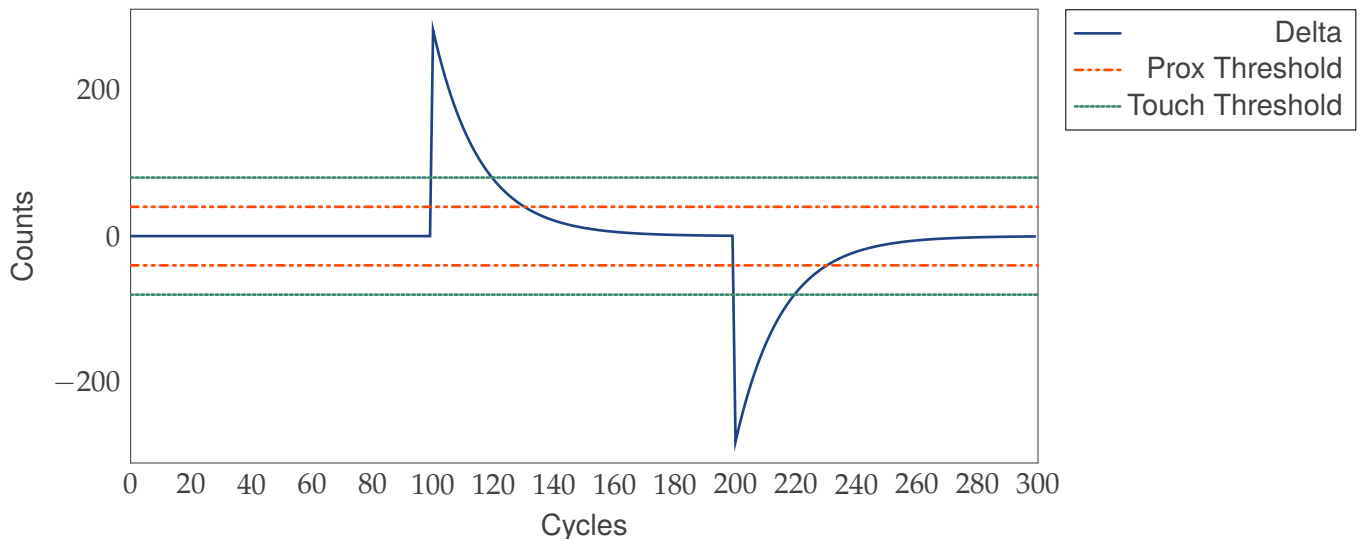

Figure 6.2: Channel Delta Response during a Touch Event

## 6.9 Release UI

The button UI of the device can sense both touch and release user interactions. The **release UI** bit will determine the behaviour of the reference channel during touch. If the bit is set the device will continue to update the reference channel of the device during a touch event. This will result in a positive touch delta when a touch event occurs and will result in a negative touch delta if a release event occurs. This can be viewed in Figure 6.2.

If the **release UI** bit is cleared the device will not update the reference channel of the device during a touch event. This will cause the touch delta to remain high during the touch event. The touch delta will then return to zero as the touch is released.

The **dual threshold** bit must be set for both negative and positive touch deltas to trigger a touch event.



## 7 Power Options

The IQS7221E offers 5 power modes:

- > High-accuracy (HA)
  - Highest current consumption
  - Must always be configured to have the fastest report rate
  - High-accuracy mode is always entered during:
    - \* ATI event
    - \* Touch debounce
  - When in automatic power mode, high-accuracy mode is entered when:
    - \* The rotation sampled by the Hall effect sensor is fast enough for the **filter switch delta** threshold to be surpassed.
    - \* The **interval** value has changed.
    - \* A freewheeling event occurs with the **force high-accuracy** option enabled.
- > Normal power mode (NP)
  - The default operating power mode
  - When in automatic power mode, normal power mode is entered when:
    - \* Exiting high-accuracy mode after the high-accuracy timeout
    - \* Touch event
    - \* Prox event
- > Low power mode (LP)
  - Lower current consumption than normal power
  - Must be configured to have a slower report rate than normal power
  - When in automatic power mode, low power mode is entered when:
    - \* Hall stationary timeout event occurs
    - \* Touch dormancy timeout event occurs
- > Ultra-low power mode (ULP)
  - Recommended being configured for the slowest report rate.
  - The sampling rate of the device in ULP is defined by the ULP report rate, but the **auto prox cycles** will define the number of samples before an I<sup>2</sup>C communication window is opened.
  - ULP mode will only sample the single touch channel of the device. The device will exit ULP mode if a touch event occurs. ULP must not be enabled if the touch functionality of the device is disabled.
  - The device will only enter ULP if the *ULP enable* bit is set in the **system settings** register.
  - Hall channels will not be sampled when the device is in ULP mode.
  - The device will not enter ULP if there are missed intervals that need to be processed.
  - The device will enter ULP mode if the **ULP timeout event** occurs. The ULP timer is started when the device enters LP mode.
- > Halt power mode
  - Is entered and exited by an I<sup>2</sup>C command
  - Places device in I<sup>2</sup>C standby mode
  - No analog sampling events occur during halt mode
  - Entering halt mode safely requires the manual configuration of a **WDT timeout** of more than 4000 ms.
  - To exit halt mode the master device must open a forced communications window and select an alternative power mode for the IQS7221E.







## 8 Additional Features

### 8.1 Freewheel UI

The freewheeling UI of the IQS7221E allows the device to continue emulating rotational input when no physical rotation is detected by the Hall effect sensor. The freewheeling functionality of the device will continue to update the final angle and the current interval of the device at the rotational speed which was sampled from the Hall effect sensor during physical rotation. This speed will eventually decay until the freewheeling event has ended and no emulated response is produced. This feature of the device is targeted at mouse scroll-wheel applications.

A freewheeling event can occur when the freewheeling UI is enabled and a touch release event occurs when the rotational speed of the physical input is greater than the **freewheeling start speed**. Freewheeling continues until the freewheeling speed decays below the value defined in the **freewheeling stop speed** parameter.

The touch release delta required to start a freewheeling event is defined by the **forward release** and **reverse release** parameters. These parameters are used to set different touch release sensitivity values for freewheeling in different directions.

Freewheeling can manually be stopped during the emulated rotation by triggering a touch event. The **freewheeling touch stop** parameter will determine the touch delta required to stop freewheeling.

#### 8.1.1 Effects of Freewheel Parameters

A simplified equation of the effect of freewheeling on the angular velocity is displayed in Equation (6).

$$\omega_{n+1} = \omega_n - \frac{\text{Friction} + (\text{Damping} \times \omega_n)}{\text{Inertia}} \quad (6)$$

Figure 8.1 displays the change in angular velocity as the freewheeling friction parameter changes. Freewheeling damping remains constant with a value of 5000 and freewheeling inertia remains constant at 150.

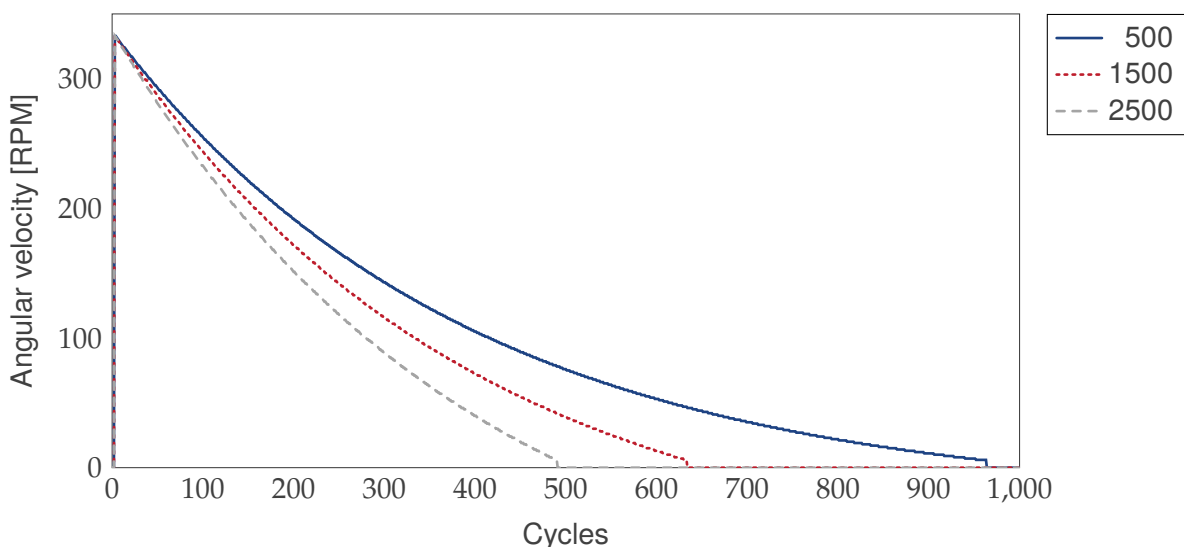

Figure 8.1: Freewheel Response as Friction Changes



Figure 8.2 displays the change in angular velocity as the freewheeling damping parameter changes. Freewheeling friction remains constant with a value of 1000 and freewheeling inertia remains constant at 150.

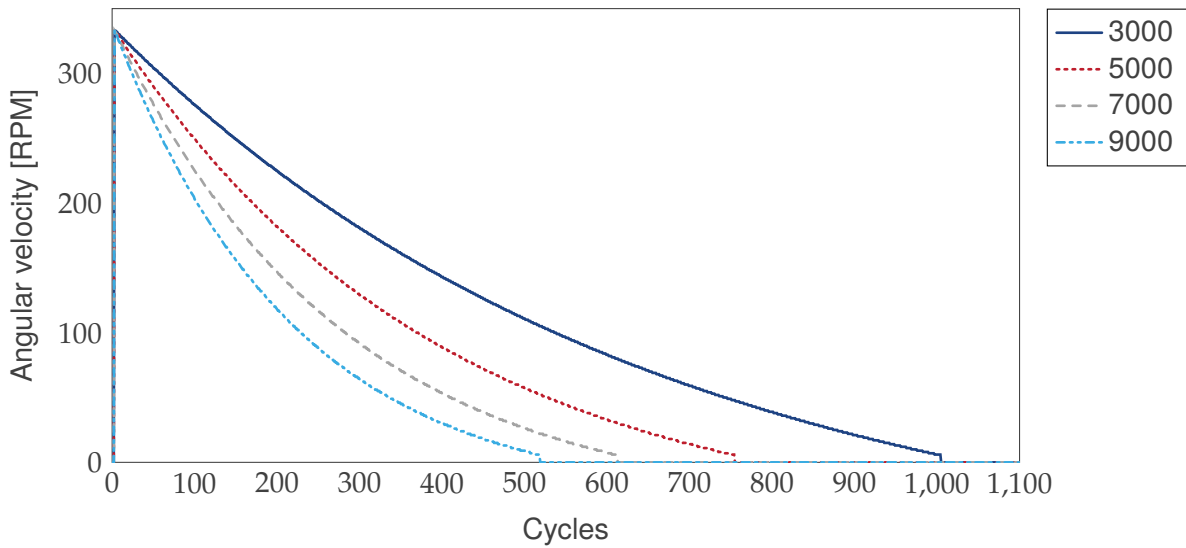

Figure 8.2: Freewheel Response as Damping Changes

Figure 8.3 displays the change in angular velocity as the freewheeling friction parameter changes. Freewheeling damping remains constant with a value of 5000 and freewheeling inertia remains constant at 1000.

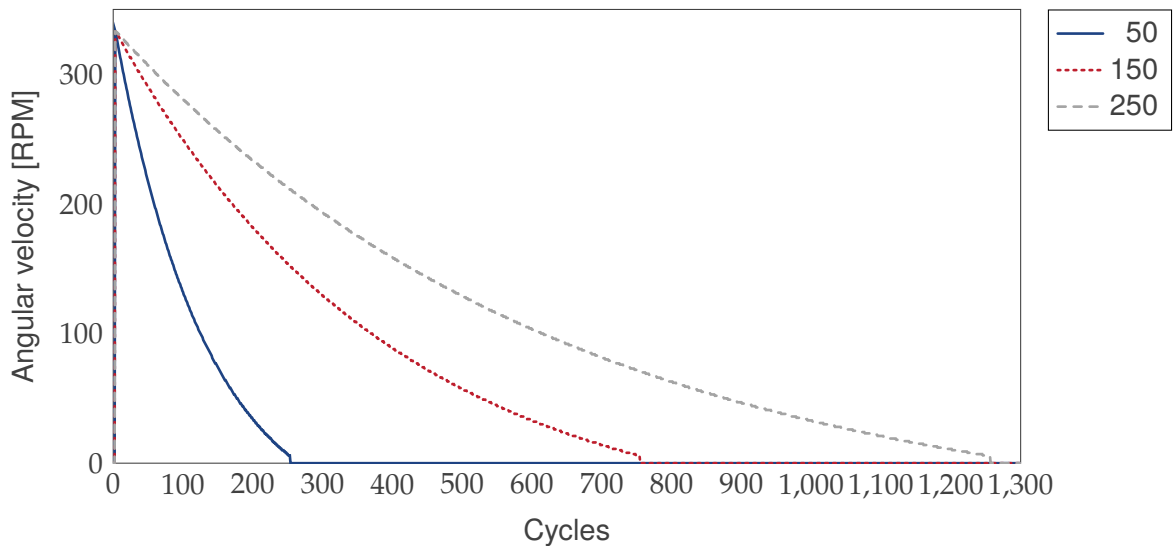

Figure 8.3: Freewheeling Response as Inertia Changes



## 8.2 Watchdog Timer (WDT)

A software watchdog timer is implemented to improve system reliability.

The working of this timer is as follows:

- > This timer is reset at a strategic point in the main loop.
- > Failing to reset this timer will cause the appropriate ISR (interrupt service routine) to run.
- > This ISR performs a software triggered POR (Power on Reset).
- > The device will reset, performing a full cold boot.
- > The **watchdog timeout** register determines the period in milliseconds before the device will reset.
- > Ensure that the watchdog timeout period is greater than the I<sup>2</sup>C timeout period.

## 8.3 RF Immunity

The IQS7221E has immunity to high power RF noise. To improve the RF immunity, extra decoupling capacitors are suggested on  $V_{REG}$  and  $V_{DD}$ .

Place a 100 pF in parallel with the 2.2  $\mu$ F ceramic on  $V_{REG}$ . Place a 4.7  $\mu$ F ceramic on  $V_{DD}$ . All decoupling capacitors should be placed as close as possible to the  $V_{DD}$  and  $V_{REG}$  pads.

If needed, series resistors can be added to Rx electrodes to reduce RF coupling into the sending pads. Normally these are in the range of 470  $\Omega$  - 1 k $\Omega$ . PCB ground planes also improve noise immunity.

## 8.4 Reset

### 8.4.1 Reset Indication

After a reset, the **device reset** bit will be set by the system to indicate the reset event occurred. This device reset bit will clear when the master sets the **ack reset** bit. If the device reset bit becomes set again, the master will know a reset has occurred and can react appropriately.

### 8.4.2 Software Reset

The IQS7221E can be reset by means of an I<sup>2</sup>C command. The **soft reset** bit in the **system settings** register must be set for the device to reset.

## 8.5 Version Information

Please refer to the **version information table**.



## 9 I<sup>2</sup>C Interface

### 9.1 I<sup>2</sup>C Module Specification

The device supports a standard two-wire I<sup>2</sup>C interface with the addition of a RDY (ready interrupt) line. The communications interface of the IQS7221E supports the following:

- > *Fast-mode-plus* standard I<sup>2</sup>C up to 1 MHz.
- > Streaming data as well as event mode (Section 9.11).
- > Interrupt line (RDY), an open-drain active low GPIO indicates a communication window (Section 9.7).

The IQS7221E implements 8-bit addressing with 2 data bytes at each address. Two consecutive read/writes are required in this memory map structure. The two bytes at each address will be referred to as “byte 0” (least significant byte) and “byte 1” (most significant byte).

### 9.2 I<sup>2</sup>C Starting Behaviour

The device will default to streaming mode when the **device reset** bit is set. For the device to communicate as defined in the system settings, the acknowledge reset bit needs to be set.

### 9.3 I<sup>2</sup>C Address

The default 7-bit device address is 0x56 (0b1010110). The full address byte will thus be 0xAD (read) or 0xAC (write).

Other address options exist on special request. Please contact Azoteq.

### 9.4 I<sup>3</sup>C Compatibility

This device is not compatible with an I<sup>3</sup>C bus due to clock stretching allowed for data retrieval.

### 9.5 Memory Map Addressing

The memory map implements an 8-bit addressing scheme for the required user data.

### 9.6 Data

The data is stored in 16-bit words, meaning that each address contains two bytes of data. For example, address 0x10 will provide two bytes, then the next two bytes read will be from address 0x11. The 16-bit data is sent in little endian byte order (least significant byte first).

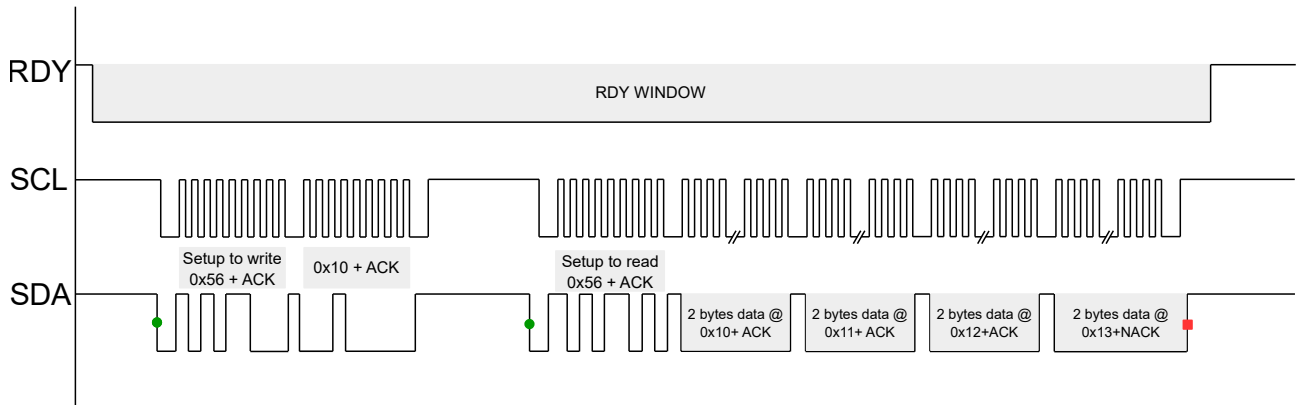

Figure 9.1: Example of Reading Data over I<sup>2</sup>C

The .h file generated by the GUI will display the start address of each block of data, with each address containing 2 bytes. The data of all the addresses can be written consecutively in a single block of data, as shown in Figure 9.1. An example of the h file exported by the GUI and the order of the data, is shown below.

```

/* Change the Global Device Settings */
/* Memory Map Position 0x60 - 0x6F */ // Shows starting address
#define UI_SETTINGS 0x11 // LSB
#define UI_SETTINGS_1 0x09 // MSB
...

```

## 9.7 RDY/IRQ

The IQS7221E has an open-drain active low RDY signal to inform the master that updated data is available. The IQS7221E will pull the RDY line low to indicate that it has opened a communications window, or “RDY window”, for the master to read the new updated data. Once the I<sup>2</sup>C transactions have completed, and an I<sup>2</sup>C stop condition is detected, the RDY line is released and the comms window is closed. The IQS7221E will then go to sleep or continue with a new sensing cycle.

I<sup>2</sup>C communication can only be performed while the RDY window is open. The IC will respond with an error code (0xEE) if communication is attempted while RDY is high. The master can however request a new RDY window using the **Force Communication** method, if necessary.

It is optimal for the master to use this RDY as an interrupt input and obtain the data accordingly. It is also useful to allow the master MCU to enter low power or sleep mode, allowing the IQS7221E’s RDY interrupt to wake the device when user presence is detected. The RDY pin should ideally be connected to an interrupt-on-pin-change input on the master.

Enabling **Event Mode** will set the RDY pin to trigger only when any significant events occur, such as touch events or interval changes. The device can also be placed in **Standalone Mode**, disabling all RDY notifications. Only the quadrature outputs will be enabled.

## 9.8 I<sup>2</sup>C Timeout

If a communication window is not serviced within the **I<sup>2</sup>C Transaction Timeout** period, the session is ended (RDY goes HIGH), and processing continues as normal. This allows the system to continue



and keep reference values up to date even if the master is not responsive. However, the corresponding data will be lost, so this should be avoided. The default I<sup>2</sup>C timeout period is set to 500 ms.

## 9.9 Terminate Communication

A standard I<sup>2</sup>C STOP ends the current communication window.

If the **Stop Ends Comms Disable** bit is set, the device will not close the communication window on a standard I<sup>2</sup>C STOP. Instead, the communication window must be terminated using the end communications command (0xFF), as shown in Figure 9.2.

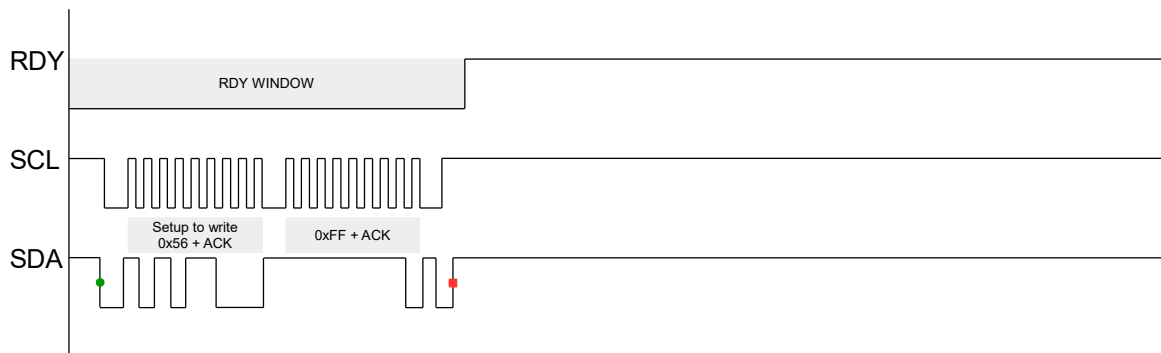

Figure 9.2: Force Stop Communication Sequence

## 9.10 Invalid Communications Return

The device will give an invalid communication response (0xEE) under the following conditions:

- > The host is trying to read from a memory map register that does not exist.
- > The host is trying to read from the device outside a communication window (while RDY is high).

## 9.11 I<sup>2</sup>C Interface

The IQS7221E has two I<sup>2</sup>C interface options, as described in the sections below.

### 9.11.1 I<sup>2</sup>C Streaming

I<sup>2</sup>C streaming mode refers to constant data reporting at the relevant power mode report rate specified in the **report rate registers**. The IQS7221E will pull the RDY line low to open a new communication window at the end of every single cycle. This mode is useful when streaming the device in the accompanying debug software.

### 9.11.2 I<sup>2</sup>C Event Mode

The device can be set up to bypass the communication window when no activity is sensed. This is usually enabled since the master does not need to be interrupted unnecessarily during every cycle if no activity has occurred, reducing current consumption. The device will provide a communications window when one of the enabled events occurs.

Event mode is described in more detail in Section 9.12.



## 9.12 Event Mode Communication

Event mode can only be entered if the following requirements are met:

- > Events must be serviced by reading from the **global events** register to ensure all events flags are cleared, otherwise continuous reporting (RDY interrupts) will persist after every cycle similar to streaming mode.
- > The **device reset** bit has been cleared by setting the **ACK reset** bit.

### 9.12.1 Events

Numerous events can be individually enabled to trigger communication. Bit definitions can be found in Table A.9.

- > Power mode change
- > Prox and touch events
- > ATI event
- > Hall events

### 9.12.2 Force Communication

In streaming mode, the IQS7221E I<sup>2</sup>C will provide RDY windows at regular intervals specified by the relevant power mode report rate. This will provide the master with regular opportunities to perform I<sup>2</sup>C communication as necessary.

If the device is placed in Event Mode, Standalone Mode, or Halt mode, the IQS7221E will not open RDY windows unless certain conditions are met. A new RDY window can be requested by writing 0xFF over I<sup>2</sup>C, followed by a stop condition. After a short delay, the IQS7221E will pull the RDY line low and open a new communication window. This is shown in Figure 9.3.

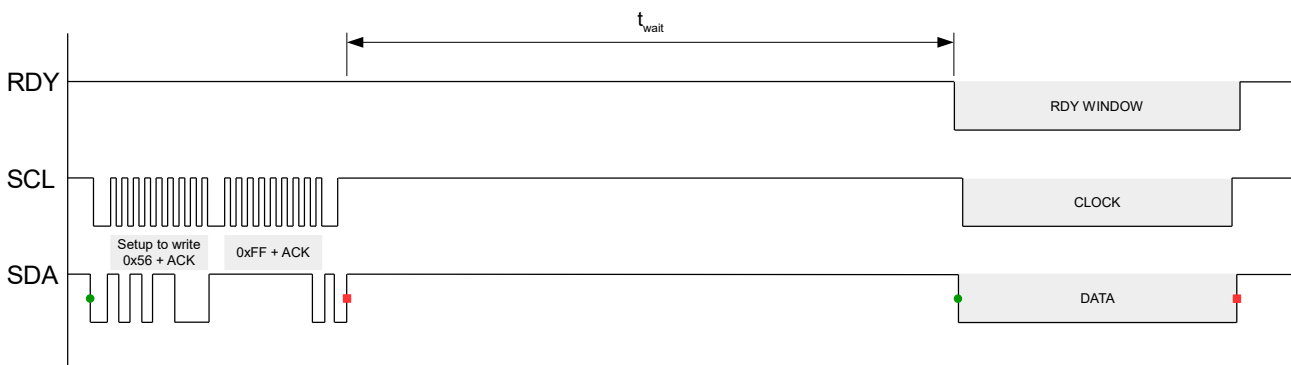

Figure 9.3: Force Communication Sequence

The minimum and maximum time between the communication request and the opening of a RDY window ( $t_{wait}$ ) is application specific, but the average values are  $0.1 \text{ ms} \leq t_{wait} \leq 45 \text{ ms}^i$ .

<sup>i</sup>Please contact Azoteq for an application specific value of  $t_{wait}$ .



## 10 I<sup>2</sup>C Memory Map

See Appendix A for more detailed descriptions of registers and bit definitions.

The IQS7221E uses two's complement to represent signed values.

Table 10.1: I<sup>2</sup>C Memory Map

Address	Data (16-bit)	Notes	
0x00 - 0x02	Version details	See Table A.1	
<b>Read Only</b>			
0x10	System Status	See Table A.2	
0x11	Global Events	See Table A.3	
0x12	Hall UI Flags	See Table A.4	
0x13	Touch Event States	See Table A.5	
0x14	Freewheel UI Flags	See Table A.6	
<b>Read Only Hall UI Data 0</b>			
0x20	Interval	16-bit value	
0x21	Processed Angle	0 – 65535	
0x22	Absolute Angle		
0x23	Field Differential A0B1	32-bit signed value	
0x24		(LSB First)	
0x25	Field Differential A1B0	32-bit signed value	
0x26		(LSB First)	
0x27	Interval Upper Limit	16-bit value	
0x28	Interval Lower Limit		
<b>Read Only Channel Counts</b>			
0x40	Raw Button Counts	16-bit value	
0x41	Filtered Button Counts		
0x42	Button LTA		
0x43	Button Delta	Signed 16-bit	
0x44	Hall Reference A0	16-bit value	
0x45	Hall Reference B1		
0x46	Hall Reference A1		
0x47	Hall Reference B0		
0x48	Hall Plate A0 Normal Counts		
0x49	Hall Plate A0 Inverted Counts		
0x4A	Hall Plate B1 Normal Counts		
0x4B	Hall Plate B1 Inverted Counts		
0x4C	Hall Plate A1 Normal Counts		
0x4D	Hall Plate A1 Inverted Counts		
0x4E	Hall Plate B0 Normal Counts		
0x4F	Hall Plate B0 Inverted Counts		
<b>Read Only Freewheel Data</b>			
0x53	Relative Speed		16-bit value
<b>Read-Write Flags and Data</b>			
0x60	System Settings	See Table A.7	
0x61	I <sup>2</sup> C Settings	See Table A.8	
0x62	High-accuracy Mode Report Rate	16-bit value	
0x63	Normal Power Report Rate		
0x64	Low Power Report Rate		
0x65	Ultra-low Power Report Rate		
0x66	ULP Timeout		





0x67	Event Mask	See Table A.9
0x68	Quadrature Flank Delay	16-bit value
0x69	Quadrature Mode	See Table A.10
0x6A	Watchdog Timeout	16-bit value
0x6B	Hall Post-setup Stabilisation Delay	
<b>Read-Write Hall UI Settings</b>		
0x70	Wheel-to-magnet Angle Offset	32-bit value
0x71		
0x72	Filter Switch Delta	16-bit value
0x73	Reserved	
0x74	Interval Hysteresis	
0x75	Number of Intervals	
0x76	High-accuracy Timeout	
0x77	Stationary Timeout	
0x78	Filter Betas	See Table A.11
0x79		See Table A.12
0x7A	UI Settings	See Table A.13
<b>Read-Write Hall Plate Settings</b>		
0x80	Hall Plate Fine and Coarse Multipliers	See Table A.14
0x81		
0x82	Hall Plate Bias	See Table A.15
0x83		See Table A.16
<b>Read-Write Freewheel Settings</b>		
0x90	Filter Betas	See Table A.17
0x91	Freewheel Friction	16-bit value
0x92	Freewheel Damping	
0x93	Freewheel Inertia	
0x94	Freewheel Starting Speed	
0x95	Freewheel Stop Speed	
0x98	Freewheel Touch Thresholds	See Table A.18
0x99		See Table A.19
<b>Read-Write Hall ATI Settings</b>		
0xA0	Target Min	16-bit value
0xA1	Target Max	
0xA2	ATI Settings	See Table A.20
<b>Read-Write Button Settings</b>		
0xB0	Prox Timeout	16-bit value
0xB1	Touch Timeout	
0xB2	Dormancy Timeout	
0xB3	ATI Timeout	
0xB4	Counts Betas	See Table A.21
0xB5	LTA Betas	See Table A.22
0xB6	Fast LTA Betas	See Table A.23
0xB7	Fast Bound / Reseed / ATI Band Fraction	See Table A.24
<b>Read-Write Button Sensor Settings</b>		
0xC0	Button Control 0	See Table A.25
0xC1	Button Control 1	See Table A.26
0xC2	CTx Select	16-bit value
0xC3	Button settings	See Table A.27
0xC4	ATI Base	16-bit value
0xC5	ATI Target	



0xC6	Button Fine and Coarse Multipliers	See Table A.28
0xC7	Button Compensation	See Table A.29
<b>Read-Write</b>	<b>Button Event Settings</b>	
0xD0	Prox Threshold	See Table A.30
0xD1	Touch Threshold	See Table A.31
<b>Read-Write</b>	<b>Button Event Settings</b>	
0xE0	I <sup>2</sup> C Transaction Timeout	16-bit value



## 11 Ordering Information

### 11.1 Ordering Code

Table 11.1: Order Code Description

IQS7221E001 ppb

IC NAME	IQS7221E001	=	IQS7221E001
		=	CS WLCSP-18 package
PACKAGE TYPE	pp	=	QN QFN-20 package
		=	QF QFN-20 package
BULK PACKAGING	b	=	R QFN-20 Reel (2000pcs/reel)
			WLCSP-18 Reel (3000pcs/reel)

### 11.2 Top Marking

#### 11.2.1 WLCSP18 Package Marking Option 1

Package outline can be found in Section 12.3.

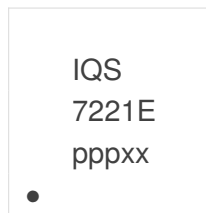

Product Name  
ppp = Product Code  
xx = Batch Code

#### 11.2.2 WLCSP18 Package Marking Option 2

Package outline can be found in Section 12.3.

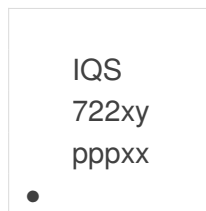

Product Name  
ppp = Product Code  
xx = Batch Code

#### 11.2.3 QFN20 Package Marking Option 1 (IQS7221E001QFR)

Package outline can be found in Section 12.1.

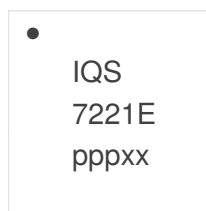

Product Name  
ppp = Product Code  
xx = Batch Code



#### 11.2.4 QFN20 Package Marking Option 2 (IQS7221E001QNR)

Package outline can be found in Section 12.2.

•  
IQS  
722xy  
pppx

Product Name  
ppp = Product Code  
xx = Batch Code

## 12 Package Specification

### 12.1 Package Outline Description – QFN20 (QFR)

This package outline is specific to order codes ending in *QFR*.

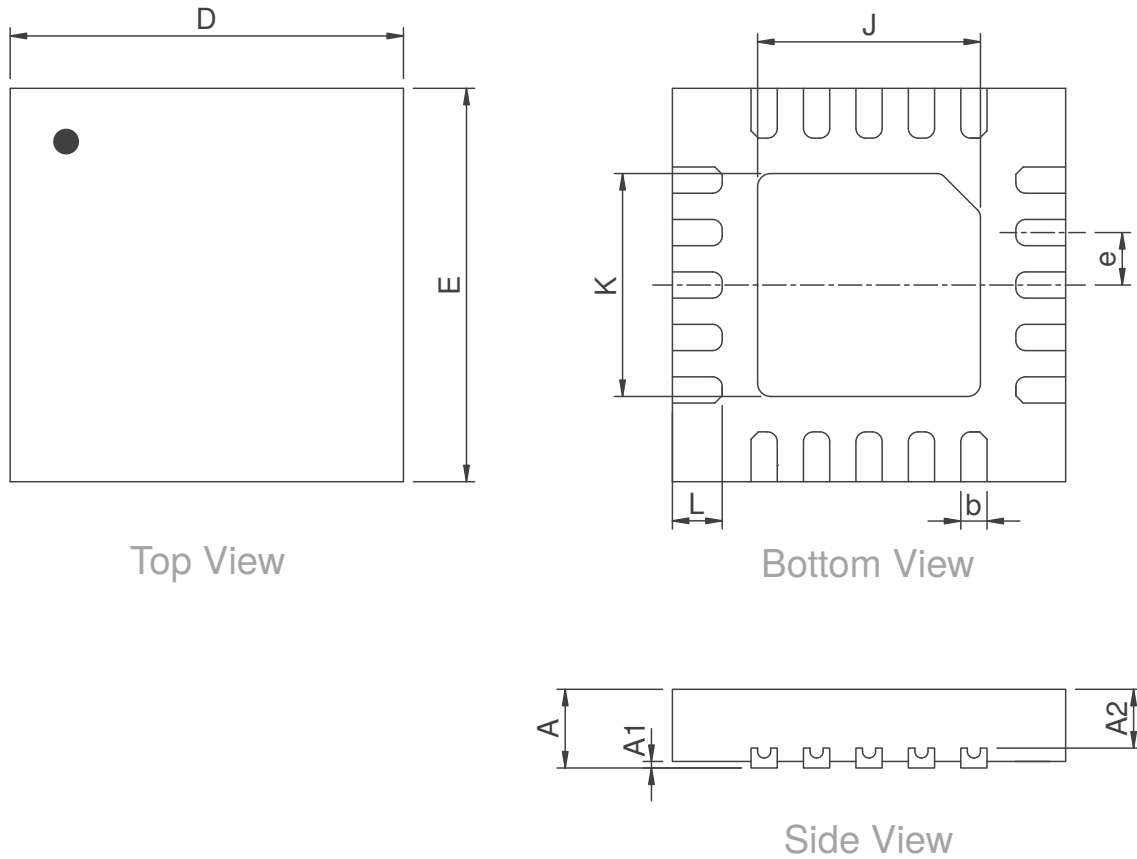

Figure 12.1: QFN (3x3)-20 (QFR) Package Outline Visual Description

Table 12.1: QFN (3x3)-20 Package Outline Visual Description

Dimension	[mm]	Dimension	[mm]
A	$0.55 \pm 0.05$	E	3
A1	$0.035 \pm 0.05$	e	0.4
A2	0.3	J	$1.7 \pm 0.1$
b	$0.2 \pm 0.05$	K	$1.7 \pm 0.1$
D	3	L	$0.3 \pm 0.05$

## 12.2 Package Outline Description – QFN20 (QNR)

This package outline is specific to order codes ending in *QNR*.

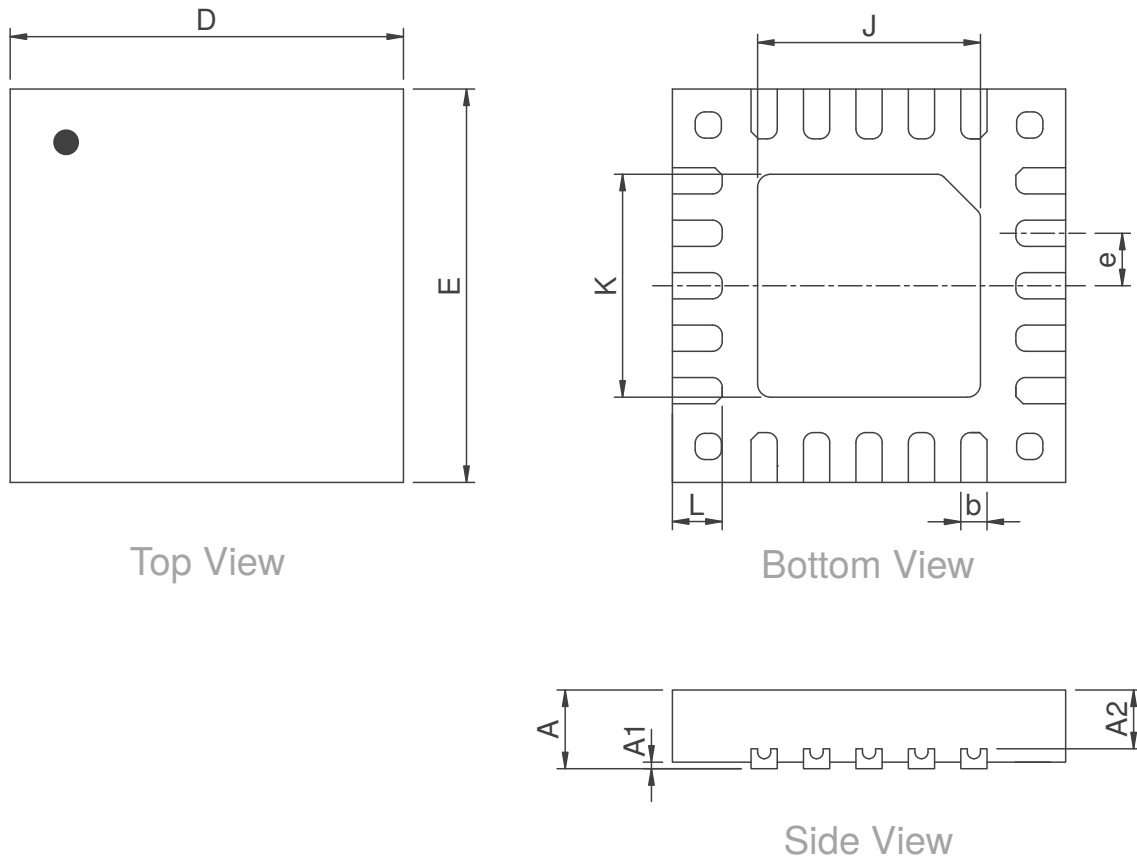

Figure 12.2: QFN (3x3)-20 (QNR) Package Outline Visual Description

Table 12.2: QFN (3x3)-20 Package Outline Visual Description

Dimension	[mm]	Dimension	[mm]
A	$0.55 \pm 0.05$	E	3
A1	$0.035 \pm 0.05$	e	0.4
A2	0.3	J	$1.7 \pm 0.1$
b	$0.2 \pm 0.05$	K	$1.7 \pm 0.1$
D	3	L	$0.38 \pm 0.05$

### 12.3 Package Outline Description – WLCSP18

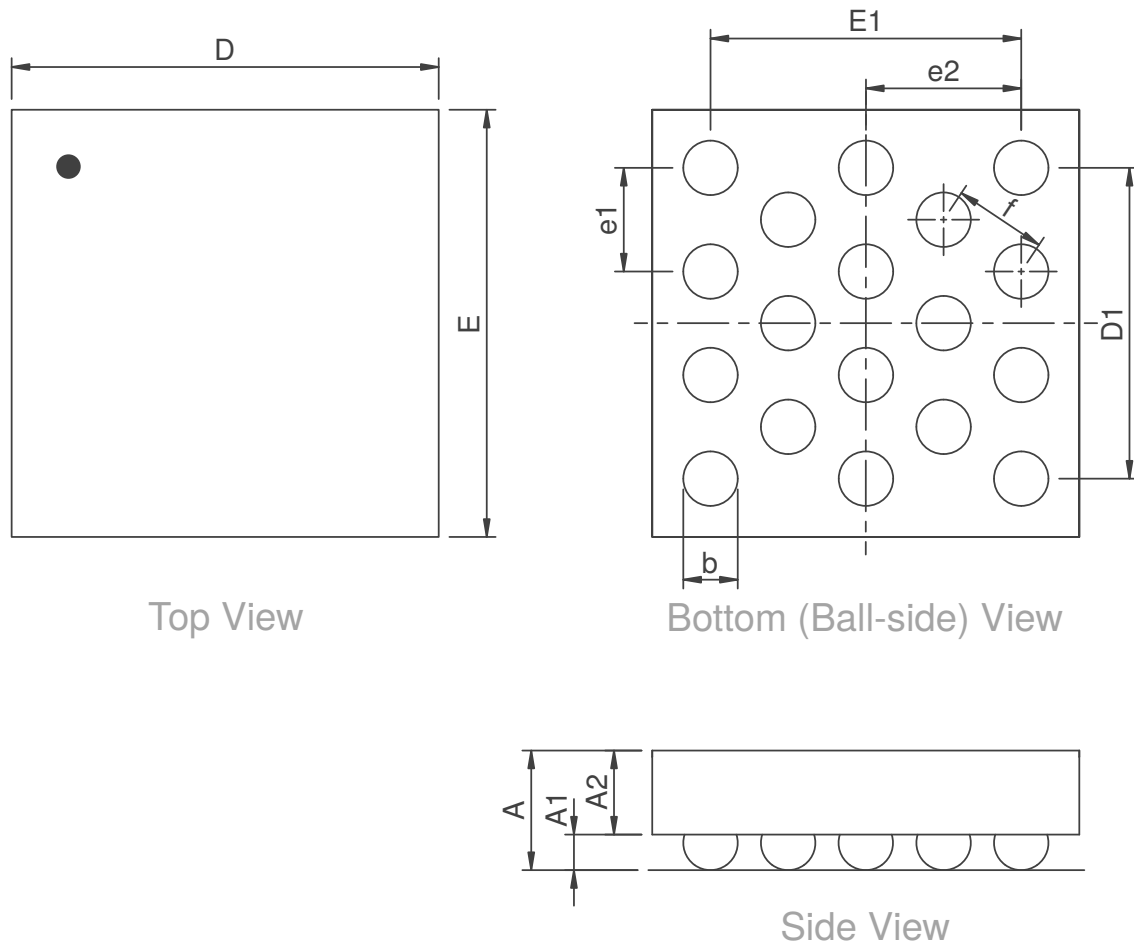

Figure 12.3: WLCSP (1.62x1.62)-18 Package Outline Visual Description

Table 12.3: WLCSP (1.62x1.62)-18 Package Outline Visual Description

Dimension	[mm]	Dimension	[mm]
A	0.525 ± 0.05	E	1.620 ± 0.015
A1	0.2 ± 0.02	E1	1.2
A2	0.3 ± 0.025	e1	0.4
b	0.260 ± 0.039	e2	0.6
D	1.620 ± 0.015	f	0.36
D1	1.2		

## 12.4 Tape and Reel Specifications

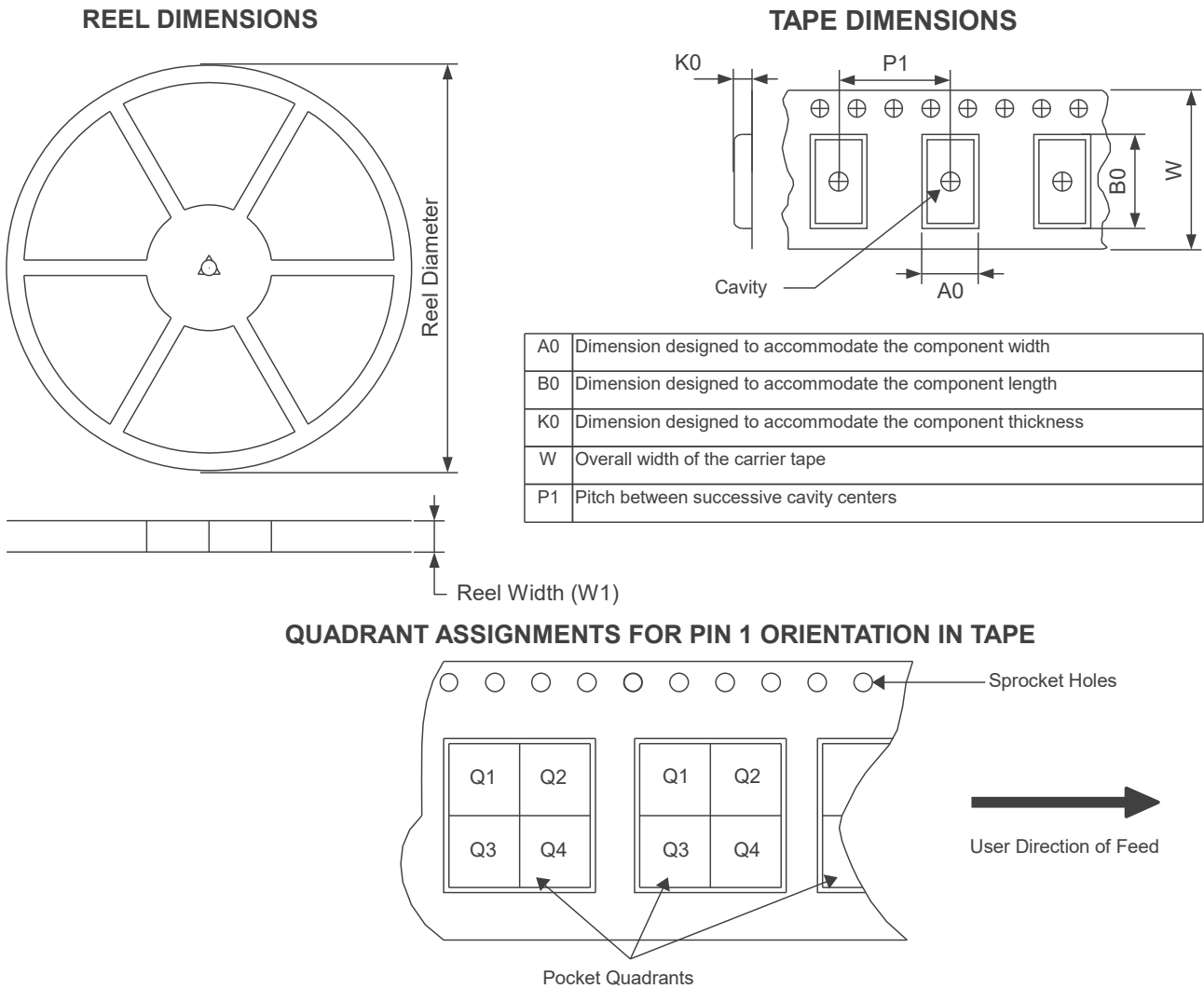

Figure 12.4: Tape and Reel Specification

Table 12.4: Tape and Reel Specifications

Package Type	Pins	Reel Diameter (mm)	Reel Width (mm)	A0 (mm)	B0 (mm)	K0 (mm)	P1 (mm)	W (mm)	Pin1 Quadrant
QFN20	20	180	12.4	3.3	3.3	0.8	8	12	Q2
WLCSP18	18	179	8.4	1.78	1.78	0.69	4	8	Q1





## 12.5 Moisture Sensitivity Levels

*Table 12.5: Moisture Sensitivity Levels*

Package	MSL
QFN20	1
WLCSP18	1

## 12.6 Reflow Specifications

Contact Azoteq



## A Memory Map Descriptions

Table A.1: Version Information

Address	Category	Name	Value
0x00	Application Version Info	Product Number	1283
0x01		Major Version	1
0x02		Minor Version	1

Table A.2: System Status

System Status (0x10)															
Bit15	Bit14	Bit13	Bit12	Bit11	Bit10	Bit9	Bit8	Bit7	Bit6	Bit5	Bit4	Bit3	Bit2	Bit1	Bit0
Reserved										Power mode			Reset	ATI Active	

> **Bit 2-5: Power Mode**

- 0: High-accuracy
- 1: Normal power
- 2: Low power
- 4: Ultra low power
- 8: Halt mode

> **Bit 1: Device Reset**

- 0: No reset occurred
- 1: Reset occurred

> **Bit 0: ATI Active**

- 0: ATI not active
- 1: ATI active

Table A.3: Global Events

Global Events (0x11)															
Bit15	Bit14	Bit13	Bit12	Bit11	Bit10	Bit9	Bit8	Bit7	Bit6	Bit5	Bit4	Bit3	Bit2	Bit1	Bit0
Reserved											Hall Event	Prox Event	Touch Event	ATI Event	Power Event

> **Bit 4: Hall Event**

- 0: No Hall event occurred
- 1: Hall event occurred

> **Bit 3: Prox Event**

- 0: No proximity event occurred
- 1: Proximity event occurred

> **Bit 2: Touch Event**

- 0: No touch event occurred
- 1: Touch event occurred

> **Bit 1: ATI Event**

- 0: No ATI event occurred
- 1: ATI event occurred

> **Bit 0: Power Event**

- 0: No power event occurred
- 1: Power event occurred



Table A.4: Hall UI Flags

Hall UI Flags (0x12)															
Bit15	Bit14	Bit13	Bit12	Bit11	Bit10	Bit9	Bit8	Bit7	Bit6	Bit5	Bit4	Bit3	Bit2	Bit1	Bit0
Reserved										Fast Filter	Reserved	High-accuracy	Stationary	Direction	Interval Changed

- > **Bit 5: Fast Filter**
  - 0: Fast filter is not active
  - 1: Fast filter is active
- > **Bit 3: High-accuracy**
  - 0: Device not in high-accuracy mode
  - 1: Device in high-accuracy mode
- > **Bit 2: Stationary**
  - This bit will be cleared on freewheeling interval change.
  - 0: Device is not stationary
  - 1: Device is stationary
- > **Bit 1: Direction**
  - 0: Reverse rotation sampled
  - 1: Forward rotation sampled
- > **Bit 0: Interval Changed**
  - 0: Interval change did not occur
  - 1: Interval change occurred

Table A.5: Touch Event States

Touch Event States (0x13)															
Bit15	Bit14	Bit13	Bit12	Bit11	Bit10	Bit9	Bit8	Bit7	Bit6	Bit5	Bit4	Bit3	Bit2	Bit1	Bit0
Reserved					Debounce	Direction	Dormant	Reserved					Touch	Prox	

- > **Bit 10: Debounce**
  - 0: Touch channel not in debounce state
  - 1: Touch channel in debounce state
- > **Bit 9: Direction**
  - 0: Negative delta for touch channel
  - 1: Positive delta for touch channel
- > **Bit 8: Dormant**
  - 0: Touch channel is not in dormant state
  - 1: Dormancy timeout occurred and touch channel is in dormant state
- > **Bit 1: Touch**
  - 0: Touch event is not active
  - 1: Touch event is active
- > **Bit 0: Prox**
  - 0: Prox event is not active
  - 1: Prox event is active

Table A.6: Freewheel UI Flags

Freewheel UI Flags (0x14)															
Bit15	Bit14	Bit13	Bit12	Bit11	Bit10	Bit9	Bit8	Bit7	Bit6	Bit5	Bit4	Bit3	Bit2	Bit1	Bit0
Reserved												Touch Exit	Touch Enter	Stationary	Free-wheeling

- > **Bit 3: Touch Exit**
  - 0: Touch exit event did not occur
  - 1: Touch exit event occurred
- > **Bit 2: Touch Enter**
  - 0: Touch enter event did not occur
  - 1: Touch enter event occurred



- > **Bit 1: Stationary**
  - This bit will not be cleared on freewheeling interval change.
  - 0: Device is not stationary
  - 1: Device is stationary
- > **Bit 0: Freewheeling**
  - 0: Freewheeling is inactive
  - 1: Freewheeling is active

Table A.7: System Settings

System Settings (0x60)															
Bit15	Bit14	Bit13	Bit12	Bit11	Bit10	Bit9	Bit8	Bit7	Bit6	Bit5	Bit4	Bit3	Bit2	Bit1	Bit0
Reserved	Enable ULP	Event Mode	Power Mode				Reserved			Comms in ATI	Hall Auto ATI	ACK Reset	Soft Reset	Force ATI	Stream

- > **Bit 14: Ultra-Low Power Enable**
  - 0: Device will not enter ultra-low power mode when automatic power mode switching is enabled
  - 1: Device can enter ultra-low power mode when automatic power mode switching is enabled. Only a touch event on Channel 0 will wake the device from ULP mode.
- > **Bit 13: Event Mode Enable**
  - 0: I<sup>2</sup>C Streaming Mode enabled
  - 1: Event Mode enabled
- > **Bit 8-12: Power Mode**
  - 0: High-accuracy mode
  - 1: Normal power mode
  - 2: Low power mode
  - 4: Ultra-low power mode
  - 8: Halt mode<sup>i</sup>
  - 9: Auto power mode
- > **Bit 5: Comms in ATI**
  - 0: Comms during ATI is disabled
  - 1: Comms during ATI is enabled
- > **Bit 4: Hall Runtime ATI**
  - 0: Hall runtime ATI disabled
  - 1: Hall runtime ATI enabled
- > **Bit 3: Acknowledge Reset**
  - 0: No effect
  - 1: Acknowledge reset
- > **Bit 2: Soft Reset**
  - 0: No effect
  - 1: Reset device
- > **Bit 1: Force ATI**
  - 0: No effect
  - 1: Execute ATI command
- > **Bit 0: Streaming enable**
  - 0: Enable standalone mode
  - 1: Enable I<sup>2</sup>C streaming mode

<sup>i</sup>Set WDT timeout > 4000 ms.



Table A.8: I<sup>2</sup>C Settings

I <sup>2</sup> C Settings (0x61)															
Bit15	Bit14	Bit13	Bit12	Bit11	Bit10	Bit9	Bit8	Bit7	Bit6	Bit5	Bit4	Bit3	Bit2	Bit1	Bit0
Reserved														RW Check	Stop End Comms

- > **Bit 1: Read-Write Check Disable**
  - 0: Read-Write check is enabled
  - 1: Read-Write check is disabled
- > **Bit 0: Stop Ends Comms Disable**
  - 0: Close I<sup>2</sup>C communications window on I<sup>2</sup>C stop condition
  - 1: Keep I<sup>2</sup>C communications window open until 0xFF command

Table A.9: Event Mask

Event Mask (0x67)															
Bit15	Bit14	Bit13	Bit12	Bit11	Bit10	Bit9	Bit8	Bit7	Bit6	Bit5	Bit4	Bit3	Bit2	Bit1	Bit0
Reserved											Hall Interval Event	Prox Event	Touch Event	ATI Event	Power Mode Event

- > **Bit 4: Hall Interval Event**
  - 0: Hall interval change event disabled
  - 1: Hall interval change event enabled
- > **Bit 3: Prox Event**
  - 0: Proximity event disabled
  - 1: Proximity event enabled
- > **Bit 2: Touch Event**
  - 0: Touch event disabled
  - 1: Touch event enabled
- > **Bit 1: ATI Event**
  - 0: ATI event disabled
  - 1: ATI event enabled
- > **Bit 0: Power Mode Event**
  - 0: Power mode event disabled
  - 1: Power mode event enabled

Table A.10: Quadrature Mode

Quadrature Mode (0x69)															
Bit15	Bit14	Bit13	Bit12	Bit11	Bit10	Bit9	Bit8	Bit7	Bit6	Bit5	Bit4	Bit3	Bit2	Bit1	Bit0
Reserved		Timer Expired	Encoder 1 State	Encoder 0 State	State			Reserved					Mode		

- > **Bit 13: Timer Expired**
  - 0: Quadrature state will not change
  - 1: Quadrature state is ready to change
- > **Bit 12: Encoder 1 State**
  - 0: Encoder 1 is in the LOW state
  - 1: Encoder 1 is in the HIGH state
- > **Bit 11: Encoder 0 State**
  - 0: Encoder 0 is in the LOW state
  - 1: Encoder 0 is in the HIGH state
- > **Bit 8-10: Quadrature State**
  - 0: Idle low
  - 1: Idle high
  - 2: Follow wait low
  - 3: Follow wait high
  - 4: Wait next



- > Bit 0-1: **Quadrature Mode**
  - 0: Off
  - 1: Open drain
  - 2: Push pull

Table A.11: Filter Betas 0

Filter Betas 0 (0x78)															
Bit15	Bit14	Bit13	Bit12	Bit11	Bit10	Bit9	Bit8	Bit7	Bit6	Bit5	Bit4	Bit3	Bit2	Bit1	Bit0
Fast Filter Beta								Slow Filter Beta							

- > Bit 8-15: **Fast Filter Beta**
  - Unsigned 8-bit value
- > Bit 0-7: **Slow Filter Beta**
  - Unsigned 8-bit value

Table A.12: Filter Betas 1

Filter Betas 1 (0x79)															
Bit15	Bit14	Bit13	Bit12	Bit11	Bit10	Bit9	Bit8	Bit7	Bit6	Bit5	Bit4	Bit3	Bit2	Bit1	Bit0
Auto Zero Beta								Low Power Filter Beta							

- > Bit 8-15: **Auto Zero Beta**
  - Unsigned 8-bit value
- > Bit 0-7: **Low Power Filter Beta**
  - Unsigned 8-bit value

Table A.13: Hall UI Settings

Hall UI Settings (0x7A)															
Bit15	Bit14	Bit13	Bit12	Bit11	Bit10	Bit9	Bit8	Bit7	Bit6	Bit5	Bit4	Bit3	Bit2	Bit1	Bit0
Reserved							Hall UI Enable	Discard Intervals	Force HA	Reverse Direction	Zero Now	Auto Zero Mode		Hall Sensor Enable	FW UI Enable

- > Bit 8: **Hall UI Enable**
  - 0: Hall UI disabled
  - 1: Hall UI enabled
- > Bit 7: **Discard Intervals**
  - 0: Keep missed intervals when stationary
  - 1: Discard missed intervals when stationary
- > Bit 6: **Force High-accuracy Mode during Freewheeling**
  - 0: Do not force High-accuracy report rate during freewheeling
  - 1: When freewheeling is active, always run at high-accuracy report rate (if auto-power modes are enabled)
- > Bit 5: **Reverse Direction**
  - 0: Normal rotation direction
  - 1: Reverse direction of sampled rotation
- > Bit 4: **Zero Now**
  - 0: No effect
  - 1: Execute zero command (Section 5.11) (Automatic clear after instruction)
- > Bit 2-3: **Auto Zero Mode**
  - 0: Off
  - 1: Stationary
  - 2: Continuous
  - 3: Release
- > Bit 1: **Hall Sensor Enable**
  - 0: Hall sensor disabled
  - 1: Hall sensor enabled
- > Bit 0: **Freewheel UI Enable**
  - 0: Freewheel UI disabled
  - 1: Freewheel UI enabled



Table A.14: Hall Fine and Coarse Multipliers

Hall Fine and Coarse Multipliers (0x80, 0x81)															
Bit15	Bit14	Bit13	Bit12	Bit11	Bit10	Bit9	Bit8	Bit7	Bit6	Bit5	Bit4	Bit3	Bit2	Bit1	Bit0
Reserved		Fine Fractional Divider					Coarse Fractional Multiplier				Coarse Fractional Divider				

- > **Bit 9-13: Fine Fractional Divider**
  - Unsigned 5-bit value
- > **Bit 5-8: Coarse Fractional Multiplier**
  - Unsigned 4-bit value
- > **Bit 0-4: Coarse Fractional Divider**
  - Unsigned 5-bit value

Table A.15: Hall Plate Bias 0

Hall Plate Bias 0 (0x82)															
Bit15	Bit14	Bit13	Bit12	Bit11	Bit10	Bit9	Bit8	Bit7	Bit6	Bit5	Bit4	Bit3	Bit2	Bit1	Bit0
B1 Bias								A0 Bias							

- > **Bit 8-15: B1 Bias**
  - Unsigned 8-bit value
- > **Bit 0-7: A0 Bias**
  - Unsigned 8-bit value

Table A.16: Hall Plate Bias 1

Hall Plate Bias 1 (0x83)															
Bit15	Bit14	Bit13	Bit12	Bit11	Bit10	Bit9	Bit8	Bit7	Bit6	Bit5	Bit4	Bit3	Bit2	Bit1	Bit0
B0 Bias								A1 Bias							

- > **Bit 8-15: B0 Bias**
  - Unsigned 8-bit value
- > **Bit 0-7: A1 Bias**
  - Unsigned 8-bit value

Table A.17: Freewheel Filter Betas

Freewheel Filter Betas (0x90)															
Bit15	Bit14	Bit13	Bit12	Bit11	Bit10	Bit9	Bit8	Bit7	Bit6	Bit5	Bit4	Bit3	Bit2	Bit1	Bit0
Follow Beta								Fast Decay Beta							

- > **Bit 8-15: Follow Beta**
  - Unsigned 8-bit value
- > **Bit 0-7: Fast Decay Beta**
  - Unsigned 8-bit value

Table A.18: Freewheel Touch Threshold 0

Freewheel Touch Threshold 0 (0x98)															
Bit15	Bit14	Bit13	Bit12	Bit11	Bit10	Bit9	Bit8	Bit7	Bit6	Bit5	Bit4	Bit3	Bit2	Bit1	Bit0
Forward Release Threshold								Stop Touch Threshold							

- > **Bit 8-15: Forward Release Threshold**
  - Unsigned 8-bit value
- > **Bit 0-7: Stop Touch Threshold**
  - Unsigned 8-bit value



Table A.19: Freewheel Touch Threshold 1

Freewheel Touch Threshold 1 (0x99)															
Bit15	Bit14	Bit13	Bit12	Bit11	Bit10	Bit9	Bit8	Bit7	Bit6	Bit5	Bit4	Bit3	Bit2	Bit1	Bit0
Reserved								Reverse Release Threshold							

- > **Bit 0-7: Reverse Release Threshold**
  - Unsigned 8-bit value

Table A.20: Hall ATI Settings

Hall ATI Settings (0xA2)															
Bit15	Bit14	Bit13	Bit12	Bit11	Bit10	Bit9	Bit8	Bit7	Bit6	Bit5	Bit4	Bit3	Bit2	Bit1	Bit0
Reserved								Band Error Fraction							

- > **Bit 0-7: Band Error Fraction**
  - Unsigned 8-bit value

Table A.21: Button Beta 0

Button Beta 0 (0xB4)															
Bit15	Bit14	Bit13	Bit12	Bit11	Bit10	Bit9	Bit8	Bit7	Bit6	Bit5	Bit4	Bit3	Bit2	Bit1	Bit0
Low Power Beta								Normal Power Beta							

- > **Bit 8-15: Low Power Beta**
  - Unsigned 8-bit value
- > **Bit 0-7: Normal Power Beta**
  - Unsigned 8-bit value

Table A.22: Button Beta 1

Button Beta 1 (0xB5)															
Bit15	Bit14	Bit13	Bit12	Bit11	Bit10	Bit9	Bit8	Bit7	Bit6	Bit5	Bit4	Bit3	Bit2	Bit1	Bit0
LTA Low Power Beta								LTA Normal Power Beta							

- > **Bit 8-15: LTA Low Power Beta**
  - Unsigned 8-bit value
- > **Bit 0-7: LTA Normal Power Beta**
  - Unsigned 8-bit value

Table A.23: Button Beta 2

Button Beta 2 (0xB6)															
Bit15	Bit14	Bit13	Bit12	Bit11	Bit10	Bit9	Bit8	Bit7	Bit6	Bit5	Bit4	Bit3	Bit2	Bit1	Bit0
LTA Low Power Fast Beta								LTA Normal Power Fast Beta							

- > **Bit 8-15: LTA Low Power Fast Beta**
  - Unsigned 8-bit value
- > **Bit 0-7: LTA Normal Power Fast Beta**
  - Unsigned 8-bit value





Table A.24: Button Fast Bound

Button Fast Bound (0xB7)															
Bit15	Bit14	Bit13	Bit12	Bit11	Bit10	Bit9	Bit8	Bit7	Bit6	Bit5	Bit4	Bit3	Bit2	Bit1	Bit0
ATI Band Fraction							Reseed Touch	Fast bound							

- > **Bit 9-15: ATI Band Fraction**
  - Unsigned 7-bit value
- > **Bit 8: Reseed Touch**
  - 0: No action taken
  - 1: Reseed touch channel (will reset after instruction)
- > **Bit 0-7: Fast Bound**
  - Unsigned 8-bit value

Table A.25: Button Control 0

Button Control 0 (0xC0)															
Bit15	Bit14	Bit13	Bit12	Bit11	Bit10	Bit9	Bit8	Bit7	Bit6	Bit5	Bit4	Bit3	Bit2	Bit1	Bit0
Fraction							Reserved	Vref 0v5	RF Filter	Reserved	Proj Bias	Max Count			

- > **Bit 8-15: Conversion Frequency Fraction**
  - $256 \times \frac{f_{fraction}}{f_{clk}}$
  - 8-bit value
- > **Bit 6: Vref 0v5**
  - 0: Vref 0v5 disabled, 1 V voltage reference
  - 1: Vref 0v5 enabled, 500 mV voltage reference
- > **Bit 5: RF Filter**
  - 0: Disable RF Filter
  - 1: Enable RF Filter
- > **Bit 2-3: Projected Bias**
  - 0: 2 uA
  - 1: 5 uA
  - 2: 6 uA
  - 3: 10 uA
- > **Bit 0-1: Max Counts**
  - 0: 1023
  - 1: 2047
  - 2: 4095
  - 3: 16384

Table A.26: Button Control 1

Button Control 1 (0xC1)															
Bit15	Bit14	Bit13	Bit12	Bit11	Bit10	Bit9	Bit8	Bit7	Bit6	Bit5	Bit4	Bit3	Bit2	Bit1	Bit0
CRx Select				80pF Cs	Cap Mode	Inactive VSS	Reserved	Period							

- > **Bit 12-15: CRx Select**
  - 4-bit value
- > **Bit 11: 80pF Cs**
  - 0: 40 pF internal reference capacitor (half resolution)
  - 1: 80 pF internal reference capacitor (full resolution)
- > **Bit 10: Capacitance mode**
  - 0: Self-capacitive mode
  - 1: Mutual-capacitive mode
- > **Bit 9: Inactive VSS**
  - 0: No action
  - 1: Connect all inactive Cx pins to VSS



> **Bit 0-7: Conversion Frequency Period**

- The calculation of the charge transfer frequency ( $f_{xfer}$ ) is shown below. The relevant formula is determined by the value of the dead time enabled bit.
- Dead time disabled:  $f_{xfer} = \frac{f_{clk}}{2 \times period + 2}$
- Dead time enabled:  $f_{xfer} = \frac{f_{clk}}{2 \times period + 3}$
- Note: if the conversion frequency fraction is fixed at 127 and dead time is enabled, the following values of the conversion period will result in the corresponding charge transfer frequencies:
  - \* 1: 2 MHz
  - \* 5: 1 MHz<sup>ii</sup>
  - \* 12: 500 kHz
  - \* 17: 350 kHz
  - \* 26: 250 kHz
  - \* 53: 125 kHz

Table A.27: Button Settings

Button Settings (0xC3)															
Bit15	Bit14	Bit13	Bit12	Bit11	Bit10	Bit9	Bit8	Bit7	Bit6	Bit5	Bit4	Bit3	Bit2	Bit1	Bit0
Reserved	Dead Time Enable	Reserved	Reserved	Auto Prox Cycles	Reserved	Reserved	Reserved	Reserved	Release UI	Dual Threshold	ATI Mode	ATI Mode	ATI Mode	Inverse	Enabled

> **Bit 14: Dead Time Enable**

- 0: Dead time disabled
- 1: Dead time enabled

> **Bit 10-11: Auto Prox Cycles**

- This bit defines the number of cycles between ULP communication windows.
- 0: 4
- 1: 8
- 2: 16
- 3: 32

> **Bit 6: Release UI**

- This bit will allow the reference channel to update during touch, resulting in a negative delta upon release.
- 0: Release UI disabled
- 1: Release UI enabled

> **Bit 5: Dual Threshold**

- This bit will allow touch events to trigger for both positive and negative touch delta values.
- 0: Dual threshold disabled
- 1: Dual threshold enabled

> **Bit 2-4: ATI Mode**

- 0: Disabled
- 1: Compensation only
- 2: From compensation divider
- 3: From fine divider
- 4: From coarse divider
- 5: Full

> **Bit 1: Inverse**

- This bit will affect the direction in which a touch event can be triggered. This bit must be enabled for the mutual-capacitive mode to function.
- 0: Inverse touch delta disabled
- 1: Inverse touch delta enabled

> **Bit 0: Enabled**

- 0: Touch button disabled
- 1: Touch button enabled

<sup>ii</sup>Please note: The maximum charge transfer frequency for mutual-capacitive mode is 1 MHz.



Table A.28: Button Fine and Coarse Multipliers

Button Fine and Coarse Multipliers (0xC6)															
Bit15	Bit14	Bit13	Bit12	Bit11	Bit10	Bit9	Bit8	Bit7	Bit6	Bit5	Bit4	Bit3	Bit2	Bit1	Bit0
Reserved		Fine Fractional Divider					Coarse Fractional Multiplier				Coarse Fractional Divider				

- > **Bit 9-13: Fine Fractional Divider**
  - Unsigned 5-bit value
- > **Bit 5-8: Coarse Fractional Multiplier**
  - Unsigned 4-bit value
- > **Bit 0-4: Coarse Fractional Divider**
  - Unsigned 5-bit value

Table A.29: Button Compensation

Button Compensation (0xC7)															
Bit15	Bit14	Bit13	Bit12	Bit11	Bit10	Bit9	Bit8	Bit7	Bit6	Bit5	Bit4	Bit3	Bit2	Bit1	Bit0
Compensation Divider					Reserved	Compensation Selection									

- > **Bit 11-15: Compensation Divider**
  - Unsigned 5-bit value
- > **Bit 0-9: Compensation Selection**
  - Unsigned 10-bit value

Table A.30: Prox Threshold

Prox Threshold (0xD0)															
Bit15	Bit14	Bit13	Bit12	Bit11	Bit10	Bit9	Bit8	Bit7	Bit6	Bit5	Bit4	Bit3	Bit2	Bit1	Bit0
Debounce Exit Prox				Debounce Enter Prox				Threshold Prox							

- > **Bit 12-15: Debounce Exit Prox**
  - Unsigned 4-bit value
- > **Bit 8-11: Debounce Enter Prox**
  - Unsigned 4-bit value
- > **Bit 0-7: Threshold Prox**
  - Unsigned 8-bit value

Table A.31: Touch Threshold

Touch Threshold (0xD1)															
Bit15	Bit14	Bit13	Bit12	Bit11	Bit10	Bit9	Bit8	Bit7	Bit6	Bit5	Bit4	Bit3	Bit2	Bit1	Bit0
Touch Hysteresis								Touch Threshold							

- > **Bit 8-15: Touch Hysteresis**
  - Unsigned 8-bit value
  - Hysteresis is calculated based on the touch threshold below:

$$\text{Hysteresis} = \frac{\text{Touch Threshold} \times 8\text{-bit value}}{256}$$

- > **Bit 0-7: Touch Threshold**
  - Unsigned 8-bit value
  - Threshold is calculated as:

$$\text{Touch Threshold} = \frac{\text{LTA} \times 8\text{-bit value}}{256}$$



## Contact Information

	USA	Asia	South Africa
<b>Physical Address</b>	11940 Jollyville Rd Suite 120-S Austin TX-78759 USA	Room501A, Block A T-Share International Centre Taoyuan Road Nanshan District Shenzhen Guangdong Province PRC	1 Bergsig Avenue Paarl 7646 South Africa
<b>Postal Address</b>	11940 Jollyville Rd Suite 120-S Austin TX-78759 USA	Room501A, Block A T-Share International Centre Taoyuan Road Nanshan District Shenzhen Guangdong Province PRC	PO Box 3534 Paarl 7620 South Africa
<b>Tel</b>	+1 512 538 1995	+86 755 8303 5294 ext 808	+27 21 863 0033
<b>Email</b>	info@azoteq.com	info@azoteq.com	info@azoteq.com

*Visit [www.azoteq.com](http://www.azoteq.com)  
for a list of distributors and worldwide representation.*

Patents as listed on [www.azoteq.com/patents-trademarks/](http://www.azoteq.com/patents-trademarks/) may relate to the device or usage of the device.

Azoteq®, Crystal Driver®, IQ Switch®, ProxSense®, ProxFusion®, LightSense™, SwipeSwitch™, and the  logo are trademarks of Azoteq.

The information in this Datasheet is believed to be accurate at the time of publication. Azoteq uses reasonable effort to maintain the information up-to-date and accurate, but does not warrant the accuracy, completeness or reliability of the information contained herein. All content and information are provided on an "as is" basis only, without any representations or warranties, express or implied, of any kind, including representations about the suitability of these products or information for any purpose. Azoteq disclaims all warranties and conditions with regard to these products and information, including but not limited to all implied warranties and conditions of merchantability, fitness for a particular purpose, title and non-infringement of any third party intellectual property rights. Azoteq assumes no liability for any damages or injury arising from any use of the information or the product or caused by, without limitation, failure of performance, error, omission, interruption, defect, delay in operation or transmission, even if Azoteq has been advised of the possibility of such damages. The applications mentioned herein are used solely for the purpose of illustration and Azoteq makes no warranty or representation that such applications will be suitable without further modification, nor recommends the use of its products for application that may present a risk to human life due to malfunction or otherwise. Azoteq products are not authorized for use as critical components in life support devices or systems. No licenses to patents are granted, implicitly, express or implied, by estoppel or otherwise, under any intellectual property rights. In the event that any of the abovementioned limitations or exclusions does not apply, it is agreed that Azoteq's total liability for all losses, damages and causes of action (in contract, tort (including without limitation, negligence) or otherwise) will not exceed the amount already paid by the customer for the products. Azoteq reserves the right to alter its products, to make corrections, deletions, modifications, enhancements, improvements and other changes to the content and information, its products, programs and services at any time or to move or discontinue any contents, products, programs or services without prior notification. For the most up-to-date information and binding Terms and Conditions please refer to [www.azoteq.com](http://www.azoteq.com).