

Electronic load switch for power line

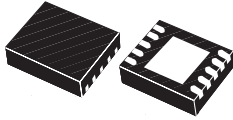

DFN10L (3x3 mm)

[Maturity status link](#)[STELPD01](#)

Features

- Wide input voltage range: 4 V to 18 V
- 17.5 V typical output overvoltage clamp
- Absolute maximum voltage of 23.5 V
- 5 A maximum continuous current
- Adjustable current limit with circuit breaker functionality
- Thermal protection
- Input undervoltage lockout
- Low inrush current during startup
- Integrated 40 mΩ Power FET
- EN/Fault pin
- Adjustable slew rate for output voltage
- Gate control pin for reverse current blocking FET
- Latch or auto-retry
- Available in DFN10L (3x3 mm) package

Applications

- Hot-Swap, Hot-Plug protection
- Industrial Systems
- VBUS management for Type-C and USB PD applications

Description

The **STELPD01** is an integrated electronic power switch for power rail protection applications.

It is able to precisely detect and react to overcurrent and overvoltage conditions.

When an overload condition occurs, the device goes into an open state, disconnecting the load from the power supply. An external power MOSFET can be driven to manage the power loss protection in case of fault condition.

In case of overvoltage on the input, the device regulates the output to a preset 17.5 V value.

Undervoltage lockout prevents the load from malfunction, keeping the device off if the rail voltage is too low.

The **STELPD01** features an adjustable turn-on slew-rate, which is useful to keep the in-rush current under control during startup and hot-swap operations.

1 Diagram

Figure 1. Block diagram

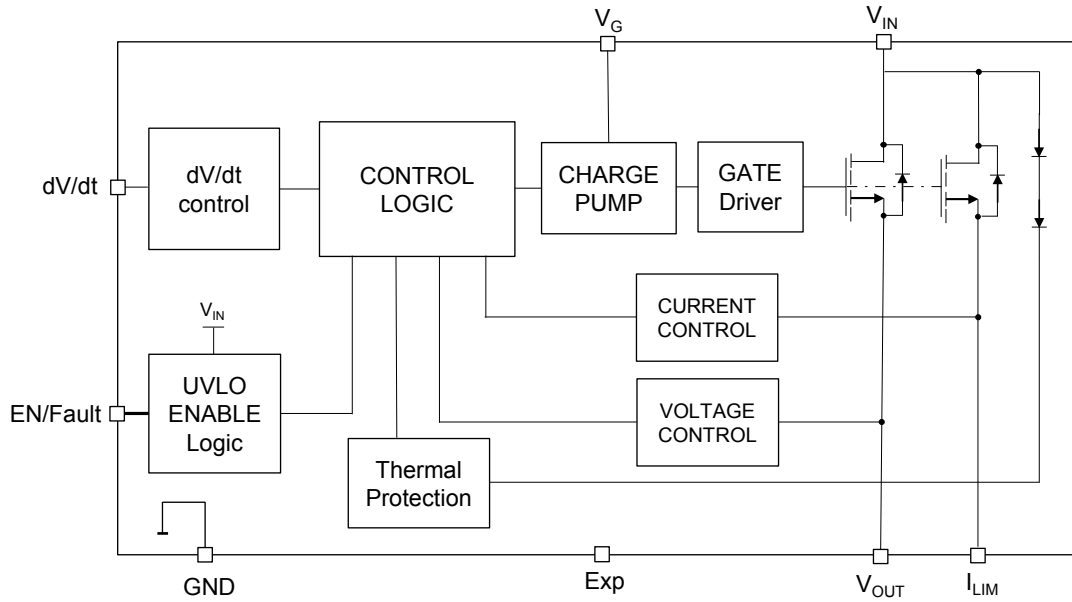

2 Pin configuration

Figure 2. Pin connection (top view)

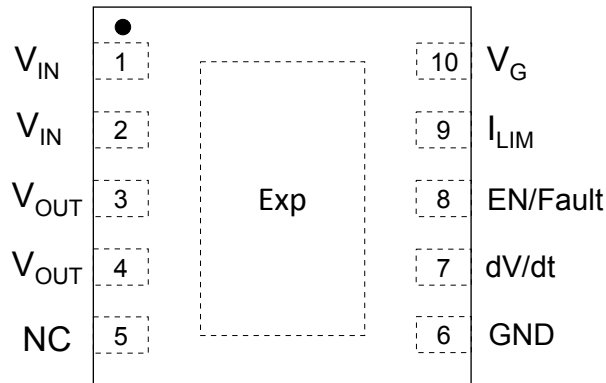
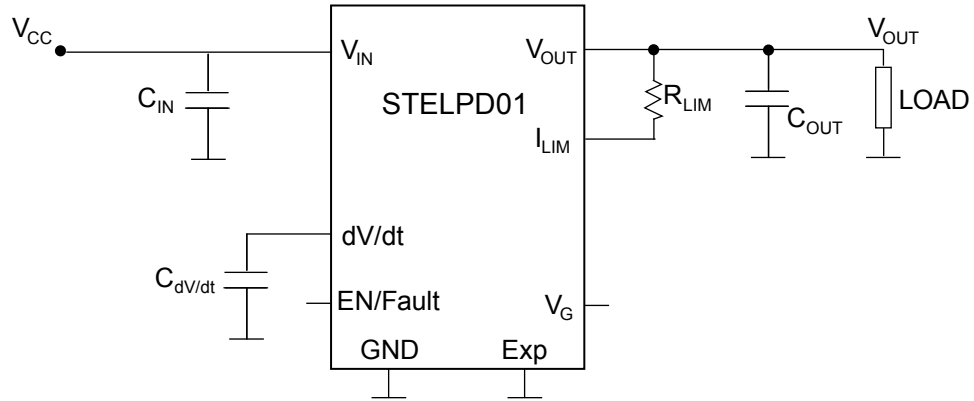
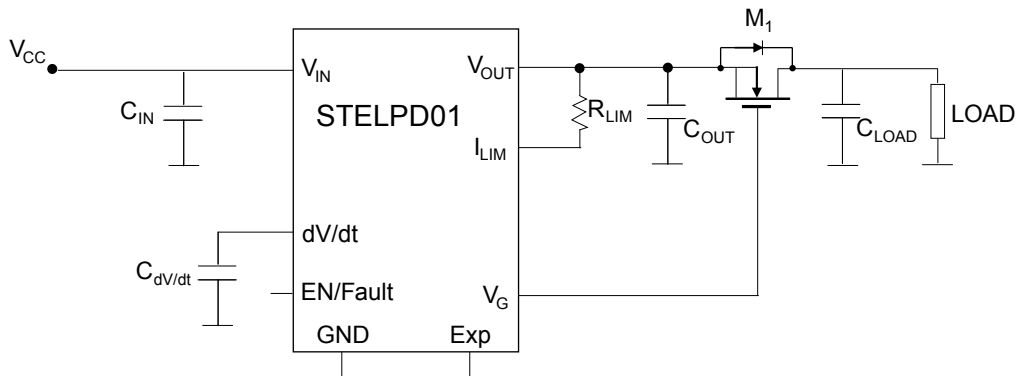

Table 1. Pin description

Pin n°	Symbol	Function
1-2	V_{IN}	Positive input voltage.
3-4	V_{OUT}	Connected to the source of the internal power MOSFET.
5	NC	Not connected.
6	GND	Ground.
7	dV/dt	Soft-start adjustment pin. The internal dV/dt circuit controls the slew rate of the output voltage at turn-on. The internal capacitor allows a fixed ramp-up time but an external capacitor can be added to this pin to increase the ramp time. If an additional capacitor is not required, this pin should be left open.
8	EN/Fault	The EN/Fault pin is a tri-state, bi-directional interface. During normal operation the pin can be left floating, it is internally pulled up to 5 V. It can be used to disable the output of the device by pulling it to ground using an open drain or open collector device. See Section 6.1 , Section 6.5 , Section 6.6 and Section 6.7 for other specific functions of this pin according to the device versions.
9	$I_{LIM}^{(1)}$	An R_{LIM} resistor between this pin and the V_{OUT} pin sets the overload current limit threshold.
10	V_G	External gate driver pin. An external power MOSFET can be connected to implement the reverse current protection.
	Exp	The device's package uses the center pad as a thermal conduit. This pad should be connected to an adequate spread of copper. GND connection is suggested.

1. Important: missing or shorted R_{LIM} causes current limit circuit malfunction and may lead to device damage.

3 Application circuits

Figure 3. Typical application circuit

Figure 4. Typical application circuit with reverse current protection

Table 2. Typical application components

Symbol	Value	Description	Note
C_{IN}	1 μ F	Input capacitor	This value should be increased depending on input inductance and load current.
$C_{dV/dt}$	560 pF	Soft-start capacitor	This value depends on the desired soft-start time.
R_{LIM}	51 Ω	Current limitation resistor	This value depends on the desired current limit threshold.
C_{OUT}	10 μ F	Output capacitor	

4 Maximum ratings

Table 3. Absolute maximum ratings

Symbol	Parameter	Value	Unit
V _{IN}	Power supply input voltage	-0.3 to 23.5	V
V _{OUT}	Output voltage	-0.3 to V _{IN} + 0.3	V
I _{LIM}	Current limit resistor pin voltage	-0.3 to 23.5	V
EN/Fault	EN/Fault pin voltage	-0.3 to 7	V
dV/dt	dV/dt pin voltage	-0.3 to 7	V
V _G	External gate driver pin voltage	-0.3 to 23.5	V
T _{J-OP}	Operating junction temperature range ⁽¹⁾	-40 to 125	°C
T _{J-MAX}	Maximum junction temperature	125	°C
T _{STG}	Storage temperature range	-55 to 150	°C
T _{LEAD}	Lead temperature (soldering) 10 sec	260	°C

1. The thermal limit is set above the maximum thermal rating. It is not recommended to operate the device at temperatures greater than the maximum ratings for extended periods.

Note: Absolute maximum ratings are those values beyond which damage to the device may occur. Functional operation under these conditions is not implied. All values are referred to GND.

Table 4. Thermal data

Symbol	Parameter	Value	Unit
R _{thJA}	Thermal resistance junction-ambient ⁽¹⁾	53	°C/W
R _{thJC}	Thermal resistance junction-case	18	°C/W

1. Based on JESD51-7, 4-layer PCB.

Table 5. ESD performance

Symbol	Parameter	Test conditions	Value	Unit
ESD	ESD protection voltage	HBM	2	kV
		CDM	500	V

Table 6. Recommended operating condition

Symbol	Parameter	Value	Unit
V _{IN}	Operating power supply input voltage	4 to 16.8	V
I _D	Maximum continuous current T _A = 25 °C ⁽¹⁾	5	A
C _{IN}	Minimum input capacitor	1	μF
C _{OUT}	Minimum output capacitor	1	μF

1. The maximum allowable power dissipation is a function of the maximum junction temperature T_{J(MAX)}, the junction-to-ambient thermal resistance θ_{JA}, and the ambient temperature T_A and can be estimated by: P_{D(MAX)} = (T_{J(MAX)} - T_A) / θ_{JA}. Exceeding the maximum allowable power dissipation produces overheating that may cause thermal shutdown.

5 Electrical characteristics

$V_{IN} = 5\text{ V}$, $V_{EN/Fault} = 5\text{ V}$, $C_{IN} = 10\text{ }\mu\text{F}$, $C_{OUT} = 10\text{ }\mu\text{F}$, $C_{dV/dt} = \text{floating}$, $R_{LIM} = 22\text{ }\Omega$; $T_J = 25\text{ }^\circ\text{C}$; unless otherwise specified.

Table 7. Electrical characteristics

Symbol	Parameter	Test conditions	Min.	Typ.	Max.	Unit
Under/Overshoot protection						
V_{CLAMP}	Clamping voltage	$I_{OUT} = 10\text{ mA}$	16.8	17.5	18.2	V
V_{UVLO}	V_{IN} undervoltage lockout	Turn-on, V_{IN} rising	2.85	2.9	2.95	V
		Hysteresis		150		mV
Power MOSFET						
T_{DELAY}	Delay time	Enabling of chip to soft-start beginning (10% of V_{OUT}), No $C_{dV/dt}$		165		μs
R_{DSon}	On-resistance ⁽¹⁾	$T_J = 25\text{ }^\circ\text{C}$, $I_{OUT} = 500\text{ mA}$		42	52	m Ω
		$T_J = 85\text{ }^\circ\text{C}$ ⁽²⁾		50		
		$V_{IN} = 15\text{ V}$, $T_J = 25\text{ }^\circ\text{C}$, $I_{OUT} = 500\text{ mA}$		40	50	
		$V_{IN} = 15\text{ V}$, $T_J = 85\text{ }^\circ\text{C}$ ⁽²⁾		48		
V_{OFF}	Off-state output voltage	$V_{IN} = 18\text{ V}$, $R_L = \text{infinite}$, EN/Fault connected to ground		1	3	mV
Current limit						
I_{LIM}	Overcurrent limit threshold	$R_{LIM} = 22\text{ }\Omega$		5.15		A
		$R_{LIM} = 51\text{ }\Omega$		3		
dV/dt circuit						
dV/dt	Output voltage ramp time	From 10% to 90% of V_{OUT} , No CdV/dt		500		μs
Blocking FET gate driver						
I_{FET}	External FET charging current	Device on		30		μA
V_{FETmax}	External FET clamp voltage	$V_{IN} = 9\text{ V}$, $V_G - V_{OUT}$		4.6		V
$R_{FETdisch}$	External FET discharging current	$V_{EN/Fault} = 0\text{ V}$, $V_G = V_{IN}$		7.5		mA
T_{PLP}	PLP intervention time	From EN/Fault = 0 V or $V_{IN} < V_{UVLO}$ to $V_G < 1\text{ V}$		1		μs
EN/Fault						
V_{IL}	Low level input voltage threshold	Output disabled			0.4	V
$V_{I(INT)}$	Intermediate level input voltage	Thermal fault, output disabled	750	825	900	mV
V_{IH}	High level input voltage threshold		2.55			V
$V_{I(MAX)}$	High state maximum voltage	$V_{IN} = 5\text{ V}$		4.9		V
		$V_{IN} = 15\text{ V}$		4.95		
I_{IL}	Low level input current (sink)	$V_{EN/Fault} = 0\text{ V}$		-100	-140	μA
I_{IH}	High level leakage current for external switch	$V_{EN/Fault} = 5\text{ V}$		1		μA

Symbol	Parameter	Test conditions	Min.	Typ.	Max.	Unit
Thermal protection						
T_{SHDN}	Thermal shutdown ⁽³⁾			165		°C
T_{SHDN_HYS}	Hysteresis			20		°C
Current consumption						
I_{BIAS}	Bias current, device operational	$V_{IN} = 5\text{ V}$		300		μA
		$V_{IN} = 15\text{ V}$		350		
	Bias current, fault mode	$V_{IN} = 5\text{ V}$		115		μA
		$V_{IN} = 15\text{ V}$		135		
	Bias current, off mode	$V_{IN} = 5\text{ V}, V_{EN/Fault} = 0\text{ V}$		200		μA
		$V_{IN} = 15\text{ V}, V_{EN/Fault} = 0\text{ V}$		225		

1. Pulsed test.
2. Values across temperature range are guaranteed by design/correlation and tested in production only at ambient temperature.
3. Guaranteed by design, but not tested in production.

6 Functional description

6.1 Turn-on and soft start-up feature

When the input voltage is applied and it reaches V_{UVLO} (undervoltage lockout threshold) value, the EN/Fault pin goes up to the high state (if left floating) and the internal control circuitry is enabled to perform the output start-up ramp. See the figure below.

Figure 5. Typical startup sequence for STELPD01 and STELPD01A

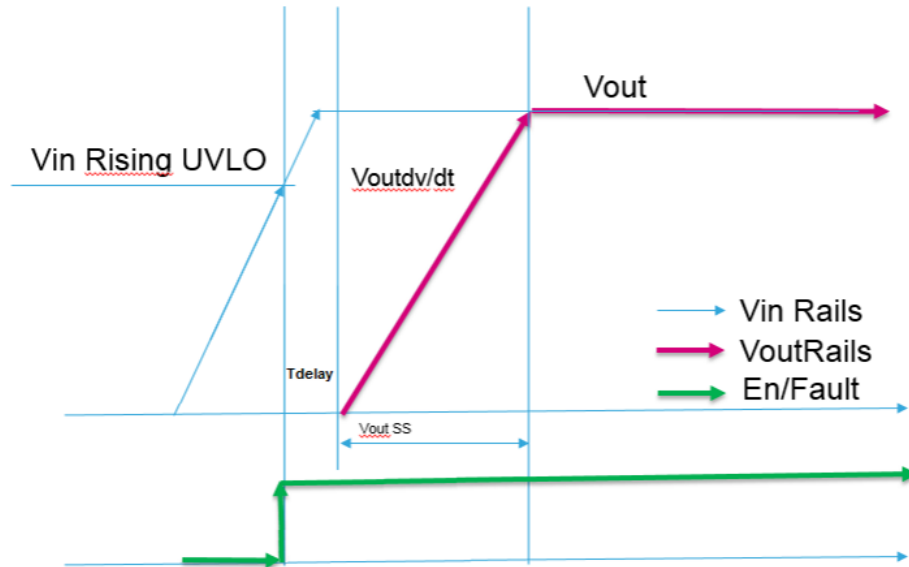

The start-up procedure starts with an initial delay time of typically **165 μ s**, then the output voltage is supplied with a slope defined by the internal dV/dt circuitry. If no additional capacitor is connected to dV/dt pin, the ramp-up time (V_{OUT} from 10% to 90%) is around **500 μ s** with $V_{IN} = 5$ V.

The inrush current profile can be controlled through a dedicated soft-start circuit. Connecting a capacitor between the $C_{dV/dt}$ pin and GND allows the modification of the output voltage ramp-up time. Given the desired time interval Δt during which the output voltage goes from 10% to 90% of V_{OUT} , the capacitance to be added on the $C_{dV/dt}$ pin can be calculated using the following theoretical formula.

$$\Delta t[ms] = 0.0024 \times V_{IN}[V] \times C_{dV/dt}[pF] + 0.1 \times V_{IN}[V] \quad (1)$$

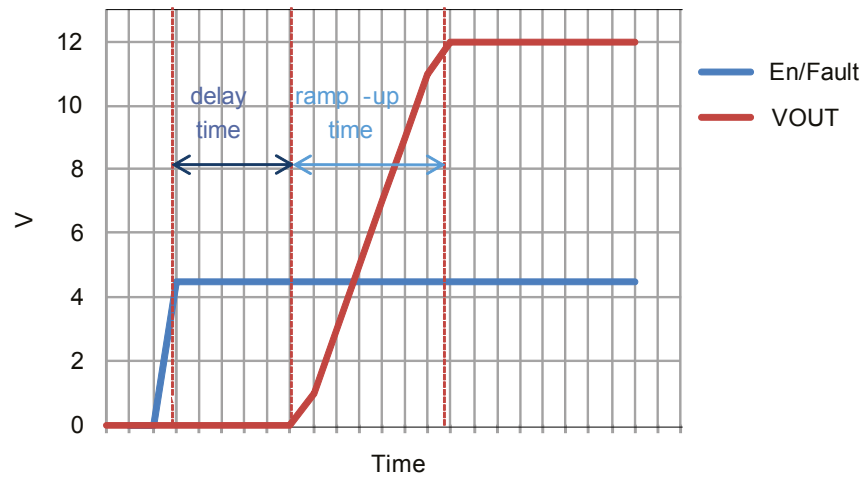
Figure 6. Delay time and V_{OUT} ramp-up time

Table 8. Rise time vs. C_{dv/dt}, V_{IN} = 5 V

C _{dv/dt} [pF]	0	22	33	47	100	180	270	470	1000
Rise time [ms]	0.5	0.76	0.89	1.06	1.7	2.66	3.74	6.14	12.5

Note: Above table shows typical rise times obtained with available capacitor values. Values with C_{dv/dt} ≠ 0 are guaranteed by design/correlation and not tested in production.

6.2 Maximum load at startup

Depending on supply voltage, load and output capacitance, it is possible that during startup the power dissipation reaches the maximum power protection and the output is shut down before the startup is completed. Increasing soft-start time, the inrush current is reduced and overtemperature fault is avoided.

Adjustable soft-start time is very useful in those applications where a single power supply serves several loads connected to the same rail with a big equivalent capacitive load. Therefore, it is important to determine the right start-up time and in-rush current to limit the dynamic power stresses and avoid thermal shutdown during startup.

6.3 Normal operating condition

The STELPD01 behaves like a power switch, buffering the circuitry on its output with the same voltage shown at its input, except for a small voltage fall due to the N-channel MOSFET R_{DSon}.

6.4 Output voltage clamp

This internal protection circuit clamps the output voltage to a maximum safe value, typically 17.5 V, if the input voltage exceeds the V_{CLAMP} threshold. In this condition, the device regulates the output voltage, therefore power dissipation increases and according to load current, the thermal shutdown can occur.

6.5 Current limiting

During operation, if the load current reaches the I_{LIM} overload threshold, an overload is detected.

The current limiting circuit opens the power MOSFET disconnecting the load.

Typical reaction time of overcurrent control loop is 1.5 μs. This time considers the delay between the instant when output current reaches I_{LIM} threshold and the activation of current control loop that acts on the gate of integrated FET to open the power path.

On the latched versions (STELPD01), the EN/Fault pin of the device is automatically set to the intermediate voltage V_{I(NT)}, during V_{out} falling edge, in order to signal the overload event to the system controller.

The device can be reset from this condition either by cycling the supply voltage or by pulling down the EN pin below the V_{IL} threshold and then releasing it.

On the auto-retry version (STELPD01A), the EN/Fault pin is pulled down and the device attempts to turn on output channel with soft-start ramp after a delay time of 100 μ s.

The R_{LIM} value for achieving the requested current limitation can be estimated by using the following table together with the graph in [Figure 9](#) and [Figure 10](#).

Table 9. I_{LIM} vs. R_{LIM}

R_{LIM} [Ω]	15	22	36	39	51	75	120	220	300
I_{LIM} [A]	6.45	5.15	3.9	3.55	3	2.4	2.1	1.55	1.4

Note: Missing or shorted R_{LIM} causes current limit circuit malfunction and may lead to device damage.

Note: R_{LIM} value higher than 300 Ω can be used but as shown in [Figure 9](#) the I_{LIM} vs. R_{LIM} relationships is flat.

6.6 Thermal shutdown function

If the device temperature exceeds the thermal shutdown threshold (T_{SHDN}), typically 165 $^{\circ}$ C, the power MOSFET is turned off and the load is disconnected.

On the latched version (STELPD01), the EN/Fault pin of the device is automatically set to the intermediate voltage $V_{I(INT)}$, in order to signal the overtemperature event to the system controller.

The device can be reset from this condition either by cycling the supply voltage or by pulling down the EN pin below the V_{IL} threshold and then releasing it.

On the auto-retry version (STELPD01A), the EN/Fault pin is set low, and the auto-retry circuit attempts to restart the device with soft-start ramp once the die temperature is reduced to 145 $^{\circ}$ C typ. (165 $^{\circ}$ C minus the hysteresis value, 20 $^{\circ}$ C typ.).

6.7 EN/Fault pin

The EN/Fault pin has the dual function of controlling the output of the device and providing information about the device status to the application.

When it is used as a standard Enable pin, it can be connected to an external open-drain or open-collector device. In this case, when it is pulled at low logic level, the device turns the output off, when it is left floating the device turns on the output, since it has internal pull-up circuitry.

In case of a fault, on the latched versions, this pin is set to the intermediate voltage $V_{I(INT)}$, this signal can be provided to a monitor circuit, informing it that a fault event has occurred or it can be directly connected to the EN/Fault pins of other devices of the same family on the same application in order to achieve a simultaneous enable/disable feature. In case of UVLO event ($V_{IN} = V_{UVLO} - V_{hyst}$) an internal pull-down block is activated in order to keep the device in off-state.

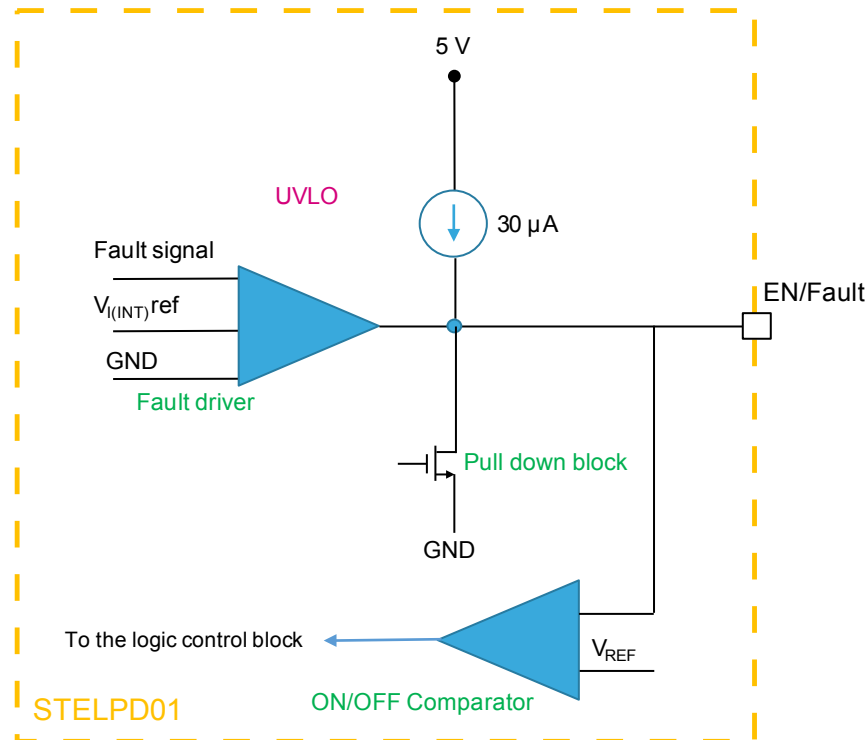
Figure 7. EN/Fault driver circuit

6.8 External gate driver function for reverse blocking

The STELPD01 provides a dedicated gate drive signal on the VG pin which can be used to control an external blocking MOSFET for reverse-current protection (RCP). See [Figure 4](#).

When the internal control circuitry is enabled to perform output start-up ramp, the V_{gate} pin is pulled up by External FET charging current I_{FET} to the charge pump voltage referred to the V_{in} voltage in order to guarantee the activation of external FET.

If the input voltage reaches V_{clamp} threshold the V_{gate} voltage is also clamped to a safe value of $V_{out} + 5.5$ V. See [Figure 23](#).

Reverse current protection is activated in case V_{IN} falls below the undervoltage lockout (UVLO), the enable (EN) voltage falls below the low-level threshold, or a fault event occurs.

For example, as V_{CC} drops during input power removal, the device turn off internal FET and it sinks current from the gate of the external FET to quickly turn it off, therefore blocking any current flow from the load to the input side.

Figure 8. External gate driver circuit

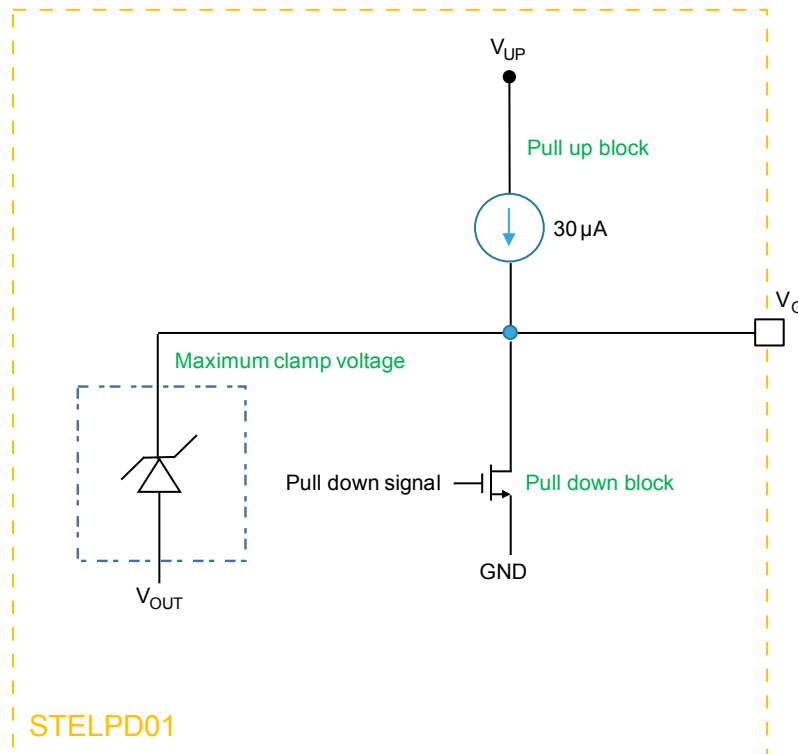

6.9 External capacitors and application guidelines

Input and output capacitors are mandatory to guarantee device control loop stability and reduce the transient effects of stray inductances which may be present on the input and output power paths. In fact, when the STELPD01 interrupts the current flow, input inductance generates a positive voltage spike on the input, and output inductance generates a negative voltage spike on the output. To reduce the effects of such transients, a C_{IN} capacitor of at least $1 \mu\text{F}$ must be connected between the input pin and GND, and located as close as possible to the device.

For the same reason, a C_{OUT} capacitor of at least $1 \mu\text{F}$ must be connected at the output port.

When the device is powered by a power line made up of very long wires, where input inductance is higher than $1 \mu\text{H}$, the input capacitor should be increased.

It is recommended to provide for additional protections and methods for addressing these transients, such as:

- Minimizing inductance of the input and output tracks
- TVS diodes on the input to absorb inductive spikes
- Schottky diode on the output to absorb negative spikes
- Combination of ceramic and electrolytic capacitors on the input and output

7 Typical characteristics

$V_{IN} = 5\text{ V}$, $V_{EN/Fault} = \text{floating}$, $R_{LIM} = 51\ \Omega$, $C_{IN} = 2.2\ \mu\text{F}$, $C_{OUT} = 10\ \mu\text{F}$, $C_{dV/dt} = 560\ \text{pF}$, $T_A = 25\ ^\circ\text{C}$, unless otherwise specified.

Figure 9. I_{LIM} vs. R_{LIM}

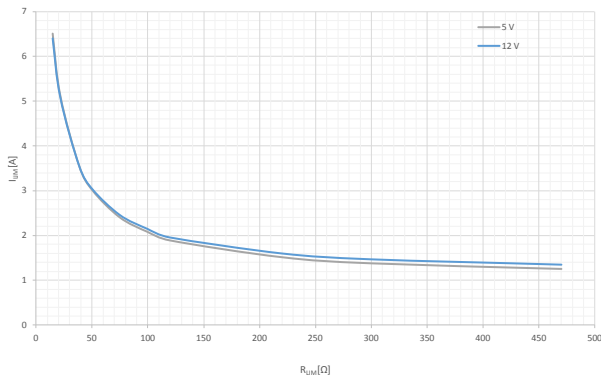

Figure 10. I_{LIM} vs. R_{LIM} (magnification)

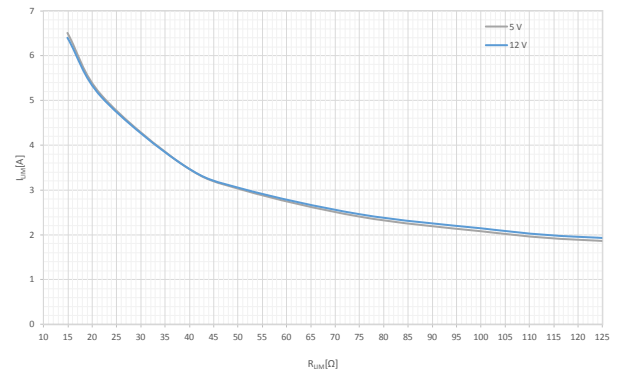

Figure 11. Bias current vs. temperature (ON Mode)

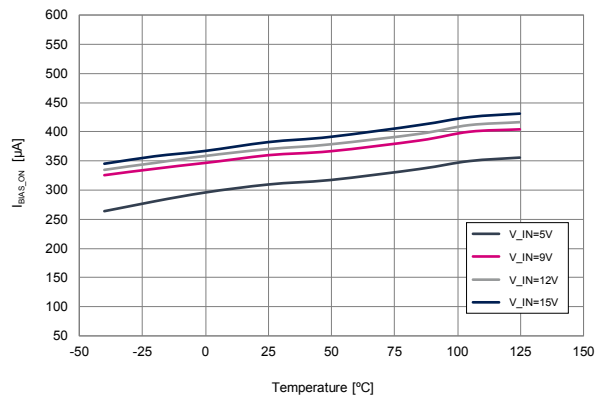

Figure 12. Bias current vs. temperature (Fault Mode)

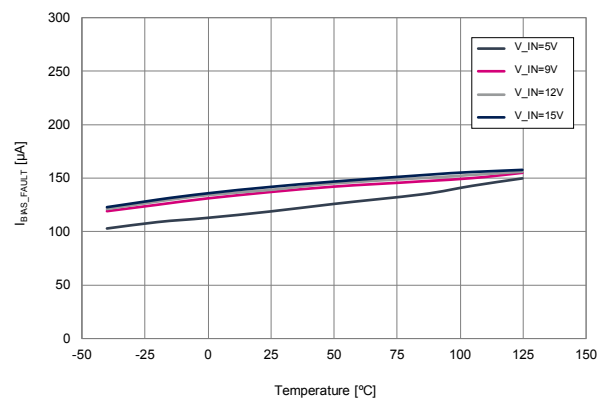

Figure 13. Bias current vs. temperature (OFF Mode)

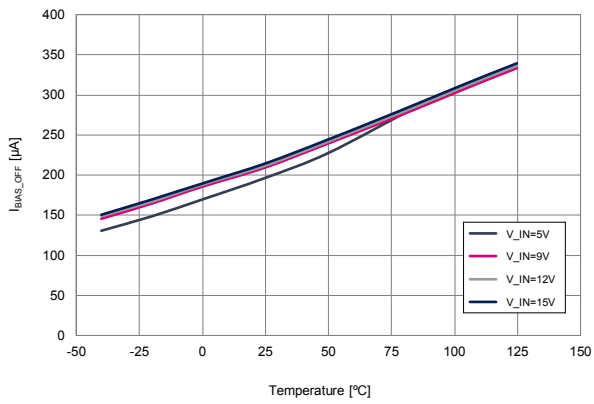

Figure 14. R_DS_ON vs. temperature

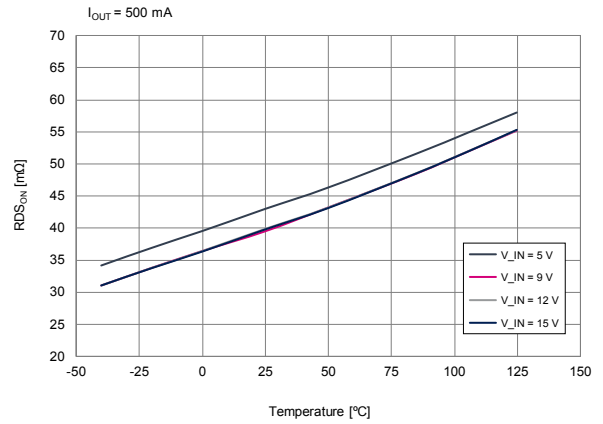

Figure 15. I_LIM vs. temperature

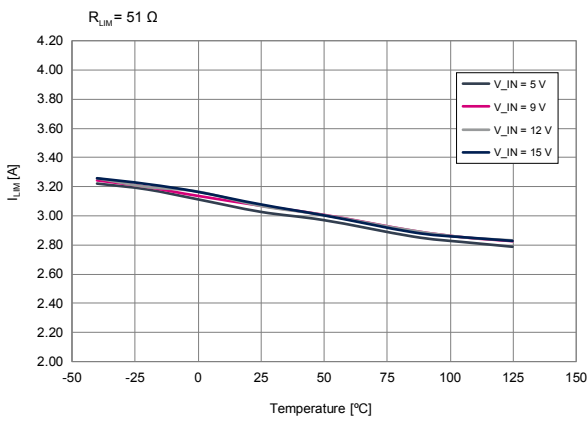

Figure 16. Clamping voltage vs. temperature

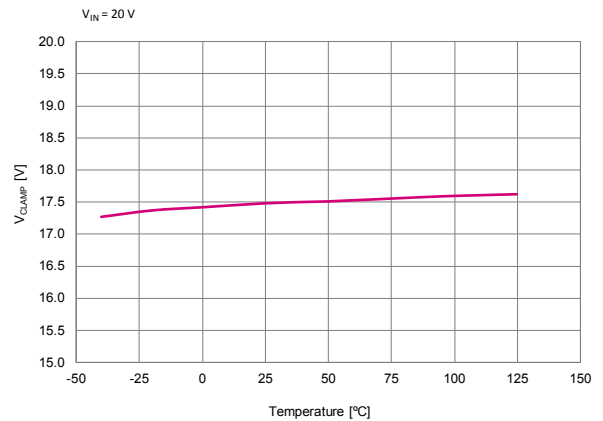

Figure 17. UVLO vs. temperature

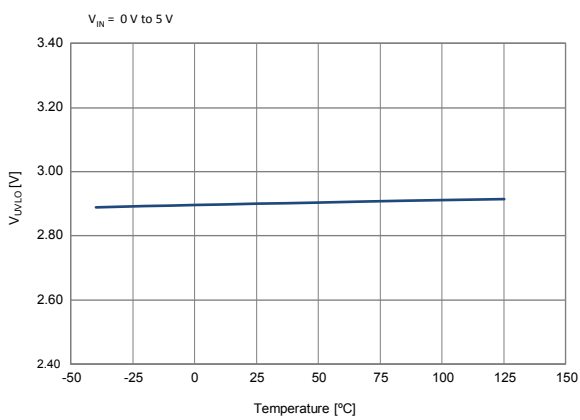

Figure 18. UVLO Hysteresis vs. temperature

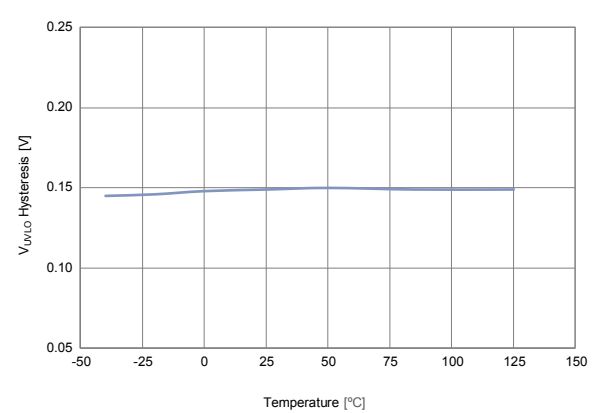

Figure 19. EN/Fault pin thresholds vs. temperature

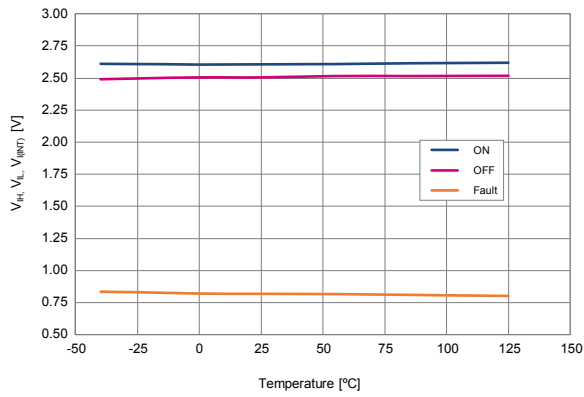

Figure 20. EN/Fault pull-up voltage vs. temperature

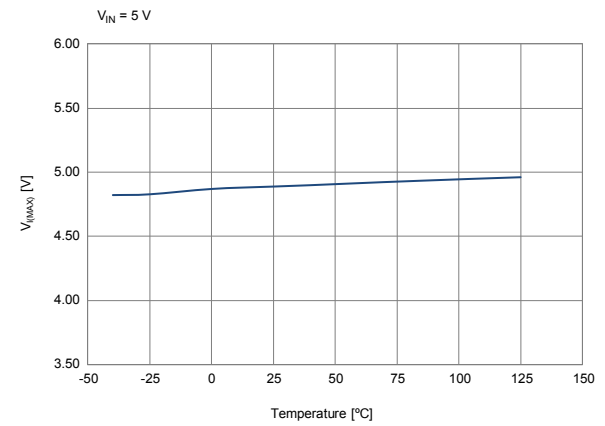

Figure 21. EN/Fault pin current vs. temperature (EN/Fault to GND)

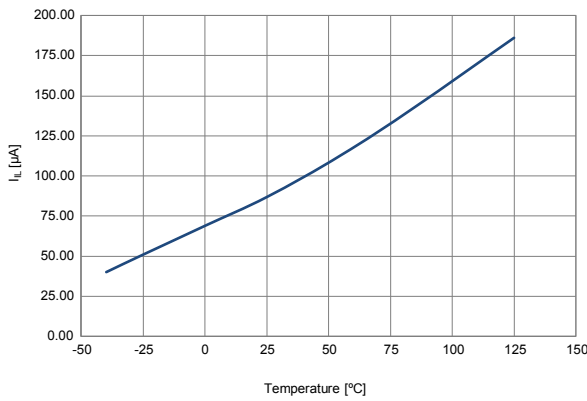

Figure 22. Soft-start time vs. temperature (no Cdv/dt)

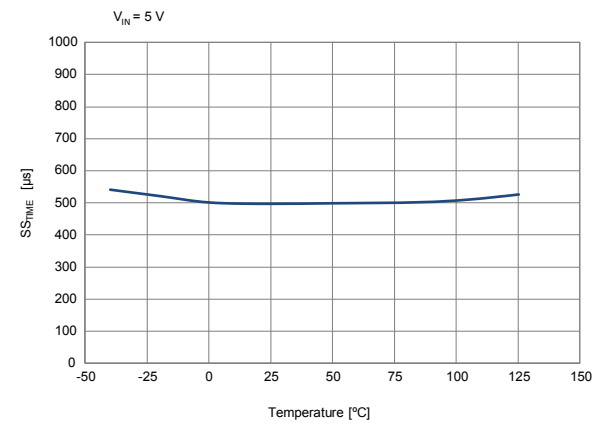

Figure 23. External FET clamp voltage (V_{FETmax}) vs. input voltage

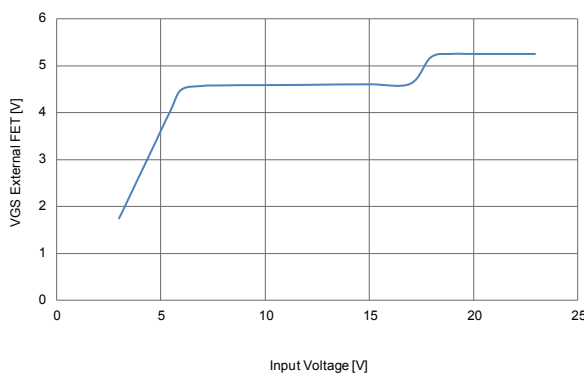
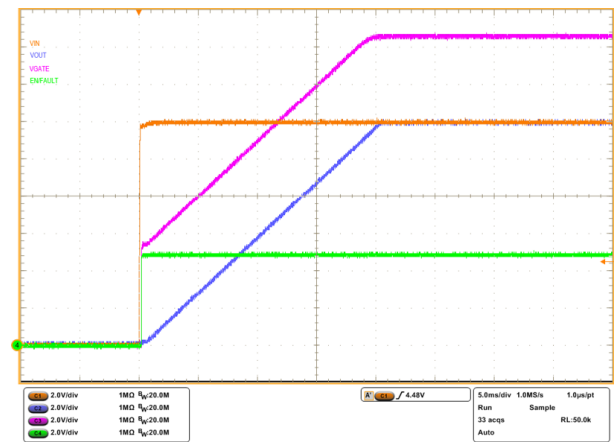

Figure 24. Startup with no load



V_{IN} = from 0 V to 12 V (Hot-plug connection), I_{OUT} = 0 mA

Figure 25. Startup with $R_{LOAD} = 5 \Omega$

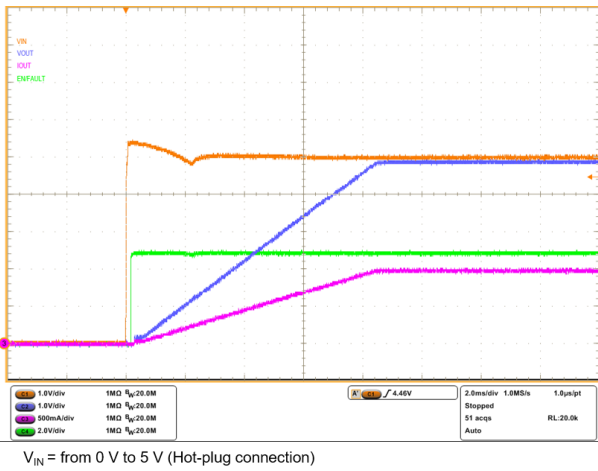

Figure 26. Startup into voltage clamp

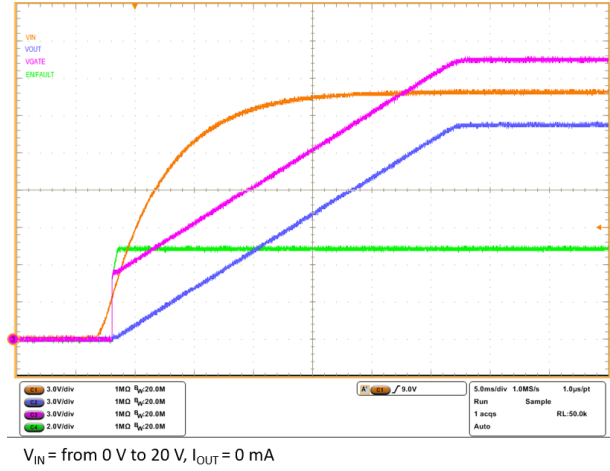

Figure 27. Voltage clamp during operation

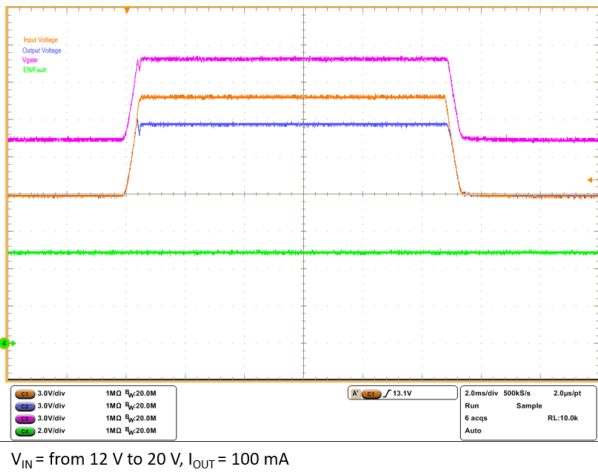

Figure 28. Start-up into output short-circuit

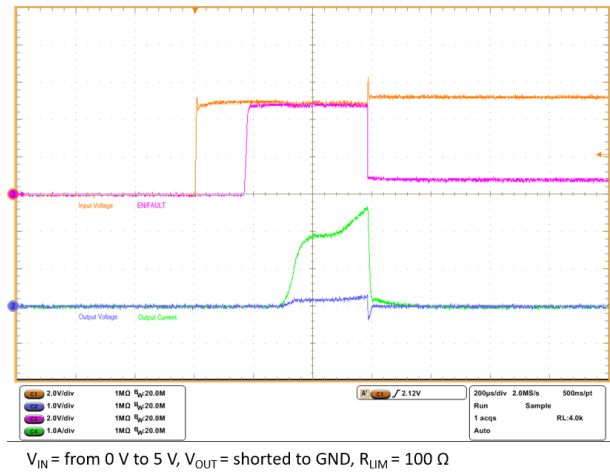

Figure 29. Startup into overload

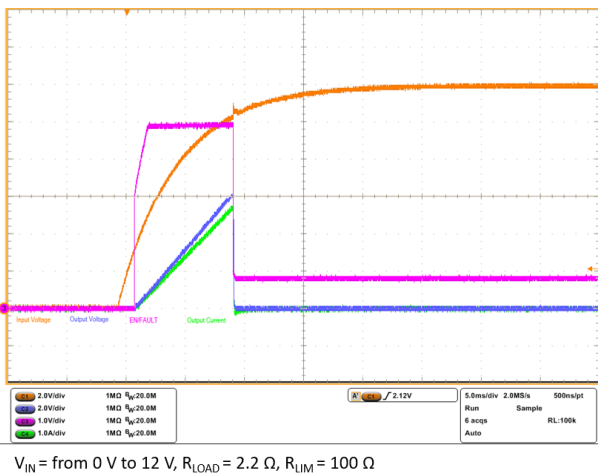

Figure 30. Overcurrent protection during operation (latched version)

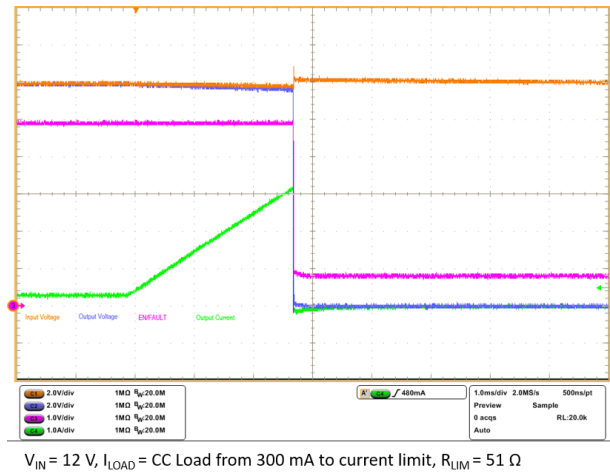
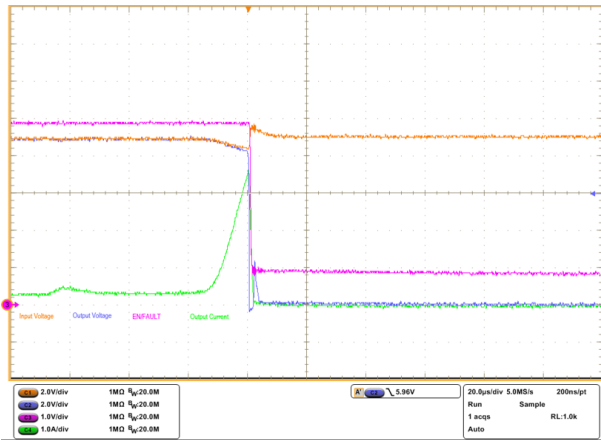
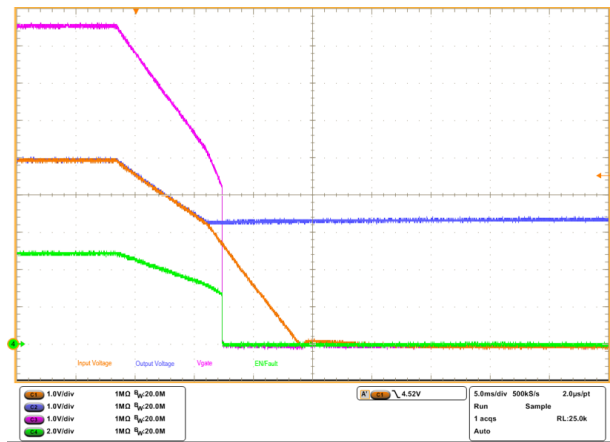

Figure 31. Output short-circuit during operation (latched version)



$V_{IN} = 9\text{ V}$, $I_{LOAD} = \text{CC Load from } 300\text{ mA to short circuit}$, $R_{LIM} = 51\ \Omega$

Figure 32. Power loss protection through UVLO



$V_{IN} = \text{from } 5\text{ V to floating}$, $I_{OUT} = 0\text{ mA}$, $C_{OUT} = 100\ \mu\text{F}$

Figure 33. Power loss protection through EN/Fault

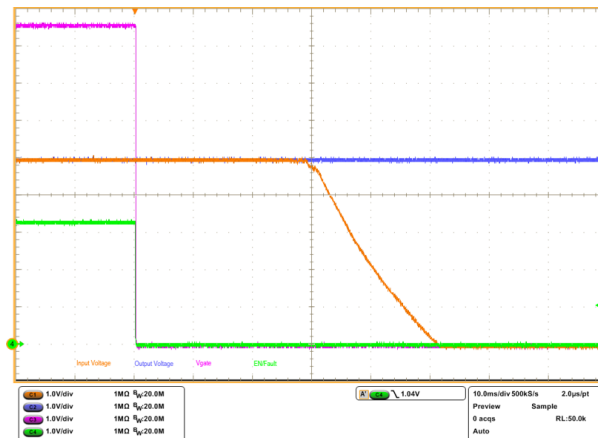

$V_{IN} = \text{from } 5\text{ V to } 0\text{ V}$, $V_{EN/Fault} = \text{from } 3.3\text{ V to GND}$, $I_{OUT} = 0\text{ mA}$, $C_{OUT} = 100\ \mu\text{F}$

8 Package information

In order to meet environmental requirements, ST offers these devices in different grades of **ECOPACK** packages, depending on their level of environmental compliance. ECOPACK specifications, grade definitions and product status are available at: www.st.com. ECOPACK is an ST trademark.

8.1 DFN10L (3x3 mm) package information

Figure 34. DFN10L (3x3 mm) package outline

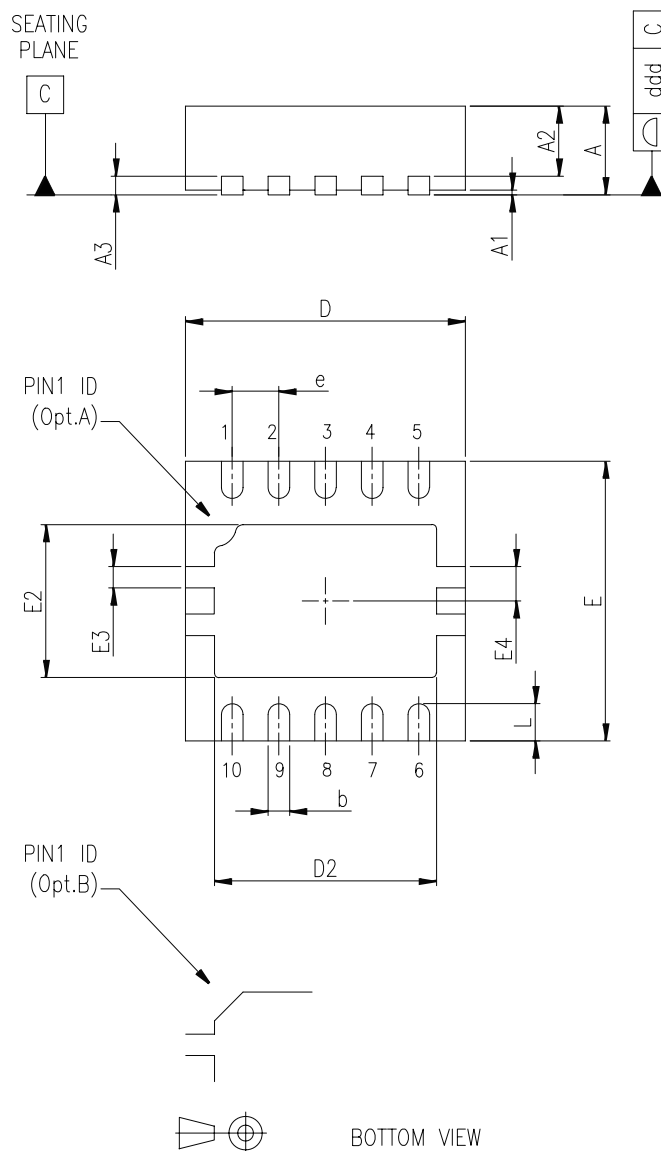

Table 10. DFN10L (3x3 mm) mechanical data

Dim.	mm		
	Min.	Typ.	Max.
A	0.80	0.90	1.00
A1		0.02	0.05
A2	0.55	0.65	0.80
A3		0.20	
b	0.18	0.25	0.30
D	2.85	3.00	3.15
D2	2.20		2.70
E	2.85	3.00	3.15
E2	1.40		1.75
E3	0.230		
E4	0.365		
e		0.50	
L	0.30	0.40	0.50
ddd			0.08

Figure 35. DFN10L (3x3 mm) recommended footprint

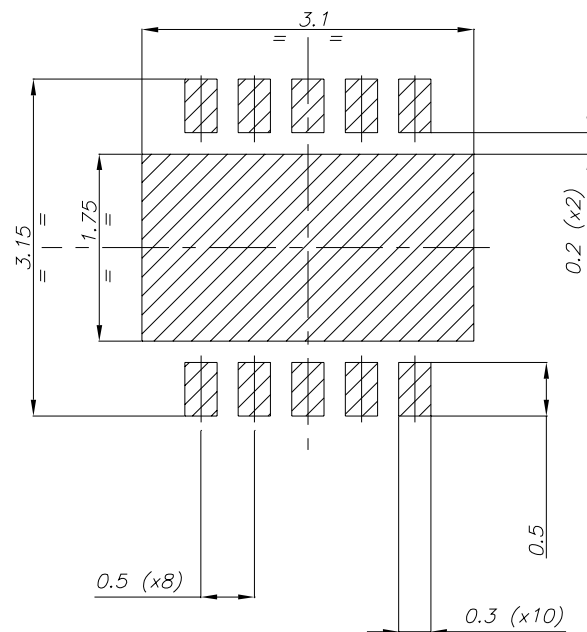

Figure 37. DFN10 (3 x 3 mm) carrier tape

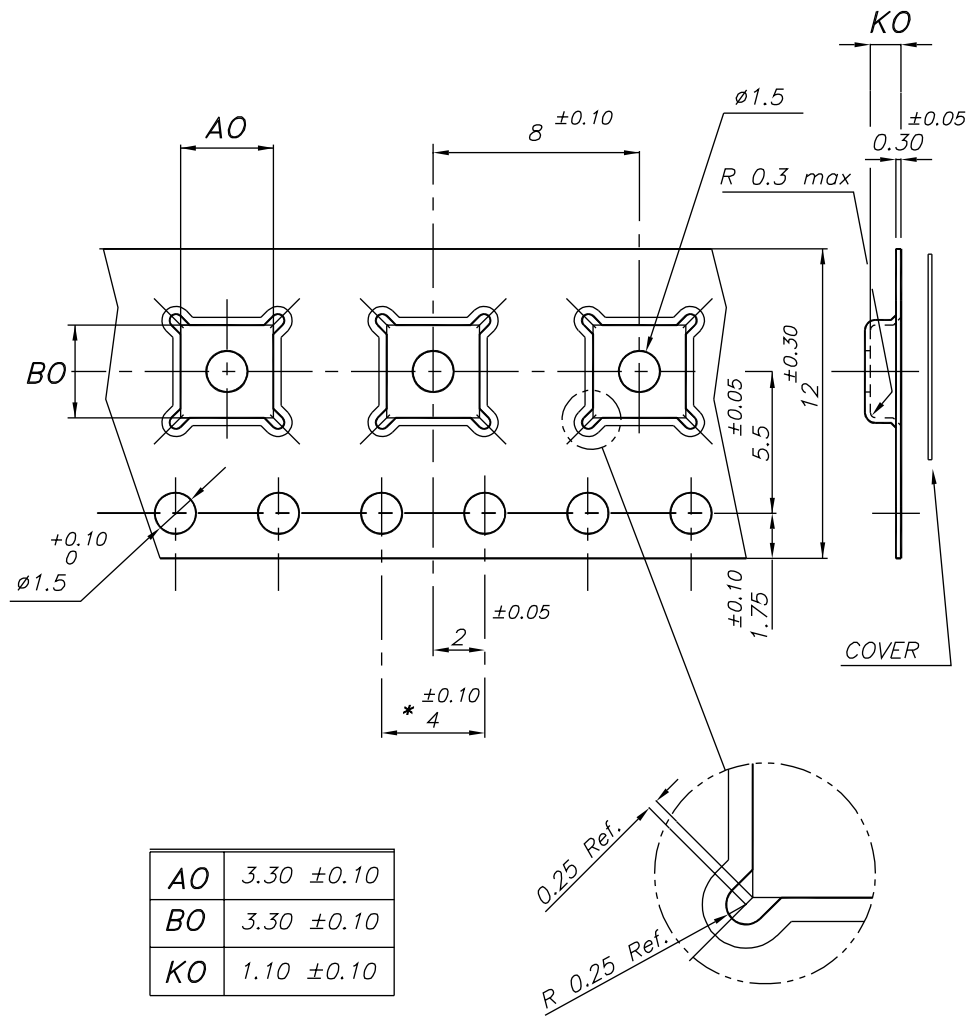
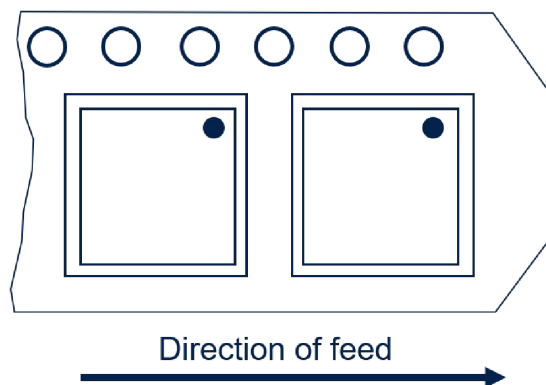

Figure 38. DFN10 (3 x 3 mm) device orientation in tape



9 Ordering information

Table 11. Order codes

Order code	Package	Packaging	Marking	Response to thermal and overcurrent fault	EN/Fault at startup
STELPD01PUR	DFN10L-(3x3 mm)	Tape and reel	EPD1	Latch-off	High (Automatic startup)
STELPD01APUR ⁽¹⁾			TBD	Auto-retry	

1. Version under development. Contact ST sales offices.

Revision history

Table 12. Document revision history

Date	Revision	Changes
17-Jan-2022	1	Initial release.

Contents

1	Diagram	2
2	Pin configuration	3
3	Application circuits	4
4	Maximum ratings	5
5	Electrical characteristics	6
6	Functional description	8
6.1	Turn-on and soft start-up feature	8
6.2	Maximum load at startup	9
6.3	Normal operating condition	9
6.4	Output voltage clamp	9
6.5	Current limiting	9
6.6	Thermal shutdown function	10
6.7	EN/Fault pin	10
6.8	External gate driver function for reverse blocking	11
6.9	External capacitors and application guidelines	12
7	Typical characteristics	13
8	Package information	18
8.1	DFN10L (3x3 mm) package information	18
8.2	DFN10 (3 x 3 mm) packing information	20
9	Ordering information	22
	Revision history	23

List of tables

Table 1.	Pin description	3
Table 2.	Typical application components	4
Table 3.	Absolute maximum ratings	5
Table 4.	Thermal data	5
Table 5.	ESD performance	5
Table 6.	Recommended operating condition	5
Table 7.	Electrical characteristics	6
Table 8.	Rise time vs. $C_{dV/dt}$, $V_{IN} = 5\text{ V}$	9
Table 9.	I_{LIM} vs. R_{LIM}	10
Table 10.	DFN10L (3x3 mm) mechanical data	19
Table 11.	Order codes	22
Table 12.	Document revision history	23

List of figures

Figure 1.	Block diagram	2
Figure 2.	Pin connection (top view)	3
Figure 3.	Typical application circuit	4
Figure 4.	Typical application circuit with reverse current protection	4
Figure 5.	Typical startup sequence for STELPD01 and STELPD01A	8
Figure 6.	Delay time and V_{OUT} ramp-up time	9
Figure 7.	EN/Fault driver circuit	11
Figure 8.	External gate driver circuit	12
Figure 9.	I_{LIM} vs. R_{LIM}	13
Figure 10.	I_{LIM} vs. R_{LIM} (magnification)	13
Figure 11.	Bias current vs. temperature (ON Mode)	13
Figure 12.	Bias current vs. temperature (Fault Mode)	13
Figure 13.	Bias current vs. temperature (OFF Mode)	14
Figure 14.	R_{DS_ON} vs. temperature.	14
Figure 15.	I_{LIM} vs. temperature	14
Figure 16.	Clamping voltage vs. temperature	14
Figure 17.	UVLO vs. temperature	14
Figure 18.	UVLO Hysteresis vs. temperature	14
Figure 19.	EN/Fault pin thresholds vs. temperature.	15
Figure 20.	EN/Fault pull-up voltage vs. temperature	15
Figure 21.	EN/Fault pin current vs. temperature (EN/Fault to GND).	15
Figure 22.	Soft-start time vs. temperature (no C_{dv}/dt)	15
Figure 23.	External FET clamp voltage (V_{FETmax}) vs. input voltage	15
Figure 24.	Startup with no load	15
Figure 25.	Startup with $R_{LOAD} = 5 \Omega$	16
Figure 26.	Startup into voltage clamp	16
Figure 27.	Voltage clamp during operation.	16
Figure 28.	Start-up into output short-circuit	16
Figure 29.	Startup into overload	16
Figure 30.	Overcurrent protection during operation (latched version).	16
Figure 31.	Output short-circuit during operation (latched version)	17
Figure 32.	Power loss protection through UVLO	17
Figure 33.	Power loss protection through EN/Fault	17
Figure 34.	DFN10L (3x3 mm) package outline	18
Figure 35.	DFN10L (3x3 mm) recommended footprint.	19
Figure 36.	DFN10 (3 x 3 mm) reel drawing outline	20
Figure 37.	DFN10 (3 x 3 mm) carrier tape	21
Figure 38.	DFN10 (3 x 3 mm) device orientation in tape	21

IMPORTANT NOTICE – PLEASE READ CAREFULLY

STMicroelectronics NV and its subsidiaries (“ST”) reserve the right to make changes, corrections, enhancements, modifications, and improvements to ST products and/or to this document at any time without notice. Purchasers should obtain the latest relevant information on ST products before placing orders. ST products are sold pursuant to ST’s terms and conditions of sale in place at the time of order acknowledgement.

Purchasers are solely responsible for the choice, selection, and use of ST products and ST assumes no liability for application assistance or the design of Purchasers’ products.

No license, express or implied, to any intellectual property right is granted by ST herein.

Resale of ST products with provisions different from the information set forth herein shall void any warranty granted by ST for such product.

ST and the ST logo are trademarks of ST. For additional information about ST trademarks, please refer to www.st.com/trademarks. All other product or service names are the property of their respective owners.

Information in this document supersedes and replaces information previously supplied in any prior versions of this document.

© 2022 STMicroelectronics – All rights reserved