

Self Test Ground Fault Circuit Interrupter (GFCI)

NCS37014

The NCS37014 is a UL943 compliant signal processor for GFCI applications with self test. The device integrates a flexible power supply (including a 12 V shunt and two 3.3 V internal series regulators), differential fault, and grounded-neutral detection circuits. Self test is monitored at start up and then every 17 minutes.

Features

- Meets UL943 Self-test GFCI Requirements
- 4.0 – 12 Volt Operation (120–480 V AC mains with the appropriate series impedance)
- –40°C to 95°C
- Typical 575 μ A Quiescent Current @ 11 V
- 16 Pin QFN
- Self Syncing Internal Oscillator adjusts to AC Mains Frequency to Guarantee Full Resolution on 60 Hz Distribution Systems
- Optimized Solenoid Deployment (coil is not energized near the AC mains zero crossings).
- Power Supply Monitor that Verifies Full Diode Bridge Operation
- Tiered Trip Times that Increase Immunity to Noise
- Under-voltage Detection that Allows for Increased Operation at Lower AC Input Voltages

Typical Applications

- GFCI Receptacles
- Load Panel GFCI Breakers
- In-line GFCI Circuits (power cords)



1

QFN16
 CASE 485FQ

PIN ASSIGNMENT

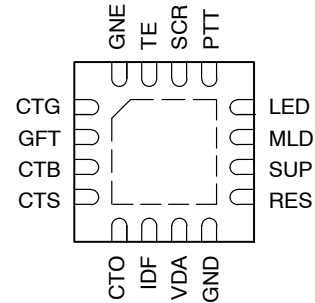

(Top View)

MARKING DIAGRAM

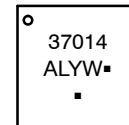

- 37014 = Specific Device Code
- A = Assembly Location
- L = Wafer Lot
- Y = Year
- W = Work Week
- = Pb-Free Package

(Note: Device NCS37014MNTWG includes Pb-Free micro dot below assembly information text; Device NCS37014MNATWG includes Pb-Free micro dot to the right of assembly information text)

ORDERING INFORMATION

See detailed ordering and shipping information on page 7 of this data sheet.

NCS37014

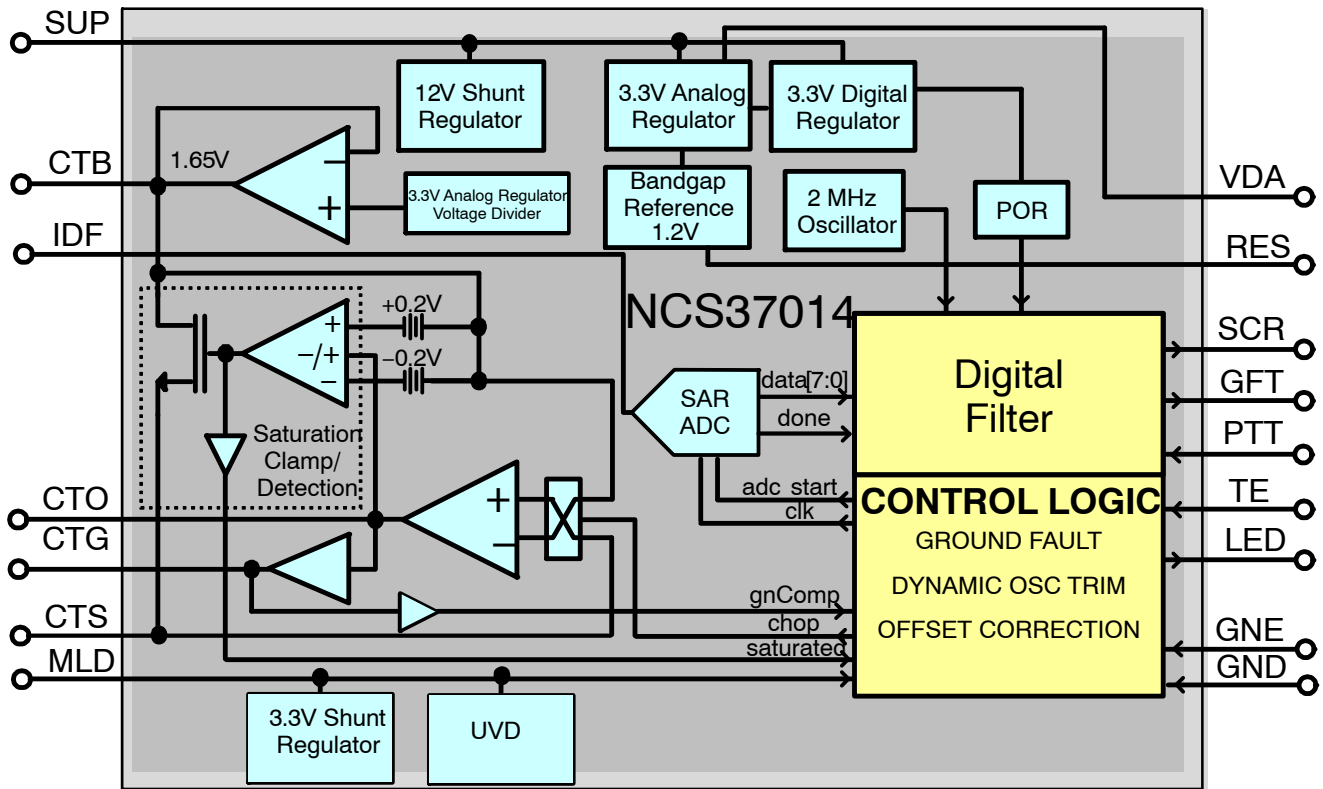

Figure 1. Simplified Block Diagram

Table 1. QFN PIN DESCRIPTION

Pin #	Name	Pad Description
1	CTG	Ground Neutral current transformer stimulus
2	GFT	Differential self test output signal
3	CTB	Differential current transformer bias voltage
4	CTS	Differential current input
5	CTO	Differential current to voltage output
6	IDF	Differential low pass filter/ADC input
7	VDA	Analog 3.3 V regulator output/ ADC reference voltage
8	GND	Electronics ground
9	RES	Reference current bias input
10	SUP	Power supply input
11	MLD	Mains level/under voltage detector
12	LED	End of life LED drive
13	PTT	Push to test input
14	SCR	SCR gate drive signal
15	TE	Test enable
16	GNE	Ground-neutral enable input

Table 2. ABSOLUTE MAXIMUM RATINGS

Rating	Symbol	Value	Unit
Supply Voltage Range	V _s	13.5	V
Supply Current	I _s	10	mA
Input Voltage Range (Note 3)	V _{in}	-0.3 to 3.6	V
Output Voltage Range	V _{out}	-0.3 to 3.6 V or (V _{in} + 0.3), whichever is lower	V
Maximum Junction Temperature	T _{J(max)}	140	°C
Storage Temperature Range	T _{STG}	-65 to 150	°C
ESD Capability, Human Body Model (Note 4)	ESD _{HBM}	2	kV
ESD Capability, Charge Device Model (Note 4)	ESD _{CDM}	500	V
Lead Temperature Soldering Reflow (SMD Styles Only), Pb-Free Versions (Note 5)	T _{SLD}	260	°C

Stresses exceeding those listed in the Maximum Ratings table may damage the device. If any of these limits are exceeded, device functionality should not be assumed, damage may occur and reliability may be affected.

1. Functional operation above the Recommended Operating Conditions is not implied. Extended
2. Exposure to stresses above the Recommended Operating Conditions may affect device reliability.
3. Refer to ELECTRICAL CHARACTERISTICS and APPLICATION INFORMATION for Safe Operating Area.
4. This device series incorporates ESD protection and is tested by the following methods:
 ESD Human Body Model tested per JS-001-2012
 ESD Charge Device Model tested per JESD22-C101-F
 Latchup Current Maximum Rating: ≤ 100 mA per JEDEC standard: JESD78D
5. For information, please refer to our Soldering and Mounting Techniques Reference Manual, SOLDERM/D

Table 3. THERMAL CHARACTERISTICS

Rating	Symbol	Value	Unit
Thermal Characteristics, QFN16, 3x3.3 mm (Note 6) Thermal Resistance, Junction-to-Air (Note 7)	R _{θJA}	64	°C/W

6. Refer to ELECTRICAL CHARACTERISTICS and APPLICATION INFORMATION for Safe Operating Area.
7. Values based on copper area of 645 mm² (or 1 in²) of 1 oz copper thickness and FR4 PCB substrate.

NCS37014

Table 4. OPERATING RANGES (Unless otherwise noted, $I_{SUP} = 3 \text{ mA}$, MLD input = 60 Hz, Refer to Figure 2)

Parameter	Conditions	Min	Typ	Max	Units
Operating Temperature	Ambient	-40		95	C
Shunt Regulator Voltage	SUP to GND, $I_{SUP} = 1 \text{ mA}$		12	13	V
Shunt Regulator Current	I_{SUP}			10	mA
Quiescent Current	I_{SUP} , SUP = 10.5 V		575	750	μA
RMS Trip Threshold Voltage	IDF to CTB, $R_8 = 32 \text{ k}\Omega$, $R_{CTO} = 500 \Omega$	191	203	215	mV
SCR Trigger Current	I_{SCR} , SCR = 1 V, $I_{SHUNT} < 6 \text{ mA}$	4			mA
SCR Trigger Output Voltage	SCR to GND, SUP < 4 V	3		3.6	V
LED Output Voltage	LED to GND, SUP < 4 V	3		3.6	V
CTB Bias Voltage	CTB to GND, VDA = 3.3 V		1.65		V
CTS-CTB Absolute Offset Voltage	CTS-CTB	-250		250	μV
Fault Response Time	$6 \text{ mA} \leq I_{DIFF} < 10 \text{ mA}$			125	ms
Fault Response Time	$10 \text{ mA} \leq I_{DIFF} < 15 \text{ mA}$			95	ms
Fault Response Time	$15 \text{ mA} \leq I_{DIFF} < 17.5 \text{ mA}$			75	ms
Fault Response Time	$17.5 \text{ mA} \leq I_{DIFF} < 20 \text{ mA}$			60	ms
Fault Response Time	$20 \text{ mA} \leq I_{DIFF} < 22.5 \text{ mA}$			50	ms
Fault Response Time	$22.5 \text{ mA} \leq I_{DIFF} < 26.5 \text{ mA}$			40	ms
Fault Response Time	$26.5 \text{ mA} \leq I_{DIFF} < 29 \text{ mA}$			35	ms
Fault Response Time	$29 \text{ mA} \leq I_{DIFF} < 33 \text{ mA}$			25	ms
Fault Response Time	$I_{DIFF} \geq 33 \text{ mA}$			20	ms
CTG Comparator Threshold	CTG to GND, VDA = 3.3 V		1.95		V
CTG Timer	CTG > Threshold		45		μs
CTG GN Trip Frequency	CTG to GND	2		7	kHz
GN Response Time	Continuous GN Fault			350	ms
Internal Oscillator Frequency	$F_{AC} = 60 \text{ Hz} \pm 0.1$	1.8	2	2.2	MHz
Under Voltage Detect	V_{AC} to GND, $R_7 = 1 \text{ M}\Omega$, $\pm 1\%$	80	87	95	V _{rms}
MLD Max Clamp Current	I_{MLD} Max Sink Current			400	μA
MLD Pull Down Current	MLD = 1 V		500		nA
First ST Timer	VDA > 3 V	1.7	2	2.3	seconds
Periodic ST Timer, Pass	Steady State, ST Pass	15	17	20	minutes
Periodic ST Timer, Fail	ST Fail	0.8	1	1.2	minutes
Consecutive ST Failure Timer	ST Fail Counter, Enable SCR		7		
LED Blink Frequency	First ST Failure	1.8	2	2.2	Hz
ST Cycle GF Pass Window	I_{DIFF} Ground Fault	6		14	mA
MLD Pin Check Wait Time to Enable LED	No MLD signal		500		ms
MLD Pin Continuity Pass	Input Frequency	25			Hz
LED Blink Frequency	No MLD signal	1.5	2	2.5	Hz
MLD Pin Check Wait Time to Enable SCR	No MLD signal		6		minutes

Functional operation above the stresses listed in the Recommended Operating Ranges is not implied. Extended exposure to stresses beyond the Recommended Operating Ranges limits may affect device reliability.

8. Refer to ELECTRICAL CHARACTERISTICS and APPLICATION INFORMATION for Safe Operating Area.

APPLICATIONS INFORMATION

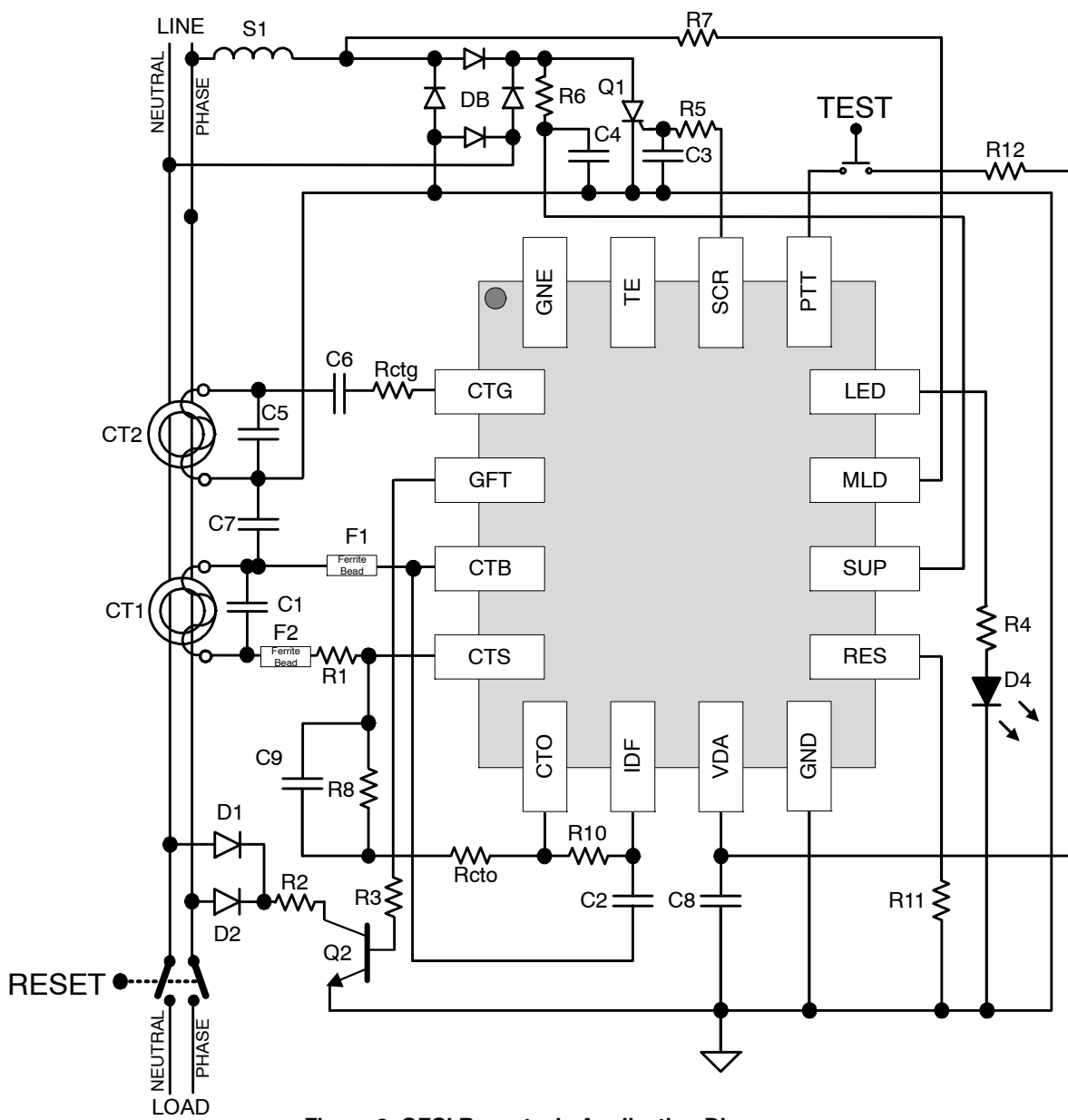

Figure 2. GFCI Receptacle Application Diagram

Table 5. RECOMMENDED EXTERNAL COMPONENTS

Component Type	Instance	Value	Note
SCR	Q1	–	ON–MCR08
NPN	Q2	–	MMBT6517LT1–D
Diode Bridge	DB	–	
Diode	D1, D2	–	1N4007
Diode	D3	–	1N4007, auxiliary supply
LED	D4	–	LED for self test failure
Capacitor	C1	33 nF	Differential current filter capacitor
Capacitor	C2	56 nF	Anti–aliasing filter (1 kHz corner frequency)
Capacitor	C3	10 nF	SCR gate filter capacitor
Capacitor	C4	1 μ F	SUP pin holding capacitor
Capacitor	C5	22–220 pF	Ground Neutral CT resonance capacitor
Capacitor	C6	4.7–47 nF	Ground Neutral CT AC coupler
Capacitor	C7	1 nF	CTB bias filter
Capacitor	C8	1 μ F	Analog 3.3 V regulator filter
Capacitor	C9	1 nF	High frequency filter
Resistor	R1	243 Ω	Precision resistor (1%), Differential burden/CT low pass filter
Resistor	R2	15 k Ω	Controls the self test current in the Q2
Resistor	R3	10 k Ω	Sets the current in the base of Q2
Resistor	R4	6.8 k Ω	Limits current to the LED D3
Resistor	R5	0.47–4.7 k Ω	Sets allowable gate current in Q1
Resistor	R6	72 k Ω	Power supply current limit
Resistor	R7	1 M Ω	MLD current limit/under voltage attenuator
Resistor	R8	32 k Ω	Precision resistor (1%), Sets the differential trip level at 5 mA _{RMS}
Resistor	R9	72 k Ω	Power supply current limit
Resistor	R10	10–20 k Ω	Differential filter resistor
Resistor	R11	120 k Ω	Precision resistor (1%), Current reference bias resistor
Resistor	R12	10 k Ω	Test button pull–up resistor
Resistor	Rcto	0.47–1.5 k Ω	Precision resistor (1%), Sets the differential trip level at 5 mA _{RMS}
Resistor	Rctg	0 – 200 Ω	Sets the GN sensitivity
Current Transformer	CT1	800	Differential current transformer
Current Transformer	CT2	250	GN current transformer

Functional Description (refer to application circuit)

The NCS37014 provides for a single IC controller solution for ground fault, grounded neutral and self–test protection per UL standard UL943.

The key internal blocks include: 12 V shunt regulator, precision bandgap reference, two 3.3 V linear regulators (one for the digital and one for the analog circuit) sense amplifier with V_{OS} cancellation, 1.65 V reference for the CT, 2 MHz oscillator dynamically trimmed to the AC line frequency, 8 bit SAR ADC, comparators, digital filters and digital control logic.

The internal shunt regulator clamps the SUP pin voltage at 12 volts. This provides the bias voltage for the analog

(vda) and digital (vdd) internal circuitry via two 3.3 V linear regulators.

At POR detection ($v_{da} > 2.475$) the logic is reset and the bias circuitry is enabled, the LED pin will blink once for 250 ms. The MLD pin is continually checked for an input signal greater than 25 Hz. If the MLD signal is greater than 25 Hz, this test passes. If it fails, the LED blinking logic will be enabled. A six minute timer will start and if no MLD signal is detected, the SCR will be enabled. If a MLD signal occurs before the six minute timer and is longer than one minute, the timer will be reset.

The first self test (ST) cycle will occur at two seconds and thereafter every 17 minutes. During the ST cycle the GFT

pin will be enabled and the CT current (set at 8 mA, R2) will be verified for two half cycles. If a ST cycle fails due to a low GF detection or a GF signal greater than 30 mA, the LED blinking logic will be enabled. Another ST cycle will occur in one minute. If seven consecutive ST cycles fail the SCR will be enabled. If a ST cycle passes before the 7 consecutive cycle counter, the ST logic will be reset and a ST cycle will occur in 17 minutes.

The CT is biased at 1.65 volts. The sense amplifier monitors the ground fault current. This current is converted to a voltage level at the CTO pin which is the input to the ADC (IDF pin). The resistor R8 sets the GF threshold per the following equation:

$$I_{diff} = \frac{0.203 \times CT_1 \times (R_{CT1} + R_1 + 2\pi f_{AC} L_{CT1})}{R_8 \times (R_{CT1} + 2\pi f_{AC} L_{CT1})} \quad (\text{eq. 1})$$

CT₁ = Turns ratio of differential CT

R_{CT1} = DC winding resistance of differential CT

f_{AC} = AC mains frequency

L_{CT1} = Inductance of differential CT

The ground fault detection circuit has different levels of time delay before the SCR is enabled:

6 mA to 10 mA	≤ 125 ms
10 mA to 15 mA	≤ 95 ms
15 mA to 17.5 mA	≤ 75 ms
17.5 mA to 20 mA	≤ 60 ms
20 mA to 22.5 mA	≤ 50 ms
22.5 mA to 26.5 mA	≤ 40 ms
26.5 mA to 29 mA	≤ 35 ms
29 mA to 33 mA	≤ 25 ms
>33 mA	≤ 20 ms

If a very high GF occurs and a greater than 200 mV signal occurs across the CT for greater than 1.4 ms, the SCR will be enabled immediately.

Note that the above equation is for an ideal CT. In practice, the GF threshold can be +/-30% different and should be empirically set.

When the PTT pin is enabled for greater than 64 ms and if the GNE PIN is high (16 ms when GNE PIN is low), a ST cycle will be enabled. If the ST cycle passes, the SCR will be enabled. If the ST cycle fails, the LED will be enabled and blink. A PTT ST passing cycle will generate a POR reset.

The PTT pin has a 50 kΩ pull down resistor. This pin is a CMOS input with hysteresis. To enable the PTT function, the input voltage should go above 2.4 volts.

The MLD pin monitors the phase and zero cross for the AC supply. The MLD circuit clamps the pin voltage to gnd

and vda. When the pin is clamped at vda, the current is compared to a threshold so if the VAC voltage is below 87VRMS, the ST GF threshold will be reduced by 50%. This function provides for an AC under voltage detection which allows for the ST cycle to pass with a lower GF threshold. The AC UVD threshold can be user programmable by changing R7.

Grounded Neutral detection is accomplished by the addition of a GN coil to generate a “dormant oscillator” circuit. When a GN condition occurs, both the sense coil and GN coils are mutually coupled and the GN amplifier will oscillate. This oscillation can be observed at the CTG pin. When the oscillation at the CTG pin is above 1.95 volts for greater than 45 us, and if this condition (oscillation) lasts for longer than 64 ms, the internal NCS37014 logic will disable the GN amplifier to stop the CTG oscillation for approximately 90 ms. The amplifier will be enabled again and if the oscillation on the CTG pin returns, the GN fault will be detected and the SCR will be enabled (NCS37014MNATWG device GN fault requires the GN amplifier enabling and disability to go through two cycles). This total sequence cycle takes a maximum of 175 ms (350 ms for NCS37014MNATWG). During power up, an additional maximum of 80 ms is required. The maximum time required during power up is 350 ms. The sensitivity of the GN detection can be changed by capacitor C6 and resistor Rctg. The frequency of this CTG oscillation needs to be in the 2 kHz to 7 kHz.

The internal oscillator is trimmed to 2 MHz when the AC frequency is 60 Hz. If the AC frequency is lower, the GF trip threshold response time will be slower and the GN sensitivity will be lower.

When the IC logic enables the SCR gate driver circuit, the SCR pin will go high at approximately 26 degree phase angle (for AC Mains at 60 Hz) for the duration of the MLD half cycle and disable at the zero cross. The LED blinking logic will be enabled.

The RES pin is biased at 1.2 volts and should have an external precision 120 kΩ resistor connected to the GND pin. This resistor sets up an internal precision current source.

The TE pin is used for internal production testing only. A 50 kΩ pull down resistor is connected to this pin. This pin should be open or connected to the GND pin (preferred).

The GNE pin has an internal 50 kΩ pull up resistor connected to the internal 3.3 V supply. If this pin is pulled low, the GN function will be disabled.

Contact ON Semiconductor for self-test requirement details and noise filtering recommendations.

ORDERING INFORMATION

Device	Package	Shipping †
NCS37014MNATWG	QFN16 (Pb-Free)	3000 / Tape & Reel
NCS37014MNTWG		

†For information on tape and reel specifications, including part orientation and tape sizes, please refer to our Tape and Reel Packaging Specifications Brochure, BRD8011/D.

NOTE: NCS37014MNATWG is the improved version of NCS37014MNTWG with better frequency noise immunity.

MECHANICAL CASE OUTLINE PACKAGE DIMENSIONS

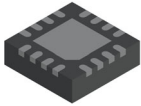

QFN16 3x3, 0.5P
CASE 485FQ
ISSUE B

DATE 12 JUL 2022

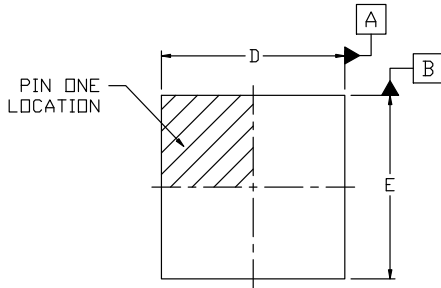

TOP VIEW

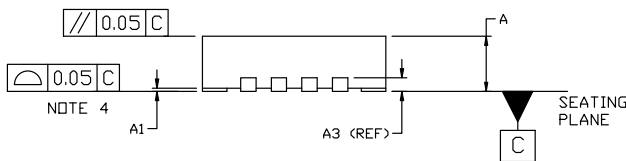

SIDE VIEW

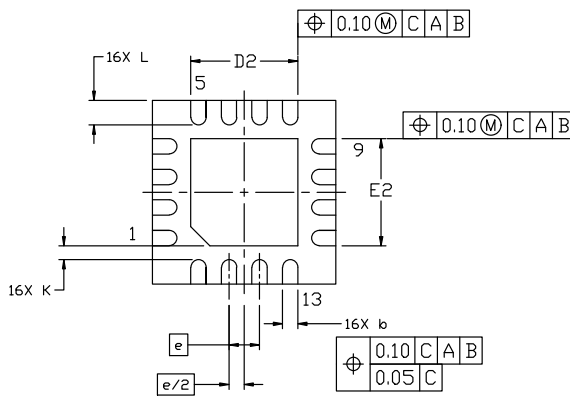

BOTTOM VIEW

NOTES:

1. DIMENSIONING AND TOLERANCING PER ASME Y14.5M, 1994.
2. CONTROLLING DIMENSION: MILLIMETERS
3. DIMENSION b APPLIES TO PLATED TERMINAL AND IS MEASURED BETWEEN 0.25 AND 0.30 MM FROM THE TERMINAL TIP.
4. COPLANARITY APPLIES TO THE EXPOSED PAD AS WELL AS THE TERMINALS.

DIM	MILLIMETERS		
	MIN.	NOM.	MAX.
A	0.80	0.90	1.00
A1	---	---	0.05
A3	0.20 REF		
b	0.18	0.24	0.30
D	2.90	3.00	3.10
D2	1.65	1.75	1.85
E	2.90	3.00	3.10
E2	1.65	1.75	1.85
e	0.50 BSC		
K	0.18 TYP		
L	0.30	0.40	0.50

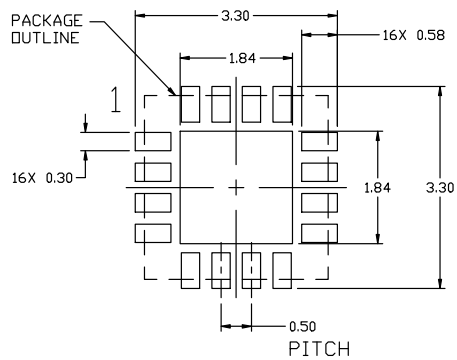

RECOMMENDED
MOUNTING FOOTPRINT*

* For additional information on our Pb-Free strategy and soldering details, please download the ON Semiconductor Soldering and Mounting Techniques Reference Manual, SOLDERRM/D.

GENERIC
MARKING DIAGRAM*

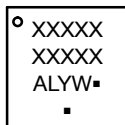

- XXXXX = Specific Device Code
- A = Assembly Location
- L = Wafer Lot
- Y = Year
- W = Work Week
- = Pb-Free Package

(Note: Microdot may be in either location)

*This information is generic. Please refer to device data sheet for actual part marking. Pb-Free indicator, "G" or microdot "▪", may or may not be present. Some products may not follow the Generic Marking.

DOCUMENT NUMBER:	98AON84763G	Electronic versions are uncontrolled except when accessed directly from the Document Repository. Printed versions are uncontrolled except when stamped "CONTROLLED COPY" in red.
DESCRIPTION:	QFN16 3x3, 0.5P	PAGE 1 OF 1

onsemi and ONSEMI are trademarks of Semiconductor Components Industries, LLC dba onsemi or its subsidiaries in the United States and/or other countries. onsemi reserves the right to make changes without further notice to any products herein. onsemi makes no warranty, representation or guarantee regarding the suitability of its products for any particular purpose, nor does onsemi assume any liability arising out of the application or use of any product or circuit, and specifically disclaims any and all liability, including without limitation special, consequential or incidental damages. onsemi does not convey any license under its patent rights nor the rights of others.

onsemi, **Onsemi**, and other names, marks, and brands are registered and/or common law trademarks of Semiconductor Components Industries, LLC dba "**onsemi**" or its affiliates and/or subsidiaries in the United States and/or other countries. **onsemi** owns the rights to a number of patents, trademarks, copyrights, trade secrets, and other intellectual property. A listing of **onsemi**'s product/patent coverage may be accessed at www.onsemi.com/site/pdf/Patent-Marking.pdf. **onsemi** reserves the right to make changes at any time to any products or information herein, without notice. The information herein is provided "as-is" and **onsemi** makes no warranty, representation or guarantee regarding the accuracy of the information, product features, availability, functionality, or suitability of its products for any particular purpose, nor does **onsemi** assume any liability arising out of the application or use of any product or circuit, and specifically disclaims any and all liability, including without limitation special, consequential or incidental damages. Buyer is responsible for its products and applications using **onsemi** products, including compliance with all laws, regulations and safety requirements or standards, regardless of any support or applications information provided by **onsemi**. "Typical" parameters which may be provided in **onsemi** data sheets and/or specifications can and do vary in different applications and actual performance may vary over time. All operating parameters, including "Typicals" must be validated for each customer application by customer's technical experts. **onsemi** does not convey any license under any of its intellectual property rights nor the rights of others. **onsemi** products are not designed, intended, or authorized for use as a critical component in life support systems or any FDA Class 3 medical devices or medical devices with a same or similar classification in a foreign jurisdiction or any devices intended for implantation in the human body. Should Buyer purchase or use **onsemi** products for any such unintended or unauthorized application, Buyer shall indemnify and hold **onsemi** and its officers, employees, subsidiaries, affiliates, and distributors harmless against all claims, costs, damages, and expenses, and reasonable attorney fees arising out of, directly or indirectly, any claim of personal injury or death associated with such unintended or unauthorized use, even if such claim alleges that **onsemi** was negligent regarding the design or manufacture of the part. **onsemi** is an Equal Opportunity/Affirmative Action Employer. This literature is subject to all applicable copyright laws and is not for resale in any manner.

PUBLICATION ORDERING INFORMATION

LITERATURE FULFILLMENT:

Email Requests to: orderlit@onsemi.com

onsemi Website: www.onsemi.com

TECHNICAL SUPPORT

North American Technical Support:

Voice Mail: 1 800-282-9855 Toll Free USA/Canada

Phone: 011 421 33 790 2910

Europe, Middle East and Africa Technical Support:

Phone: 00421 33 790 2910

For additional information, please contact your local Sales Representative