

SN54F621, SN74F621 OCTAL BUS TRANSCEIVERS WITH OPEN-COLLECTOR OUTPUTS

SDFS004B – D2932, MARCH 1987 – REVISED OCTOBER 1993

- Local Bus-Latch Capability
- Noninverting Logic
- Package Options Include Plastic Small-Outline Packages, Ceramic Chip Carriers, and Standard Plastic and Ceramic 300-mil DIPs

description

These octal bus transceivers are designed for asynchronous communication between data buses. The control function implementation allows for maximum flexibility in timing.

These devices allow data transmission from the A bus to the B bus or from the B bus to the A bus depending upon the logic levels at the output enable (OEAB and $\overline{\text{OEBA}}$) inputs.

The output-enable inputs can be used to disable the device so that the buses are effectively isolated. The dual-enable configuration gives the transceivers the capability of storing data by simultaneously enabling OEAB and $\overline{\text{OEBA}}$. Each output reinforces its input in this configuration. When both OEAB and $\overline{\text{OEBA}}$ are enabled and all other data sources to the two sets of bus lines are at high impedance, both sets of bus lines (16 in all) will remain at their last states.

The SN54F621 is characterized for operation over the full military temperature range of -55°C to 125°C . The SN74F621 is characterized for operation from 0°C to 70°C .

SN54F621 . . . J PACKAGE
SN74F621 . . . DW OR N PACKAGE
(TOP VIEW)

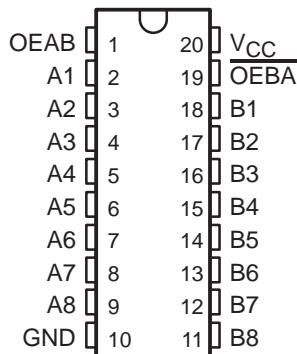

SN54F621 . . . FK PACKAGE
(TOP VIEW)

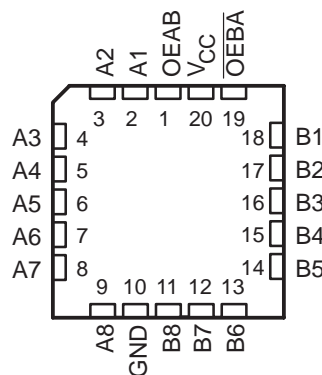

FUNCTION TABLE

INPUTS		OPERATION
$\overline{\text{OEBA}}$	OEAB	
L	L	B data to A bus
L	H	B data to A bus, A data to B bus
H	L	Isolation
H	H	A data to B bus

SN54F621, SN74F621 OCTAL BUS TRANSCEIVERS WITH OPEN-COLLECTOR OUTPUTS

SDFS004B – D2932, MARCH 1987 – REVISED OCTOBER 1993

logic symbol†

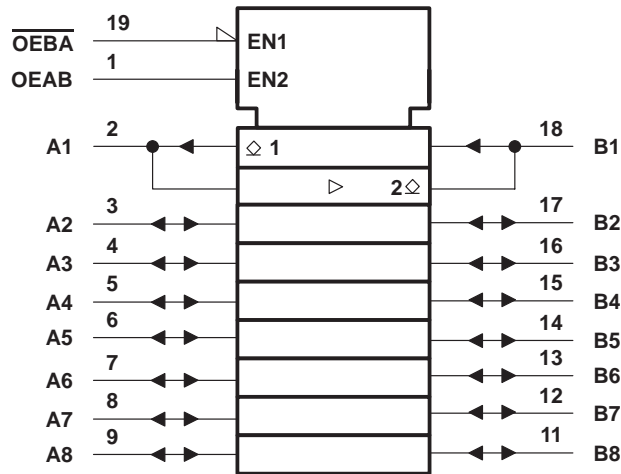

logic diagram (positive logic)

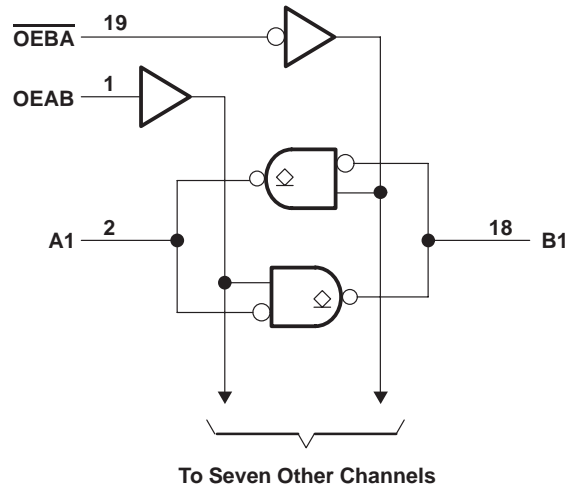

† This symbol is in accordance with ANSI/IEEE Std 91-1984 and IEC Publication 617-12.

absolute maximum ratings over operating free-air temperature range (unless otherwise noted)‡

Supply voltage range, V_{CC}	-0.5 V to 7 V
Input voltage range, V_I (excluding I/O ports) (see Note 1)	-1.2 V to 7 V
Input current range, I_{IK}	-30 mA to 5 mA
Voltage range applied to any output in the high state	-0.5 V to 5.5 V
Current into any output in the low state: SN54F621 (A1–A8)	40 mA
SN54F621 (B1–B8)	96 mA
SN74F621 (A1–A8)	48 mA
SN74F621 (B1–B8)	128 mA
Operating free-air temperature range: SN54F621	-55°C to 125°C
SN74F621	0°C to 70°C
Storage temperature range	-65°C to 150°C

‡ Stresses beyond those listed under “absolute maximum ratings” may cause permanent damage to the device. These are stress ratings only, and functional operation of the device at these or any other conditions beyond those indicated under “recommended operating conditions” is not implied. Exposure to absolute-maximum-rated conditions for extended periods may affect device reliability.

NOTE 1: The input-voltage ratings may be exceeded provided the input-current ratings are observed.

recommended operating conditions

		SN54F621			SN74F621			UNIT
		MIN	NOM	MAX	MIN	NOM	MAX	
V_{CC}	Supply voltage	4.5	5	5.5	4.5	5	5.5	V
V_{IH}	High-level input voltage	2			2			V
V_{OH}	High-level output voltage			5.5			5.5	V
V_{IL}	Low-level input voltage			0.8			0.8	V
I_{IK}	Input clamp current			-18			-18	mA
I_{OL}	Low-level output current	A1–A8		20	B1–B8		24	mA
		B1–B8		48	64			
T_A	Operating free-air temperature	-55		125	0		70	°C

electrical characteristics over recommended operating free-air temperature range (unless otherwise noted)

PARAMETER		TEST CONDITIONS		SN54F621			SN74F621			UNIT
				MIN	TYP†	MAX	MIN	TYP†	MAX	
V _{IK}		V _{CC} = 4.5 V, I _I = -18 mA		-1.2			-1.2			V
I _{OH}		V _{CC} = 4.5 V, V _{OH} = 5.5 V		250			250			μA
V _{OL}	A1–A8	V _{CC} = 4.5 V	I _{OL} = 20 mA	0.3 0.5						V
			I _{OL} = 24 mA			0.35 0.5				
	B1–B8		I _{OL} = 48 mA	0.38 0.55						
			I _{OL} = 64 mA			0.42 0.55				
I _I	A and B ports	V _{CC} = 5.5 V	V _I = 5.5 V	1		1		mA		
	OEAB or OEBA		V _I = 7 V	0.1		0.1				
I _{IH} ‡	A and B ports	V _{CC} = 5.5 V, V _I = 2.7 V		70		70		μA		
	OEAB or OEBA			20		20				
I _{IL} ‡	A and B ports	V _{CC} = 5.5 V, V _I = 0.5 V		-0.65		-0.65		mA		
	OEAB or OEBA			-0.6		-0.6				
I _{CCH}		V _{CC} = 5.5 V		105 140		105 140		mA		
I _{CCL}		V _{CC} = 5.5 V		105 140		105 140		mA		

† All typical values are at V_{CC} = 5 V, T_A = 25°C.

‡ For I/O ports, the parameters I_{IH} and I_{IL} include the off-state output current.

switching characteristics (see Note 2)

PARAMETER	FROM (INPUT)	TO (OUTPUT)	V _{CC} = 5 V, C _L = 50 pF, R _L = 500 Ω, T _A = 25°C			V _{CC} = 4.5 V to 5.5 V, C _L = 50 pF, R _L = 500 Ω, T _A = MIN to MAX§				UNIT
			'F621			SN54F621		SN74F621		
			MIN	TYP	MAX	MIN	MAX	MIN	MAX	
t _{PLH}	A	B	6	9.5	12	5.5	13	5.5	13	ns
t _{PHL}			2.5	3.8	8	2	8.5	2	8.5	
t _{PLH}	B	A	6	9	12	5.5	12.5	5.5	12.5	ns
t _{PHL}			2.5	4	7.5	2	8	2	8	
t _{PLH}	OEBA	A	6	10	13.5	5.5	14	5.5	14	ns
t _{PHL}			3.5	6.5	10.5	2.5	11	2.5	11	
t _{PLH}	OEAB	B	7	12	15	6	17	6	17	ns
t _{PHL}			3.5	6.5	9.5	3	10	3	10	

§ For conditions shown as MIN or MAX, use the appropriate value specified under recommended operating conditions.

NOTE 2: Load circuits and waveforms are shown in Section 1.

IMPORTANT NOTICE

Texas Instruments and its subsidiaries (TI) reserve the right to make changes to their products or to discontinue any product or service without notice, and advise customers to obtain the latest version of relevant information to verify, before placing orders, that information being relied on is current and complete. All products are sold subject to the terms and conditions of sale supplied at the time of order acknowledgement, including those pertaining to warranty, patent infringement, and limitation of liability.

TI warrants performance of its semiconductor products to the specifications applicable at the time of sale in accordance with TI's standard warranty. Testing and other quality control techniques are utilized to the extent TI deems necessary to support this warranty. Specific testing of all parameters of each device is not necessarily performed, except those mandated by government requirements.

CERTAIN APPLICATIONS USING SEMICONDUCTOR PRODUCTS MAY INVOLVE POTENTIAL RISKS OF DEATH, PERSONAL INJURY, OR SEVERE PROPERTY OR ENVIRONMENTAL DAMAGE ("CRITICAL APPLICATIONS"). TI SEMICONDUCTOR PRODUCTS ARE NOT DESIGNED, AUTHORIZED, OR WARRANTED TO BE SUITABLE FOR USE IN LIFE-SUPPORT DEVICES OR SYSTEMS OR OTHER CRITICAL APPLICATIONS. INCLUSION OF TI PRODUCTS IN SUCH APPLICATIONS IS UNDERSTOOD TO BE FULLY AT THE CUSTOMER'S RISK.

In order to minimize risks associated with the customer's applications, adequate design and operating safeguards must be provided by the customer to minimize inherent or procedural hazards.

TI assumes no liability for applications assistance or customer product design. TI does not warrant or represent that any license, either express or implied, is granted under any patent right, copyright, mask work right, or other intellectual property right of TI covering or relating to any combination, machine, or process in which such semiconductor products or services might be or are used. TI's publication of information regarding any third party's products or services does not constitute TI's approval, warranty or endorsement thereof.

>> [Semiconductor Home](#) > [Products](#) > [Digital Logic](#) > [Transceivers](#) > [Standard Transceivers](#) >

SN54F621, OCTAL BUS TRANSCEIVERS WITH OPEN-COLLECTOR OUTPUTS

Device Status: Active

- > [Description](#)
- > [Features](#)
- > [Datasheets](#)
- > [Pricing/Samples/Availability](#)
- > [Application Notes](#)
- > [Related Documents](#)
- > [Training](#)

Parameter Name	SN54F621
Voltage Nodes (V)	5
Vcc range (V)	4.5 to 5.5
Input Level	TTL
Output Level	TTL
No. of Outputs	8
Logic	True

Description

These octal bus transceivers are designed for asynchronous communication between data buses. The control function implementation allows for maximum flexibility in timing.

These devices allow data transmission from the A bus to the B bus or from the B bus to the A bus depending upon the logic levels at the output enable (OEAB and $\overline{\text{OEBA}}$) inputs.

The output-enable inputs can be used to disable the device so that the buses are effectively isolated. The dual-enable configuration gives the transceivers the capability of storing data by simultaneously enabling OEAB and $\overline{\text{OEBA}}$. Each output reinforces its input in this configuration. When both OEAB and $\overline{\text{OEBA}}$ are enabled and all other data sources to the two sets of bus lines are at high impedance, both sets of bus lines (16 in all) will remain at their last states.

The SN54F621 is characterized for operation over the full military temperature range of -55°C to 125°C. The SN74F621 is characterized for operation from 0°C to 70°C.

Features

- Local Bus-Latch Capability
- Noninverting Logic
- Package Options Include Plastic Small-Outline Packages, Ceramic Chip Carriers, and Standard Plastic and Ceramic 300-mil DIPs

To view the following documents, Acrobat Reader 3.x is required.

To download a document to your hard drive, right-click on the link and choose 'Save'.

Datasheets

Full datasheet in Acrobat PDF: [sdfs004b.pdf](#) (74 KB)

Full datasheet in Zipped PostScript: [sdfs004b.psz](#) (72 KB)

Pricing/Samples/Availability

<u>Orderable Device</u>	<u>Package</u>	<u>Pins</u>	<u>Temp</u>	<u>Status</u>	<u>Price/unit USD (100-999)</u>	<u>Pack Qty</u>	<u>DSCC Number</u>	<u>Availability / Samples</u>
5962-9050602SA	W	20	M	ACTIVE		1		Check stock or order
SN54F621J	J	20	M	ACTIVE	3.34	1		Check stock or order
SNJ54F621FK	FK	20	M	ACTIVE	11.52	1	5962-90506022A	Check stock or order
SNJ54F621J	J	20	M	ACTIVE	7.52	1	5962-9050602RA	Check stock or order
SNJ54F621W	J	20	M	ACTIVE		1	5962-9050602SA	Check stock or order

Application Reports

View Application Reports for [Digital Logic](#)

- [BUS-INTERFACE DEVICES WITH OUTPUT-DAMPING RESISTORS OR REDUCED-DRIVE OUTPUTS \(SCBA012A\)](#)
- [DESIGNING WITH LOGIC \(SDYA009C\)](#)
- [INPUT AND OUTPUT CHARACTERISTICS OF DIGITAL INTEGRATED CIRCUITS \(SDYA010\)](#)
- [LOGIC SOLUTIONS FOR IEEE STD 1284 \(SCEA013\)](#)
- [LVT-TO-LVTH CONVERSION \(SCEA010\)](#)

Related Documents

- [DOCUMENTATION RULES \(SAP\) AND ORDERING INFORMATION \(SZZU001B, 4 KB\)](#)
- [LOGIC SELECTION GUIDE FEBRUARY 2000 \(SDYU001M, 13837 KB\)](#)
- [MORE POWER IN LESS SPACE - TECHNICAL ARTICLE \(SCAU001A, 850 KB\)](#)

Table Data Updated on: 4/24/2000