

NCV7705(A), NCV7706

Mirror-Module Driver-IC

The NCV7705/NCV7706 is a powerful Driver-IC for automotive body control systems. The IC is designed to control several loads in the front door of a vehicle. The monolithic IC is able to control mirror functions like mirror positioning, heating and folding. In addition, NCV7706 includes the electro-chromic mirror feature. The device features four high-side outputs to drive LEDs or incandescent bulbs (up to 5/10 W). To allow maximum flexibility, all lighting outputs can be PWM controlled thru PWM inputs (external signal source) or by an internal programmable PWM generator unit. The NCV7705/NCV7706 is controlled thru a 24 bit SPI interface with in-frame response.

Features

- Operating Range from 5.5 V to 28 V
- Four High-Side and Four Low-Side Drivers Connected as Half-Bridges
 - ◆ 2x Half-bridges $I_{load} = 0.75\text{ A}$; $R_{DS(on)} = 1.6\ \Omega @ 25^\circ\text{C}$
 - ◆ 2x Half-Bridges $I_{load} = 3\text{ A}$; $R_{DS(on)} = 300\text{ m}\Omega @ 25^\circ\text{C}$
- Four High-Side Lamp Drivers
 - ◆ 2x LED; $I_{load} = 0.3\text{ A}$; $R_{DS(on)} = 1.4\ \Omega @ 25^\circ\text{C}$
 - ◆ 1x 10 W; Configurable as LED Driver; $I_{load} = 2.5\text{ A}$; $R_{DS(on)} = 300\text{ m}\Omega @ 25^\circ\text{C}$
 - ◆ 1x 5 W; Configurable as LED Driver; $I_{load} = 1.25\text{ A}$; $R_{DS(on)} = 600\text{ m}\Omega @ 25^\circ\text{C}$
- 1x High-Side Driver for Mirror Heating; $I_{load} = 6\text{ A}$; $R_{DS(on)} = 100\text{ m}\Omega @ 25^\circ\text{C}$
- Electro Chromic Mirror Control (NCV7706 Only)
 - ◆ 1x 6-Bit Selectable Output Voltage Controller
 - ◆ 1x LS for EC Control; $I_{load} = 0.75\text{ A}$; $R_{DS(on)} = 1.6\ \Omega @ 25^\circ\text{C}$
- Independent PWM Functionality for All Outputs
- Integrated Programmable PWM Generator Unit for All Lamp Driver Outputs
 - ◆ 7-bit / 10-bit Selectable Duty-cycle Setting Precision
- Programmable Soft-start Function to Drive Loads with Higher Inrush Currents as Current Limitation Value
- Multiplex Current Sense Analog Output for Advanced Load Monitoring
- Very Low Current Consumption in Standby Mode
- Charge Pump Output to Control an External Reverse Polarity Protection MOSFET
- 24-Bit SPI Interface for Output Control and Diagnostic
- Protection Against Short-circuit, Overvoltage and Over-temperature
- Downwards Pin-to-Pin and SPI Registers Compatible with NCV7707
- AEC-Q100 Qualified and PPAP Compliant



ON Semiconductor®

www.onsemi.com

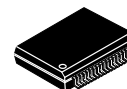

SSOP36 EP
DQ SUFFIX
CASE 940AB

MARKING DIAGRAM

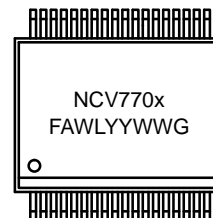

NCV770x = Specific Device Code
(x = 5, 5A or 6)

F = Fab Location (NCV7705A only)
A = Assembly Location
WL = Wafer Lot
YY = Year
WW = Work Week
G = Pb-Free Package

ORDERING INFORMATION

Device	Package	Shipping†
NCV7705DQR2G	SSOP36-EP GREEN (Pb-Free)	1500 / Tape & Reel
NCV7705DQAR2G		
NCV7706DQR2G*		

†For information on tape and reel specifications, including part orientation and tape sizes, please refer to our Tape and Reel Packaging Specification Brochure, BRD8011/D.

* Contact local sales office for availability

- SSOP36-EP Power Package
- This is a Pb-Free Device

Typical Applications

- De-centralized Door Electronic Systems
- Body Control Units (BCUs)

NCV7705(A), NCV7706

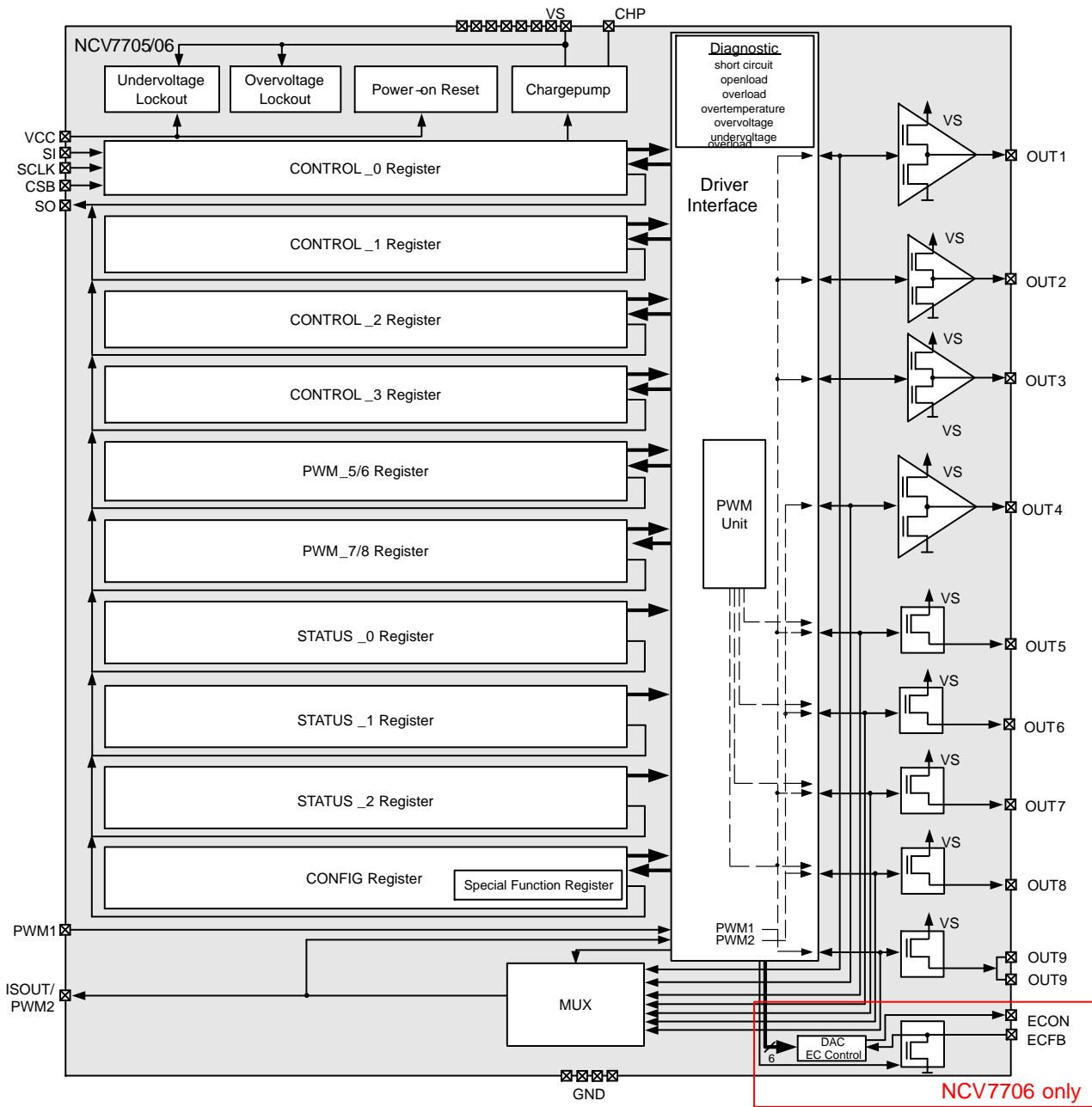

Figure 1. Block Diagram

NCV7705(A), NCV7706

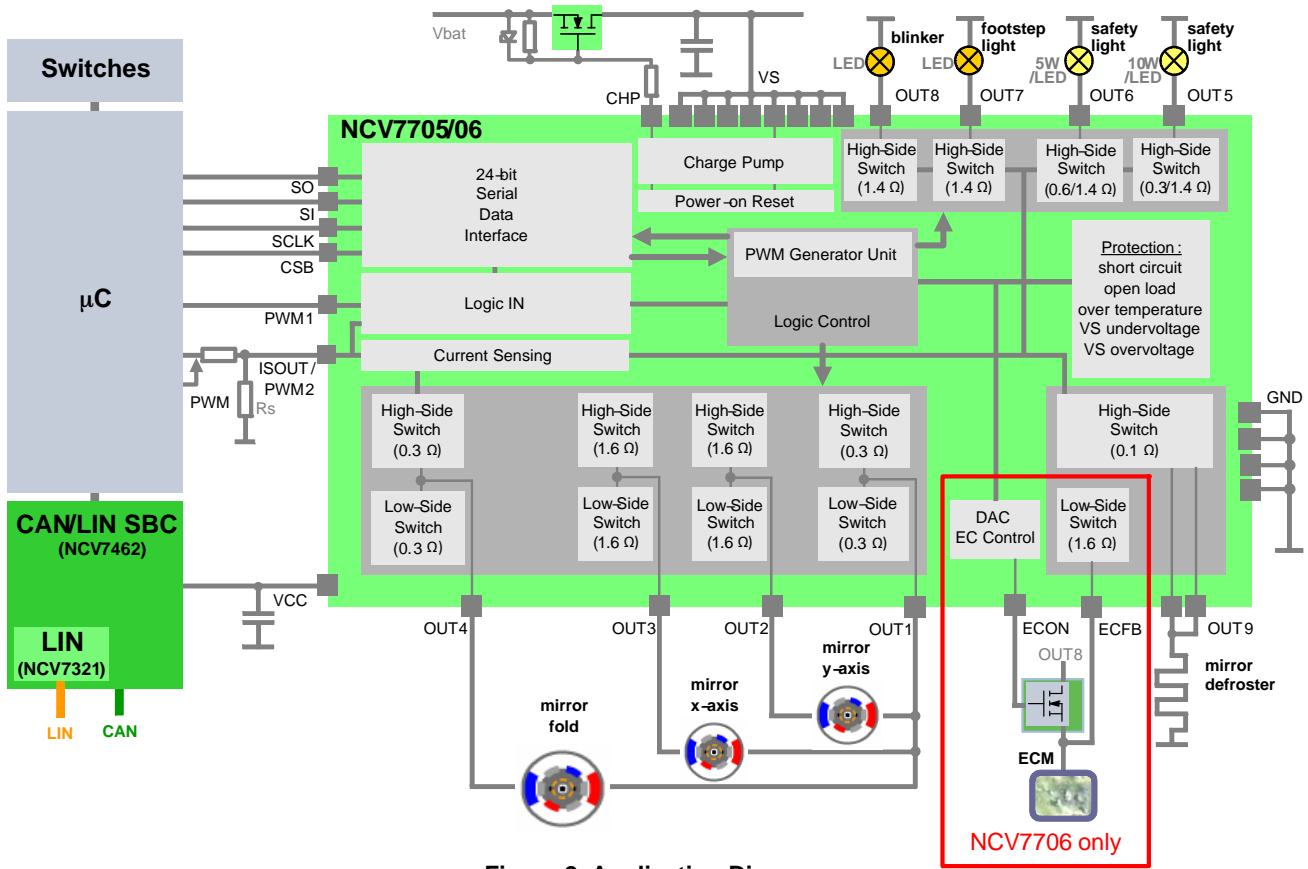

Figure 2. Application Diagram

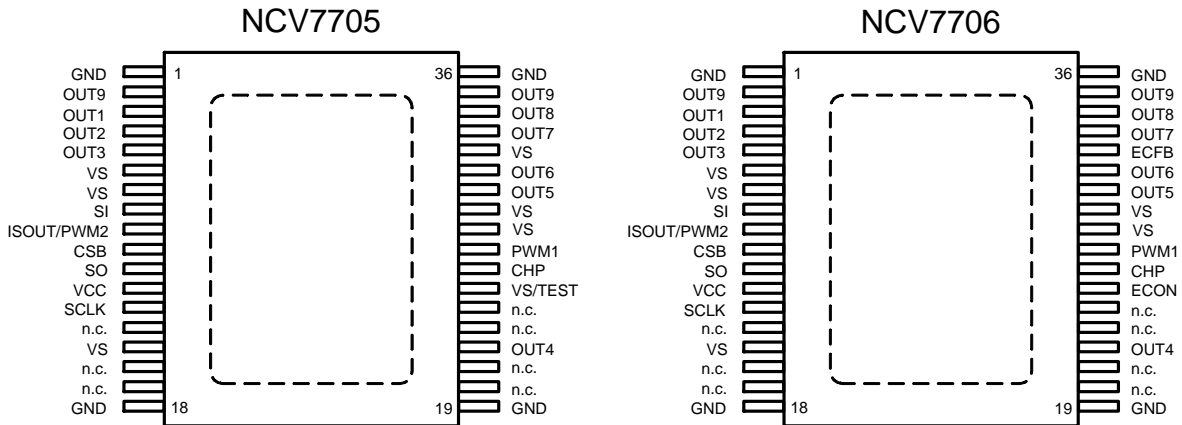

Figure 3. Pin Connections (Top View)

NCV7705(A), NCV7706

PIN FUNCTION DESCRIPTION

Pin No.	Pin Name	Pin Type	Description
1	GND	Ground	Ground Supply (all GND pins have to be connected externally)
2	OUT9	HS driver Output	Heater Output (has to be connected externally to pin 35)
3	OUT1	Half bridge driver Output	Mirror common Output
4	OUT2	Half bridge driver Output	Mirror x/y control Output
5	OUT3	Half bridge driver Output	Mirror x/y control Output
6	VS	Supply	Battery Supply Input (all VS pins have to be connected externally)
7	VS	Supply	Battery Supply Input (all VS pins have to be connected externally)
8	SI	Digital Input	SPI interface Serial Data Input
9	ISOUT/PWM2	Digital Input / Analog Output	PWM control Input / Current Sense Output. This pin is a bidirectional pin. Depending on the selected multiplexer bits, an image of the instant current of the corresponding HS stage can be read out. This pin can also be used as PWM control input pin for OUT6 and OUT8.
10	CSB	Digital Input	SPI interface Chip Select
11	SO	Digital Output	SPI interface Serial Data Output
12	VCC	Supply	Logic Supply Input
13	SCLK	Digital Input	SPI interface Shift Clock
14	n.c.		Not connected
15	VS	Supply	Battery Supply Input (all VS pins have to be connected externally)
16	n.c.		Not connected
17	n.c.		Not connected
18	GND	Ground	Ground Supply (all GND pins have to be connected externally)
19	GND	Ground	Ground Supply (all GND pins have to be connected externally)
20	n.c.		Not connected
21	n.c.		Not connected
22	OUT4	Half bridge driver Output	Mirror Fold Output
23	n.c.		Not connected
24	n.c.		Not connected
25	VS/TEST (NCV7705 only)	Supply	Test Input, has to be connected to VS in application
	ECON (NCV7706 only)	ECM driver Output	Electrochromic mirror control DAC output. If the Electrochrome feature is selected, this output controls an external Mosfet, otherwise it remains in high-impedance state. If the electrochrome feature is not used in the application and not selected via SPI the pin can be connected to VS.
26	CHP	Analog Output	Reverse Polarity FET Control Output
27	PWM1	Digital Input	PWM control Input for OUT1–4, OUT5/7, OUT9
28	VS	Supply	Battery Supply Input (all VS pins have to be connected externally)
29	VS	Supply	Battery Supply Input (all VS pins have to be connected externally)
30	OUT5	HS driver Output	LED / Bulb Output
31	OUT6	HS driver Output	LED / Bulb Output
32	VS (NCV7705 only)	Supply	Connect to VS pins externally (no power connection)
	ECFB (NCV7706 only)	ECM Input / Output	Electrochromic Mirror Feedback Input, Fast discharge transistor Output
33	OUT7	HS driver Output	LED Output
34	OUT8	HS driver Output	LED Output
35	OUT9	HS driver Output	Heater Output (has to be connected externally to pin 2)
36	GND	Ground	Ground Supply (all GND pins have to be connected externally)
	Heat slug	Ground	Substrate; Heat slug has to be connected to all GND pins

NCV7705(A), NCV7706

ABSOLUTE MAXIMUM RATINGS

Symbol	Rating	Min	Max	Unit
Vs	Power supply voltage – Continuous supply voltage – Transient supply voltage (t < 500 ms, "clamped load dump")	-0.3 -0.3	28 40	V
V _{CC}	Logic supply	-0.3	5.5	V
Vdig	DC voltage at all logic pins (SO, SI, SCLK, CSB, PWM1)	-0.3	V _{CC} + 0.3	V
Visout/pwm2	Current monitor output / PWM2 logic input	-0.3	V _{CC} + 0.3	V
Vchp	Charge pump output (the most stringent value is applied)	-25 Vs - 25	40 Vs + 15	V
Voutx, Vecon, Vecfb	Static output voltage (OUT1-9, ECON, ECFB)	-0.3	Vs + 0.3	V
Iout1/4	OUT1/4 Output current – T _J > 25°C – T _J < 25°C	-5 -5.5	5 5.5	A
Iout2/3	OUT2/3 Output current – T _J > 25°C – T _J < 25°C	-1.25 -1.35	1.35 1.35	A
Iout5	OUT5 Output current – DC – Transient	-5	5	A
Iout6	OUT6 Output current – DC – Transient	-2.5	2.5	A
Iout7/8	OUT7/8 Output current – DC – Transient	-1.25	1.25	A
Iout9	OUT9 Output current – DC – Transient	-10	10	A
Iout_ecfb (NCV7706 only)	ECFB Output current		1.25	A
ESD_HBM	ESD Voltage, Human Body Model (HBM); (100 pF, 1500 Ω) (Note 1) – All pins – Output pins OUT1-4 and ECFB to GND (all unzapped pins grounded)	-2 -4	2 4	kV
ESD_CDM	ESD according to CDM (Charge Device Model) (Note 1) – All pins – Corner pins	-500 -750	500 750	V
T _J	Operating junction temperature range	-40	150	°C
Tstg	Storage temperature range	-55	150	°C
MSL	Moisture sensitivity level (Note 2)	MSL3		

Stresses exceeding those listed in the Maximum Ratings table may damage the device. If any of these limits are exceeded, device functionality should not be assumed, damage may occur and reliability may be affected.

1. This device series incorporates ESD protection and is tested by the following methods:

ESD Human Body Model tested per AEC-Q100-002 (EIA/JESD22-A114)

ESD Charge Device Model tested per EIA/JES D22/C101, Field Induced Charge Model

2. For soldering information, please refer to our Soldering and Mounting Techniques Reference Manual, SOLDERRM/D

THERMAL CHARACTERISTICS

Symbol	Rating	Value	Unit
R _{θJA}	Thermal Characteristics, SSOP36-EP, 1-layer PCB Thermal Resistance, Junction-to-Air (Note 3)	49.4	°C/W
R _{θJA}	Thermal Characteristics, SSOP36-EP, 4-layer PCB Thermal Resistance, Junction-to-Air (Note 4)	24	°C/W

3. Values based on PCB of 76.2 x 114.3 mm, 72 μm copper thickness, 20% copper area coverage and FR4 PCB substrate.

4. Values based on PCB of 76.2 x 114.3 mm, 72 / 36 μm copper thickness (signal layers / internal planes), 20 / 90% copper area coverage (signal layers / internal planes) and FR4 PCB substrate.

NCV7705(A), NCV7706

ELECTRICAL CHARACTERISTICS

4.5 V < V_{CC} < 5.25 V, 8 V < V_s < 18 V, -40°C < T_J < 150°C; unless otherwise noted.

Symbol	Parameter	Test Conditions	Min	Typ	Max	Unit
--------	-----------	-----------------	-----	-----	-----	------

SUPPLY

V _s	Supply voltage	Functional (see V _{UV_Vs} / V _{OV_Vs}) Parameter specification	5.5 8		28 18	V
I _{s(standby)}	Supply Current (V _S), Standby mode	Standby mode, V _S = 16 V, 0 V ≤ V _{CC} ≤ 5.25 V, CSB = V _{CC} , OUTx/ECx = floating, SI = SCLK = 0 V, T _J < 85°C (T _J = 150°C)		3.5 (9)	12 (25)	μA
I _{s(active)}	Supply current (V _S), Active mode	Active mode, V _S = 16 V, OUTx/ECx = floating		8	20	mA
I _{CC(standby)}	Supply Current (V _{CC}), Standby mode	Standby mode, V _{CC} = 5.25 V, SI = SCLK = 0 V, T _J < 85°C (T _J = 150°C)		4.5 (15)	6 (50)	μA
I _{CC(active)}	Supply current (V _{CC}), Active mode	Active mode, V _S = 16 V, OUTx/ECx = floating		6.5	8	mA
I _(standby)	Total Standby mode supply current (I _s + I _{CC})	Standby mode, V _S = 16 V, T _J < 85°C, CSB = V _{CC} , OUTx/ECx = floating		8	18	μA

OVERVOLTAGE AND UNDERVOLTAGE DETECTION

V _{uv_vs(on)}	V _S Undervoltage detection	V _S increasing	5.6		6.2	V
V _{uv_vs(off)}		V _S decreasing	5.2		5.8	V
V _{uv_vs(hys)}	V _S Undervoltage hysteresis	V _{uv_vs(on)} – V _{uv_vs(off)}		0.65		V
V _{ov_vs(off)}	V _S Overvoltage detection	V _S increasing	20		24.5	V
V _{ov_vs(on)}		V _S decreasing	19		23.5	V
V _{ov_vs(hys)}	V _S Overvoltage hysteresis	V _{ov_vs(off)} – V _{ov_vs(on)}		2		V
V _{uv_vcc(off)}	V _{CC} Undervoltage detection	V _{CC} increasing			2.9	V
V _{uv_vcc(on)}		V _{CC} decreasing	2			V
V _{uv_vcc(hys)}	V _{CC} Undervoltage hysteresis	V _{uv_VCC(off)} – V _{uv_VCC(on)}		0.11		V
td_uv	V _S Undervoltage filter time	Time to set the power supply fail bit UOV_OC in the Global Status Byte	6		13	μs
td_ov	V _S Overvoltage filter time	Time to set the power supply fail bit UOV_OC in the Global Status Byte	50		100	μs

CHARGE PUMP OUTPUT CHP

V _{chp8}	Chargepump Output Voltage	V _s = 8 V, I _{chp} = -60 μA	V _s + 6	V _s + 9.5	V _s + 13	V
V _{chp10}	Chargepump Output Voltage	V _s = 10 V, I _{chp} = -80 μA	V _s + 8	V _s + 11	V _s + 13	V
V _{chp12}	Chargepump Output Voltage	V _s > 12 V, I _{chp} = -100 μA	V _s + 9.5	V _s + 11	V _s + 13	V
I _{chp}	Chargepump Output current	V _S = 13.5 V, V _{chp} = V _s + 10 V	-750		-95	μA

NCV7705(A), NCV7706

ELECTRICAL CHARACTERISTICS (continued)

4.5 V < V_{CC} < 5.25 V, 8 V < V_s < 18 V, -40°C < T_J < 150°C; unless otherwise noted.

Symbol	Parameter	Test Conditions	Min	Typ	Max	Unit
MIRROR COMMON OUTPUT (X/Y, FOLD) OUT1, OUT4						
Ron_out1,4	On-resistance HS or LS	T _J = 25°C, I _{out1,4} = ±1.5 A		0.3		Ω
		T _J = 125°C, I _{out1,4} = ±1.5 A			0.6	
Ioc1,4_hs	Overcurrent threshold HS	T _J < 25°C T _J ≥ 25°C	-5.5 -5		-3	A
Ioc1,4_ls	Overcurrent threshold LS	T _J < 25°C T _J ≥ 25°C	3		5.5 5	A
Vlim1,4	V _{ds} voltage limitation HS or LS		2		3	V
Iuld1,4_hs	Underload detection threshold HS		-80		-5	mA
Iuld1,4_ls	Underload detection threshold LS		5		80	mA
td_HS1,4(on)	Output delay time, HS Driver on	Time from CSB going high to V(OUT1,4) = 0.1·V _s / 0.9·V _s (on/off)		2.5	12	μs
td_HS1,4(off)	Output delay time, HS Driver off			3	12	μs
td_LS1,4(on)	Output delay time, LS Driver on	Time from CSB going low to V(OUT1,4) = 0.9·V _s / 0.1·V _s (on/off)		1	12	μs
td_LS1,4(off)	Output delay time, LS Driver off			1.5	12	μs
tdLH1,4	Cross conduction protection time, low-to-high transition including LS slew-rate			0.5	22	μs
tdHL1,4	Cross conduction protection time, high-to-low transition including HS slew-rate			5.5	22	μs
Ileak_act_hs1,4	Output HS leakage current, Active mode	V(OUT1,4) = 0 V	-40	-16		μA
Ileak_act_ls1,4	Output pull-down current, Active mode	V(OUT1,4) = V _s		105	185	μA
Ileak_stdbys1,4	Output HS leakage current, Standby mode	V(OUT1,4) = 0 V	-5			μA
Ileak_stdbys_ls1,4	Output pull-down current, Standby mode	V(OUT1,4) = V _s , T _J ≥ 25°C V(OUT1,4) = V _s , T _J < 25°C		80	120 175	μA
td_uld1,4	Underload blanking delay		430		610	μs
tdb_old1,4	Overload shutdown blanking delay	Timer started after output activation	16		25	μs
td_old1,4	Overload shutdown filter time	Timer started after blanking delay elapsed	5		25	μs
frec1,4L	Recovery frequency, slow recovery mode	CONTROL_3.OCRf = 0	1		4	kHz
frec1,4H	Recovery frequency, fast recovery mode	CONTROL_3.OCRf = 1	2		6	kHz
dVout1,4	Slew rate of HS driver	V _s = 13.5 V, R _{load} = 16 Ω to GND	1.3	2.3	3.3	V/μs

NCV7705(A), NCV7706

ELECTRICAL CHARACTERISTICS (continued)

4.5 V < V_{CC} < 5.25 V, 8 V < V_s < 18 V, -40°C < T_J < 150°C; unless otherwise noted.

Symbol	Parameter	Test Conditions	Min	Typ	Max	Unit
MIRROR X/Y POSITIONING OUTPUTS OUT2, OUT3						
Ron_out2,3	On-resistance HS or LS	T _J = 25°C, I _{out2,3} = ±0.5 A		1.6		Ω
		T _J = 125°C, I _{out2,3} = ±0.5 A			3	Ω
Ioc2,3_hs	Overcurrent threshold HS	T _J < 25°C T _J ≥ 25°C	-1.35 -1.25		-0.75	A
Ioc2,3_ls	Overcurrent threshold LS	T _J < 25°C T _J ≥ 25°C	0.75		1.35 1.25	A
Vlim2,3	V _{ds} voltage limitation HS or LS		2		3	V
Iuld2,3_hs	Underload detection threshold HS		-32	-20	-10	mA
Iuld2,3_ls	Underload detection threshold LS		10	20	32	mA
td_HS2,3(on)	Output delay time, HS Driver on	Time from CSB going high to V(OUT2,3) = 0.1·V _s / 0.9·V _s (on/off)		2.5	6	μs
td_HS2,3(off)	Output delay time, HS Driver off			3	6	μs
td_LS2,3(on)	Output delay time, LS Driver on	Time from CSB going low to V(OUT2,3) = 0.9·V _s / 0.1·V _s (on/off)		1	6	μs
td_LS2,3(off)	Output delay time, LS Driver off			1	6	μs
tdLH2,3	Cross conduction protection time, low-to-high transition including LS slew-rate			0.5	22	μs
tdHL2,3	Cross conduction protection time, high-to-low transition including HS slew-rate			5.5	22	μs
Ileak_act_hs2,3	Output HS leakage current, Active mode	V(OUT2,3) = 0 V	-40	-16		μA
Ileak_act_ls2,3	Output pull-down current, Active mode	V(OUT2,3) = V _s		105	185	μA
Ileak_stdbys_hs2,3	Output HS leakage current, Standby mode	V(OUT2,3) = 0 V	-5			μA
Ileak_stdbys_ls2,3	Output pull-down current, Standby mode	V(OUT2,3) = V _s , T _J ≥ 25°C V(OUT2,3) = V _s , T _J < 25°C		80	120 175	μA μA
td_uld2,3	Underload blanking delay		430		610	μs
tdb_ol2,3	Overload shutdown blanking delay	Timer started after output activation	16		25	μs
td_ol2,3	Overload shutdown filter time	Timer started after blanking delay elapsed	16		50	μs
frec2,3L	Recovery frequency, slow recovery mode	CONTROL_3.OCRf = 0	1		4	kHz
frec2,3H	Recovery frequency, fast recovery mode	CONTROL_3.OCRf = 1	2		6	kHz
dVout2,3	Slew rate of HS driver	V _s = 13.5 V, R _{load} = 64 Ω to GND	1.3	2.3	3.3	V/μs

NCV7705(A), NCV7706

ELECTRICAL CHARACTERISTICS (continued)

4.5 V < V_{CC} < 5.25 V, 8 V < V_s < 18 V, -40°C < T_J < 150°C; unless otherwise noted.

Symbol	Parameter	Test Conditions	Min	Typ	Max	Unit
BULB / LED DRIVER OUTPUT OUT5						
Ron_out5_ICB	On-resistance to supply, HS switch, Bulb mode	T _J = 25°C, I _{out5} = -1 A		0.3		Ω
		T _J = 125°C, I _{out5} = -1 A			0.6	
Ron_out5_LED	On-resistance to supply, HS switch, LED mode	T _J = 25°C, I _{out5} = -0.2 A		1.4		Ω
		T _J = 125°C, I _{out5} = -0.2 A			3	
Ilim5_ICB	Output current limitation to GND, Bulb mode	T _J < 25°C T _J ≥ 25°C	-3.9 -3.7		-2.5	A
Ilim5_LED	Overcurrent threshold, LED mode		-1.1		-0.5	A
Iuld5_ICB	Underload detection threshold, Bulb mode		-65		-5	mA
Iuld5_LED	Underload detection threshold, LED mode		-15		-5	mA
td_OUT5_ICB(on)	Output delay time, Driver on, Bulb mode	Time from CSB going high to V(OUT5) = 0.1·Vs / 0.9·Vs (on/off); Rload = 16 Ω		15	48	μs
td_OUT5_ICB(off)	Output delay time, Driver off, Bulb mode			21	48	
td_OUT5_LED(on)	Output delay time, Driver on, LED mode	Time from CSB going high to V(OUT5) = 0.1·Vs / 0.9·Vs (on/off); Rload = 64 Ω		15	48	μs
td_OUT5_LED(off)	Output delay time, Driver off, LED mode			21	48	
Ileak_act5	Output leakage current, Active mode	V(OUT5) = 0 V	-15			μA
Ileak_stdb5	Output leakage current, Standby mode	V(OUT5) = 0 V	-5			μA
Ileak_out_vs5	Output leakage current	V(OUT5) = VS			1	mA
td_uld5_ICB	Underload blanking delay Bulb mode		1350		1910	μs
td_uld5_LED	Underload blanking delay LED mode		430		610	μs
tdb_old_ICB5	Overload shutdown blanking delay, Bulb mode	Timer started after output activation	200		290	μs
td_old_ICB5	Overload shutdown filter time, Bulb mode	Timer started after blanking delay elapsed	100		160	μs
tdb_old_LED5	Overload shutdown blanking delay, LED mode	Timer started after output activation	200		290	μs
td_old_LED5	Overload shutdown filter time, LED mode	Timer started after blanking delay elapsed	50		100	μs
frec5L	Recovery frequency, slow recovery mode recovery	CONTROL_3.OCRf = 0	1		2.1	kHz
frec5H	Recovery frequency, fast recovery mode (LED mode only)	CONTROL_3.OCRf = 1	2		6	kHz
dVout5_ICB	Slew rate, Bulb mode	Vs = 13.5 V, Rload = 16 Ω		0.22		V/μs
dVout5_LED	Slew rate, LED mode	Vs = 13.5 V, Rload = 64 Ω		0.22		V/μs
dVout5_ocr	Slew rate in overcurrent recovery mode	Vs = 13.5 V, Rload = 16 Ω	1	2	3	V/μs

NCV7705(A), NCV7706

ELECTRICAL CHARACTERISTICS (continued)

4.5 V < V_{CC} < 5.25 V, 8 V < V_s < 18 V, -40°C < T_J < 150°C; unless otherwise noted.

Symbol	Parameter	Test Conditions	Min	Typ	Max	Unit
BULB / LED DRIVER OUTPUT OUT6						
Ron_out6_ICB	On-resistance to supply, HS switch, Bulb mode	T _J = 25°C, I _{out6} = -0.5 A		0.6		Ω
		T _J = 125°C, I _{out6} = -0.5 A			1.2	
Ron_out6_LED	On-resistance to supply, HS switch, LED mode	T _J = 25°C, I _{out6} = -0.2 A		1.4		Ω
		T _J = 125°C, I _{out6} = -0.2 A			3	
Ilim6_ICB	Output current limitation to GND, Bulb mode	T _J < 25°C T _J ≥ 25°C	-1.95 -1.85		-1.25	A
Ilim6_LED	Overcurrent threshold, LED mode		-1.1		-0.5	A
Iuld6_ICB	Underload detection threshold, Bulb mode		-30		-2.5	mA
Iuld6_LED	Underload detection threshold, LED mode		-15		-5	mA
td_OUT6_ICB(on)	Output delay time, Driver on, Bulb mode	Time from CSB going high to V(OUT6) = 0.1·Vs / 0.9·Vs (on/off); Rload = 16 Ω		15	48	μs
td_OUT6_ICB(off)	Output delay time, Driver off, Bulb mode			21	48	
td_OUT6_LED(on)	Output delay time, Driver on, LED mode	Time from CSB going high to V(OUT6) = 0.1·Vs / 0.9·Vs (on/off); Rload = 64 Ω		15	48	μs
td_OUT6_LED(off)	Output delay time, Driver off, LED mode			21	48	
Ileak_act6	Output leakage current, Active mode	V(OUT6) = 0 V	-15			μA
Ileak_stdy6	Output leakage current, Standby mode	V(OUT6) = 0 V	-5			μA
Ileak_out_vs6	Output leakage current	V(OUT6) = VS			1	mA
td_uld6_ICB	Underload blanking delay Bulb mode		1350		1910	μs
td_uld6_LED	Underload blanking delay LED mode		430		610	μs
tdb_old_ICB6	Overload shutdown blanking delay, Bulb mode	Timer started after output activation	200		290	μs
td_old_ICB6	Overload shutdown filter time, Bulb mode	Timer started after blanking delay elapsed	100		160	μs
tdb_old_LED6	Overload shutdown blanking delay, LED mode	Timer started after output activation	200		290	μs
td_old_LED6	Overload shutdown filter time, LED mode	Timer started after blanking delay elapsed	50		100	μs
frec6L	Recovery frequency, slow recovery mode recovery	CONTROL_3.OCRf = 0	1		2.1	kHz
frec6H	Recovery frequency, fast recovery mode (LED mode only)	CONTROL_3.OCRf = 1	2		6	kHz
dVout6_ICB	Slew rate, Bulb mode	Vs = 13.5 V, Rload = 16 Ω		0.22		V/μs
dVout6_LED	Slew rate, LED mode	Vs = 13.5 V, Rload = 64 Ω		0.22		V/μs
dVout6_ocr	Slew rate in overcurrent recovery mode	Vs = 13.5 V, Rload = 16 Ω	1	2	3	V/μs

NCV7705(A), NCV7706

ELECTRICAL CHARACTERISTICS (continued)

4.5 V < V_{CC} < 5.25 V, 8 V < V_s < 18 V, -40°C < T_J < 150°C; unless otherwise noted.

Symbol	Parameter	Test Conditions	Min	Typ	Max	Unit
--------	-----------	-----------------	-----	-----	-----	------

LED DRIVER OUTPUTS OUT7, OUT8

Ron_out7,8	On-resistance to supply, HS switch	T _J = 25°C, I _{out7,8} = -0.2 A		1.4		Ω
		T _J = 125°C, I _{out7,8} = -0.2 A			3	Ω
Ioc7,8	Overcurrent threshold		-0.6		-0.3	A
Iuld7,8	Underload detection threshold		-18		-4	mA
td_OUT7,8(on)	Output delay time, Driver on	Time from CSB going high to V(OUT7,8) = 0.1·V _s / 0.9·V _s (on/off)			48	μs
td_OUT7,8(off)	Output delay time, Driver off				48	
Ileak_act7,8	Output leakage current, Active mode	V(OUT7,8) = 0 V	-10	18		μA
Ileak_stdby7,8	Output leakage current, Standby mode	V(OUT7,8) = 0 V	-5	23		μA
Ileak_out_vs7,8	Output leakage current	V(OUT7,8) = V _S			1	mA
td_uld7,8	Underload blanking delay		430		610	μs
tdb_old_OUT7,8	Overload shutdown blanking delay	Timer started after output activation	200		290	μs
td_old_OUT7,8	Overload shutdown filter time	Timer started after blanking delay elapsed	16		50	μs
frec7,8L	Recovery frequency, slow recovery mode	CONTROL_3.OCRf = 0	1		4	kHz
frec7,8H	Recovery frequency, fast recovery mode	CONTROL_3.OCRf = 1	2		6	kHz
dVout7,8	Slew rate	V _s = 13.5 V, R _{load} = 64 Ω		0.2		V/μs

HEATER OUTPUT OUT9

Ron_out9	On-resistance to supply, HS switch	T _J = 25°C, I _{out9} = -3 A		0.1		Ω
		T _J = 125°C, I _{out9} = -3 A			0.2	Ω
Ioc9	Overcurrent threshold		-10		-6	A
Iuld9	Underload detection threshold		-300		-30	mA
td_OUT9(on)	Output delay time, Driver on	Time from CSB going high to V(OUT9) = 0.1·V _s / 0.9·V _s (on/off); R _{load} = 64 Ω		3	12	μs
td_OUT9(off)	Output delay time, Driver off			3	12	
Ileak_act9	Output leakage current, Active mode	V(OUT9) = 0 V	-10			μA
Ileak_stdby9	Output leakage current, Standby mode	V(OUT9) = 0 V	-5			μA
Ileak_out9_vs	Output leakage current	V(OUT9) = V _S			1	mA
td_uld9	Underload blanking delay		430		610	μs
tdb_old_OUT9	Overload shutdown blanking delay	Timer started after output activation	30		48	μs
td_old_OUT9	Overload shutdown blanking delay	Timer started after blanking delay elapsed	16		25	μs
frec9L	Recovery frequency, slow recovery mode	CONTROL_3.OCRf = 0	1		4	kHz
frec9H	Recovery frequency, fast recovery mode	CONTROL_3.OCRf = 1	2		6	kHz
dVout9	Slew rate	V _s = 13.5 V, R _{load} = 4 Ω	1.3	2.3	3.3	V/μs

NCV7705(A), NCV7706

ELECTRICAL CHARACTERISTICS (continued)

4.5 V < V_{CC} < 5.25 V, 8 V < V_s < 18 V, -40°C < T_J < 150°C; unless otherwise noted.

Symbol	Parameter	Test Conditions	Min	Typ	Max	Unit
ELECTROCHROMIC MIRROR CONTROL (ECFB, ECON) (NCV7706 ONLY)						
Ron_ecfb	On-resistance to GND, LS switch	T _J = 25°C, I _{ecfb} = 0.5 A		1.6		Ω
		T _J = 125°C, I _{ecfb} = 0.5 A			3	Ω
Ilim_ecfb_src	Output current limitation to GND	V _s = 13.5 V, V _{CC} = 5 V	0.75		1.25	A
Vlim_ecfb	V _{ds} voltage limitation	Output enabled	2		3	V
Iuld_ecfb	Underload detection threshold	V _s = 13.5 V, V _{CC} = 5 V	10	20	35	mA
td_ecfb(on)	Output delay time, LS Driver on	V _s = 13.5 V, V _{CC} = 5 V, R _{load} = 64 Ω, V(ECFB) = 0.9·V _S / 0.1·V _S (on / off)		1	12	μs
td_ecfb(off)	Output delay time, LS Driver off			2	12	
Ileak_ecfb_stdby	Output leakage current, LS off	V _{ecfb} = V _s , Standby mode	-15		15	μA
Ileak_ecfb_act		V _{ecfb} = V _s , Active mode	-10		10	μA
td_uld_ecfb	Underload blanking delay		430		610	μs
tdb_old_ecfb	Overload shutdown blanking delay	Timer started after output activation	30		48	μs
td_old_ecfb	Overload shutdown filter time	Timer started after blanking delay elapsed	16		50	μs
dVecfb/dt(on/off)	Slew rate of ECFB, LS switch	V _s = 13.5 V, V _{CC} = 5 V, R _{load} = 64 Ω		5		V/μs
Vctrl_max	Maximum EC control voltage	CONTROL_2.FSR = 1	1.4		1.6	V
		CONTROL_2.FSR = 0	1.12		1.28	V
DNL	Differential non linearity	1 LSB = 23.8 mV	-1		1	LSB
dV_ecfb	Voltage deviation between target and ECFB	dV _{ecfb} = V _{target} - V _{ecfb} , I _{econ} < 1 μA gain offset	-5% -1 LSB		+5% +1 LSB	mV
dV_ecfb_lo	Difference voltage between target and ECFB sets flag if V _{ecfb} is below target	dV _{ecfb} = V _{target} - V _{ecfb} , Toggle bit STATUS_2.ECLO = 1		120		mV
dV_ecfb_hi	Difference voltage between target and ECFB sets flag if V _{ecfb} is above target	dV _{ecfb} = V _{target} - V _{ecfb} , Toggle bit STATUS_2.ECHI = 1		-120		mV
Vecon_min_hi	ECON output voltage range	I _{econ} = -10 μA	4.5		5.5	V
Vecon_max_lo		I _{econ} = 10 μA	0		0.7	
Iecon	ECON output current capability	V _{target} > V _{ecfb} + 500 mV, V _{ecfb} = 3.5 V	-100		-10	μA
		V _{target} < V _{ecfb} - 500 mV, V _{econ} = 0.5 V, V _{target} = 1 LSB, V _{ecfb} = 0.5 V	10		100	μA
Recon_pd	Pull-down resistance at ECON in fast discharge mode	V _{econ} = 0.7 V, CONTROL_1.ECEN = 1, CONTROL_1.LSECFB = 1, CONTROL_1.DAC[5:0] = 0			5	kΩ
Iq_econ	ECON quiescent current	V _{econ} = V _s , CONTROL_1.ECEN = 0			1	μA
t_disc	Auto-discharge pulse width	Config.LSPWM=1	230	300	360	ms
t_rec	Auto-discharge blanking time	Config.LSPWM=1	2.25	3	3.75	ms
Vthdisc_abs	PWM discharge threshold level V(ECON) (Note 5)	Config.LSPWM=1	350	400	450	mV
Vthdisc_diff	PWM discharge threshold level V(ECON) - V(ECFB) (Note 5)	Config.LSPWM=1	-50	0	50	mV

5. If V(ECON) < Vthdisc_abs or V(ECON)-V(ECFB) < Vthdisc_diff then ECON_LOW =1; see description in paragraph Controller for Electro-chromic Glass

NCV7705(A), NCV7706

ELECTRICAL CHARACTERISTICS (continued)

4.5 V < V_{CC} < 5.25 V, 8 V < V_s < 18 V, -40°C < T_J < 150°C; unless otherwise noted.

Symbol	Parameter	Test Conditions	Min	Typ	Max	Unit
CURRENT SENSE MONITOR OUTPUT ISOUT/PWM2						
Vis	Current Sense output functional voltage range	V _{CC} = 5 V, V _s = 8–20 V	0		V _{CC} - 0.5	V
Kis	Current Sense output ratio OUT1/4	K = I _{out} / I _{is} , 0 V ≤ V _{is} ≤ 4.5 V, V _{CC} = 5 V		12000		
	Current Sense output ratio OUT9 and 5 (low on-resistance bulb mode)			10000		
	Current Sense output ratio OUT6 (low on-resistance bulb mode)			5000		
	Current Sense output ratio OUT7/8 and 5/6 (high on-resistance LED mode)			2000		
I _{is,acc} (Notes 6 and 7)	Current Sense output accuracy OUT1/4	0.3 V ≤ V _{is} ≤ 4.5 V, V _{CC} = 5 V I _{out1/4} = 0.5–2.9 A	-12.5% - 1% FS		12.5% + 1% FS	
	Current Sense output accuracy OUT5/6 (low on-resistance bulb mode)	0.3 V ≤ V _{is} ≤ 4.5 V, V _{CC} = 5 V I _{out5} = 0.5–1.3 A, I _{out6} = 0.25–0.65 A	-14% - 1% FS		14% + 1% FS	
	Current Sense output accuracy OUT5/6 (high on-resistance LED mode)	0.3 V ≤ V _{is} ≤ 4.5 V, V _{CC} = 5 V I _{out5,6} = 0.1–0.3 A	-14% - 1% FS		14% + 1% FS	
	Current Sense output accuracy OUT7/8	0.3 V ≤ V _{is} ≤ 4.5 V, V _{CC} = 5 V	-8% - 1.5% FS		8% + 1.5% FS	
	Current Sense output accuracy OUT9	0.3 V ≤ V _{is} ≤ 4.5 V, V _{CC} = 5 V I _{out9} = 0.5–5.9 A	-10% - 1.5% FS		10% + 1.5% FS	
t _{is_blank}	Current Sense blanking time	Blanking time after current sense selection or driver activation	50		65	μs
t _{is}	Current Sense settling time	0 V to FSR (full scale range)		230	265	μs

6. Current sense output accuracy = I_{sout} - I_{sout_ideal} relative to I_{sout_ideal}

7. FS (Full scale) = I_{outmax}/K_{is}

NCV7705(A), NCV7706

ELECTRICAL CHARACTERISTICS (continued)

4.5 V < V_{CC} < 5.25 V, 8 V < V_s < 18 V, -40°C < T_J < 150°C; unless otherwise noted.

Symbol	Parameter	Test Conditions	Min	Typ	Max	Unit
DIGITAL INPUTS CSB, SCLK, PWM1/2, SI						
V _{inl}	Input low level	V _{CC} = 5 V			0.3·V _{CC}	V
V _{inh}	Input high level	V _{CC} = 5 V	0.7·V _{CC}			V
V _{in_hyst}	Input hysteresis		500			mV
R _{csb_pu}	CSB pull-up resistor	V _{CC} = 5 V, 0 V < V _{csb} < 0.7·V _{CC}	30	120	250	kΩ
R _{sclk_pd}	SCLK pull-down resistor	V _{CC} = 5 V, V _{sclk} = 1.5 V	30	60	220	kΩ
R _{si_pd}	SI pull-down resistor	V _{CC} = 5 V, V _{si} = 1.5 V	30	60	220	kΩ
R _{pwm1_pd}	PWM1 pull-down resistor	V _{CC} = 5 V, V _{pwm1} = 1.5 V	30	60	220	kΩ
R _{pwm2_pd}	PWM2 pull-down resistor	V _{CC} = 5 V, V _{pwm2} = 1.5 V, current sense disabled	30	60	220	kΩ
I _{leak_isout}	Output leakage current	current sense enabled	-2		2	μA
C _{csb / sclk / pwm1/2}	Pin capacitance	0 V < V _{CC} < 5.25 V (Note 8)			10	pF

DIGITAL INPUTS CSB, SCLK, SI; TIMING

t _{sclk}	Clock period	V _{CC} = 5 V		1000		ns
t _{sclk_h}	Clock high time		115			ns
t _{sclk_l}	Clock low time		115			ns
t _{set_csb}	CSB setup time, CSB low before rising edge of SCLK		400			ns
t _{set_sclk}	SCLK setup time, SCLK low before rising edge of CSB		400			ns
t _{set_si}	SI setup time		200			ns
t _{hold_si}	SI hold time		200			ns
t _{r_in}	Rise time of input signal SI, SCLK, CSB				100	ns
t _{f_in}	Fall time of input signal SI, SCLK, CSB				100	ns
t _{csb_hi_stdby}	Minimum CSB high time, switching from Standby mode	Transfer of SPI-command to input register, valid before t _{sact} mode transition delay expires		5	10	μs
t _{csb_hi_min}	Minimum CSB high time, Active mode			2	4	μs

8. Values based on design and/or characterization.

NCV7705(A), NCV7706

ELECTRICAL CHARACTERISTICS (continued)

4.5 V < V_{CC} < 5.25 V, 8 V < V_s < 18 V, -40°C < T_J < 150°C; unless otherwise noted.

Symbol	Parameter	Test Conditions	Min	Typ	Max	Unit
Vsol	Output low level	I _{so} = 5 mA			0.2·V _{CC}	V
Vsoh	Output high level	I _{so} = -5 mA	0.8·V _{CC}			V
Ileak_so	Tristate leakage current	V _{csb} = V _{CC} , 0 V < V _{so} < V _{CC}	-10		10	μA
Cso	Tristate input capacitance	V _{csb} = V _{CC} , 0 V < V _{CC} < 5.25 V (Note 8)			10	pF

DIGITAL OUTPUT SO; TIMING

tr_so	SO rise time	C _{so} = 100 pF		80	140	ns
tf_so	SO fall time	C _{so} = 100 pF		50	100	ns
ten_so_tril	SO enable time from tristate to low level	C _{so} = 100 pF, I _{load} = 1 mA, pull-up load to V _{CC}		100	250	ns
tdis_so_ltri	SO disable time from low level to tristate	C _{so} = 100 pF, I _{load} = 4 mA, pull-up load to V _{CC}		380	450	ns
ten_so_trih	SO enable time from tristate to high level	C _{so} = 100 pF, I _{load} = -1 mA, pull-down load to GND		100	250	ns
tdis_so_htri	SO disable time from high level to tristate	C _{so} = 100 pF, I _{load} = -4 mA, pull-down load to GND		380	450	ns
td_so	SO delay time	V _{so} < 0.3·V _{CC} , or V _{so} > 0.7·V _{CC} , C _{so} = 100 pF		50	250	ns

8. Values based on design and/or characterization.

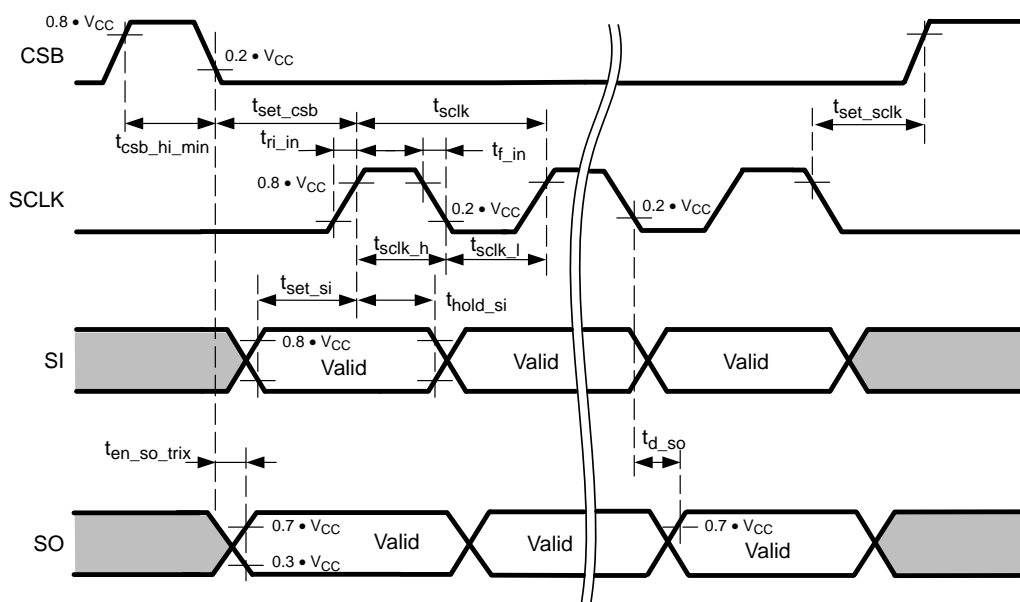

Figure 4. SPI Signals Timing Parameters

NCV7705(A), NCV7706

ELECTRICAL CHARACTERISTICS (continued)

4.5 V < V_{CC} < 5.25 V, 8 V < V_s < 18 V, -40°C < T_J < 150°C; unless otherwise noted.

Symbol	Parameter	Test Conditions	Min	Typ	Max	Unit
--------	-----------	-----------------	-----	-----	-----	------

THERMAL PROTECTION

Tjtw_on	Temperature warning threshold	Junction temperature	140		160	°C
Tjtw_hys	Thermal warning hysteresis			5		°C
Tjtd_on	Thermal shutdown threshold, T _J increasing	Junction temperature	160		180	°C
Tjtd_off	Thermal shutdown threshold, T _J decreasing	Junction temperature	160			°C
Tjtd_hys	Thermal shutdown hysteresis			5		°C
Tjsdtw_delta	Temperature difference between warning and shutdown threshold			20		°C
td_tx	Filter time for thermal warning and shutdown	TW / TSD Global Status bits	10		100	μs

OPERATING MODES TIMING

tact	Time delay for mode change from Unpowered mode into Standby mode	SPI communication ready after V _{CC} reached V _{UV_VCC(off)} threshold			30	μs
tsact	Time delay for mode change from Standby mode into Active mode	Time until output drivers are enabled after CSB going to high and CONTROL_0.MODE = 1		210	400	μs
tacts	Time delay for mode change from Active mode into Standby mode via SPI	Time until output drivers are disabled after CSB going to high and CONTROL_0.MODE = 0			300	μs

INTERNAL PWM CONTROL UNIT (OUT5 – OUT8)

PWMlo	PWM frequency, low selection	CONTROL_2.PWMI = 1, PWMx.FSELx = 0	135	170	200	Hz
PWMhi	PWM frequency, high selection	CONTROL_2.PWMI = 1, PWMx.FSELx = 1	175	225	260	Hz

Product parametric performance is indicated in the Electrical Characteristics for the listed test conditions, unless otherwise noted. Product performance may not be indicated by the Electrical Characteristics if operated under different conditions.

DETAILED OPERATING AND PIN DESCRIPTION

General

The NCV7705/NCV7706 provides four half-bridge drivers, five independent high-side outputs and a programmable PWM control unit for free configuration. Strict adherence to integrated circuit die temperature is necessary, with a static maximum die temperature of 150°C. This may limit the number of drivers enabled at one time. Output drive control and fault reporting are handled via the SPI (Serial Peripheral Interface) port. A SPI-controlled mode control provides a low quiescent sleep current mode when the device is not being utilized. A pull down is provided on the SI and SCLK inputs to ensure they default to a low state in the event of a severed input signal. A pull-up is provided on the CSB input disabling SPI communication in the event of an open CSB input.

Supply Concept

Power Supply Scheme – VS and VCC

The VS power supply voltage is used to supply the half bridges and the high-side drivers. An all-internal chargepump is implemented to provide the gate-drive voltage for the n-channel type high-side transistors. The VCC voltage is used to supply the logic section of the IC, including the SPI interface.

Due to the independent logic supply voltage the control and status information will not be lost in case of a loss of VS supply voltage. The device is designed to operate inside the specified parametric limits if the VCC supply voltage is within the specified voltage range (4.5 V to 5.25 V). Between the operational level and the VCC undervoltage threshold level (Vuv_VCC) it is guaranteed that the device remains in a safe functional state without any inadvertent change to logic information.

Device / Module Ground Concept

The high-side output stages OUT5–9 are designed to handle DC output voltage conditions down to –0.3 V and allow for short negative transient currents due to parasitic line inductances. Therefore the application has to take care that these ratings are not violated under abnormal operating conditions (module loss of GND, ground shift if load connected to external GND) by either implementing external bypass diodes connected to GND or a direct connection between load-GND and module-GND. Since these output stages are designed to drive resistive loads, restrictions on maximum inductance / clamping energy apply.

The heat slug is not hard-connected to internal GND rail. It has to be connected externally.

Power Up/Down Control

In order to prevent uncontrolled operation of the device during power/up down, an undervoltage lockout feature is implemented. Both supply voltages (VCC and VS) are

monitored for undervoltage conditions supporting a safe power-up transition. When VS drops below the undervoltage threshold Vuv_vs(off) (VS undervoltage threshold) all output stages are switched to high-impedance state and the global status bit UOV_OC is set. This bit is a multi information bit in the Global Status Byte which is set in case of overcurrent, VS over- and undervoltage. In case of undervoltage the status bit STATUS_2.VSUV is set, too.

Bit CONTROL_3.OVUVR (VS under-/overvoltage recovery behavior) can be used to select the desired recovery behavior after a VS under-voltage event. In case of OVUVR = 0, all output stages return to their programmed state as soon as VS recovers back to its normal operating range. If OVUVR is set, the automatic recovery function is disabled thus the output stages will remain in high-impedance condition until the status bits have been cleared by the microcontroller. To avoid high current oscillations in case of output short to GND and low VS voltage conditions, it is recommended to disable the VS-auto-recovery by setting OVUVR = 1.

Chargepump

In Standby mode, the chargepump is disabled. After enabling the device by setting bit CONTROL_0.MODE to active (1), the internal oscillator is started and the voltage at the CHP output pin begins to increase. The output drivers are enabled after a delay of tsact once MODE was set to active.

Driver Outputs

Output PWM Control

For all half-bridge outputs as well as the HS output OUT9 the device features the possibility to logically combine the SPI-setting with a PWM signal that can be provided to the inputs PWM1 and ISOUT/PWM2, respectively. Each of the outputs has a fixed PWM signal assigned which is shown in Table 1. The PWM modulation is enabled by the respective bits in the control registers (CONTROL_2.OUTx_PWMx and CONTROL_3.OUTx_PWMx). In case of using pin ISOUT/PWM2, the application design has to take care of either disabling the current sense feature or to provide sufficient overdrive capability to maintain proper logic input levels for the PWM input.

In addition to the external signal control, all lighting outputs (OUT5–9) can also be PWM controlled via an internal PWM generator unit. While the PWM frequency can be individually selected between 170 Hz and 225 Hz thru bits PWMx.FSELx, the duty cycle can be programmed with 7 or 10-bits resolution PWMx.PW[6/9:0]. The selection between the different signal sources for these outputs is performed by programming bit CONTROL_2.PWMI. Default value is 0 (external signal source). The general principle of the PWM generation control scheme is shown in Figure 5.

freewheeling diode connected between GND and the corresponding output is required.

The low-side driver at ECFB does not feature any freewheeling diode or clamping structure to handle inductive loads.

Current Sensing

Current Sense Output / PWM2 Input (Bidirectional Pin ISOUT/PWM2)

The current sense output allows a more precise analysis of the actual state of the load rather than the basic detection of an under- or overload condition. The sense output provides an image of the actual load current at the selected high side driver transistor. The current monitor function is available for high current half-bridge outputs (OUT1 and OUT4), the high current high-side output (OUT9) as well as for the all bulb and LED outputs (OUT5–8).

The current sense ratio is fixed for the low resistance outputs OUT1/4/9 and OUT5/6 (bulb mode) to 1/12000 resp. 1/10000 and for the high ohmic outputs OUT7/8 and OUT5/6 (LED mode) to 1/2000. To prevent from false readouts, the signal at pin ISOUT is blanked after switching on the driver until correct settlement of the circuitry (> 65 μ s). Bits CONTROL_3.IS[3:0] are used to select the output to be multiplexed to the current sense output.

The NCV7705/NCV7706 provides a sample-and-hold functionality for the current sense output to enable precise and simple load current diagnostics even during PWM operation of the respective output. While in active high-side output state, the current provided at ISOUT reflects a (low-pass-filtered) image of the actual output current, the IS-output current is sampled and held constant as soon as the HS output transistor is commanded off via PWM (low-side or high-impedant on half-bridge outputs, high-impedant on HS-outputs). In case no previous current information is available in the Sample-and-hold stage (current sense channel changed while actual channel is commanded off) the sample stage is reset so that it reflects zero output current.

Electro Chromic Mirror (NCV7706 ONLY)

Controller for Electro-chromic Glass

The voltage of the electro-chromic element connected at pin ECFB can be controlled to a target value which is set by Control Register 1 (bits CONTROL_1.DAC[5:0]). Setting bit CONTROL_1.ECEN enables this function. At the same time OUT8 is enabled, regardless of its own control bit CONTROL_1.HS8 and the respective PWM setting. An on-chip differential amplifier is used to control an external logic-level N-MOS pass device that delivers the power to

the electro-chromic element. The target voltage at ECFB is binary coded with a selectable full scale range (bit CONTROL_2.FSR). The default clamping value for the output voltage (CONTROL_2.FSR = 0) is 1.2 V, by setting CONFIG_1.FSR to “1”, the maximum output voltage is 1.5 V. The resolution of the DAC output voltage is independent of the full-scale-range selection.

The charging of the mirror (positive slope) is determined by the positive slew rate of the transconductance amplifier and the compensation capacitor, while in case of capacitive loads, the negative slope is mainly determined by the current consumption thru the load and its capacitance. To allow fast settling time changing from higher to lower output voltage values, the device provides two modes of operation:

1. Fast discharge: When the target output voltage is set to 0 V and bit CONTROL_1.LS_ECFB is set, the voltage at pin ECFB is pulled to ground by a 1.6 Ω low-side switch.
2. PWM discharge: In case of PWM discharge being activated (CONFIG.ECM_LSPWM = 1 and CONTROL_1.LS_ECFB = 1) (Figure 6):
 - a. The circuit regulation starts in normal regulation. The DAC value is turned to new lower value.
 - b. If the loop is detected out of regulation for a time longer than t_{rec} (~3 ms), the ECON voltage is detected low (internal signal ECON_LOW = 1), the regulator is switched off (DAC voltage at 0) and the fast discharge transistor is activated for ~300 ms (t_{disc}). During this fast discharge, the ECON output is pulled low to prevent from shoot-thru currents.
 - c. At the end of the discharge pulse t_{disc} the fast discharge is switched off and the regulation loop is activated again (with DAC to the correct wanted value), so the loop goes back to step b.) and the ECON_LOW comparator is observed again. Before starting a discharge pulse, the ECLO and ECHI comparator data is latched.

The feedback loop out of regulation is monitored by comparing V(ECON) versus V(ECFB) and versus 400 mV. If the regulation is activated and ECON is below ECFB, or below 400 mV, then the loop is detected as out of regulation and internal signal ECON_LOW is made 1. By activating the PWM discharge feature, the overcurrent recovery function is automatically disabled, regardless of the setting in CONTROL_2.OC_ECFB.

NCV7705(A), NCV7706

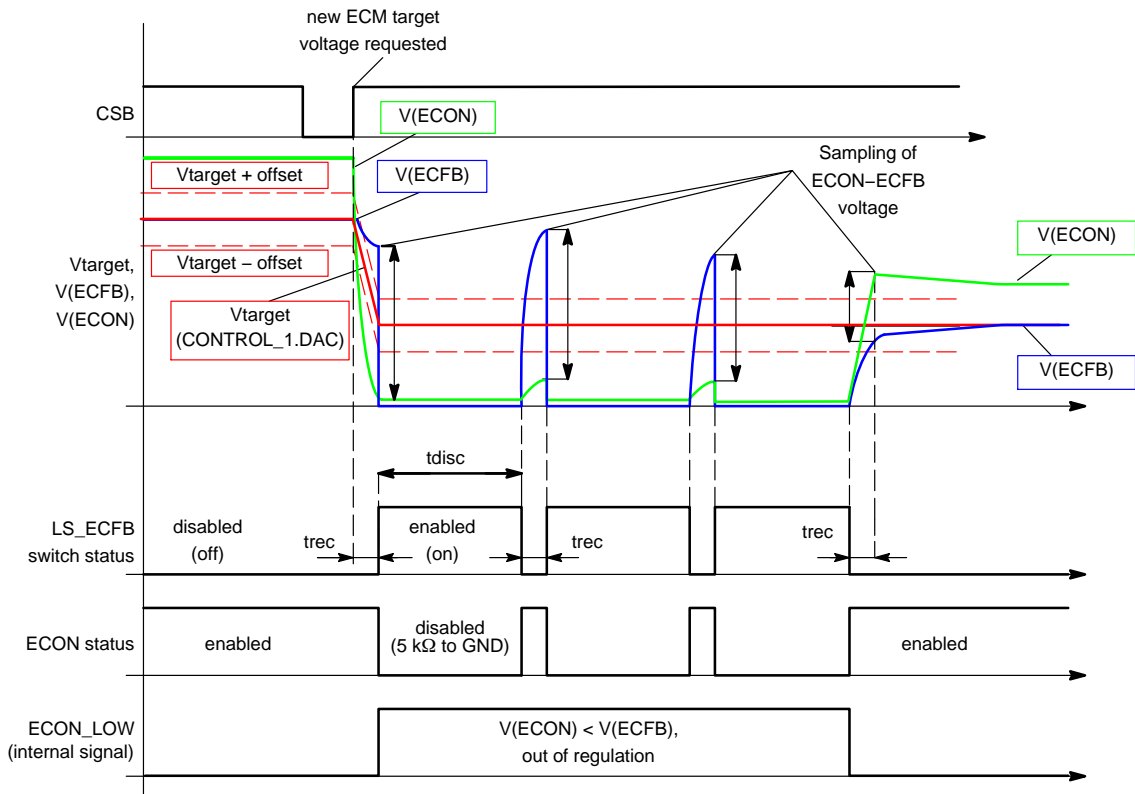

Figure 6. PWM Discharge Mode for ECFB

The controller provides a chip-internal diode from ECFB (Anode) to pin ECON (Cathode) to protect the external MOSFET. A capacitor of at least 4.7 nF has to be added to pin ECON for stability of the control loop. It is recommended to place 220 nF capacitor between ECFB and ground to increase the stability.

The status of the voltage control loop is reported via SPI. Bit STATUS_2.ECHI = 1 indicates that the voltage on ECFB is higher than the programmed target value, STATUS_2.ECLO = 1 indicates that the ECFB voltage is below the programmed value. Both status bits are valid if they are stable for at least 150 μs (settling time of the

regulation loop). If PWM discharge is enabled (CONFIG.ECM_LSPWM = 1), STATUS_2.ECHI is latched at the end of the discharge cycle, therefore if set it indicates that the device is in active discharge operation.

Since OUT8 is the output of a high-side driver, it contains the same diagnostic functions as the other high-side drivers (e.g. switch-off during overcurrent condition). In electro-chrome mode, OUT8 can't be controlled by PWM. For noise immunity reasons, it is recommended to place the loop capacitors at ECON as well as another capacitor between ECFB and GND as close as possible to the respective pins.

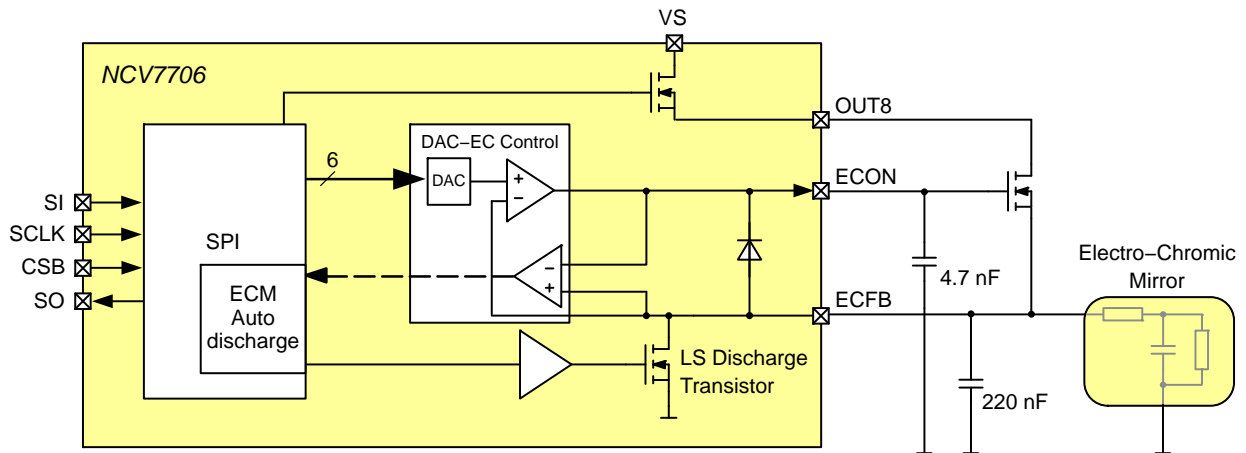

Figure 7. Electro Chromic Mirror Application Diagram

Diagnostic Functions

All diagnostic functions (overcurrent, underload, power supply monitoring, thermal warning and thermal shutdown) are internally filtered. The failure condition has to be valid for the minimum specified filtering time (td_{old} , td_{uld} , td_{uvov} and td_{tx}) before the corresponding status bit in the status register is set. The filter function is used to improve the noise immunity of the device. The undercurrent and temperature warning functions are intended for information purpose and do not affect the state of the output drivers. An overcurrent condition disables the corresponding output driver while a thermal shutdown event disables all outputs into high impedance state. Depending on the setting of the overcurrent recovery bits in the input register, the driver can either perform an auto-retry or remain latched off until the microcontroller clears the corresponding status bits. Overtemperature shutdown is latch-off only, without auto-retry functionality.

Overvoltage / Undervoltage Shutdown

If the supply voltage V_s rises above the switch off voltage $V_{ov_vs(off)}$ or falls below $V_{uv_vs(off)}$, all output transistors are switched to high-impedance state and the global status bit UOV_OC (multi information) is set. The status flag $STATUS_2.VSOV$, resp. $STATUS_2.VSUV$ is set, too, to log the over-/under-voltage event. The bit $CONTROL_3.OVUVR$ can be used to determine the recovery behavior once the V_s supply voltage gets back into the specified nominal operating range. $OVUVR = 0$ enables auto-recovery, with $OVUVR = 1$ the output stages remain in high impedance condition until the status flags have been cleared. Once set, $STATUS2.VSOV / VSUV$ can only be reset by a read&clear access to the status register $STATUS_2$.

Thermal Warning and Overtemperature Shutdown

The device provides a dual-stage overtemperature protection. If the junction temperature rises above T_{jtw_on} , a temperature warning flag (TW) is set in the Global Status Byte and can be read via SPI. The control software can then react onto this overload condition by a controlled disable of individual outputs. If however the junction temperature reaches the second threshold T_{jtd_on} , the thermal shutdown bit TSD is set in the Global Status Byte and all output stages are switched into high impedance state to protect the device. The minimum shutdown delay for overtemperature is td_{tx} . The output channels can be re-enabled after the device cooled down and the TSD flag has been reset by the microcontroller by setting $CONTROL_0.MODE = 0$.

Openload (Underload) Detection

The openload detection monitors the load current in the output stage while the transistor is active. If the load current is below the openload detection threshold for at least td_{uld} , the corresponding bit (ULD_x) is set in the status registers $STATUS_1/2$. The status of the output remains unchanged. Once set, ULD_x remains set regardless of the actual load condition. It has to be reset by a read&write access to the corresponding status register.

Overload Detection

An overcurrent condition is indicated by the flag (UOV_OC) in the Global Status Byte after a filter time of at least td_{old} . The channel dependent overcurrent flags are set in the status registers ($STATUS_0/2.OC_x$) and the corresponding driver is switched into high impedance state to protect the device. Each low-side and high-side driver stage provides its own overcurrent flag. Resetting this overcurrent flag automatically re-enables the respective output (provided it is still enabled thru the Control register). If the over current recovery function is enabled, the internal chip logic automatically resets the overcurrent flag after a fixed delay time, generating a PWM modulated current with a programmable duty cycle. Otherwise the status bits have to be cleared by the microcontroller by a read&clear access to the corresponding status register.

Cross-current Protection

All six half-bridges are protected against cross-currents by internal circuitry. If one driver is turned off (LS or HS), the activation of the other driver of the same output will be automatically delayed by the cross current protection mechanism until the active driver is safely turned off.

Mode Control

Wake-up and Mode Control

Two different modes are available:

- Active mode
- Standby mode

After power-up of VCC the device starts in Standby mode. Pulling the chip-select signal CSB to low level causes the device to change into Active mode (analog part active).

After at least 10 μs delay, the first SPI communication is valid and bit $CONTROL_0.MODE$ can be used to set the desired mode of operation. If bit $MODE$ remains reset (0) or CSB remains low longer than $t_{csb_low_stdby}$, the device returns to the Standby mode after an internal delay of max. 8 μs , clearing all register content and setting all output stages into high impedance state.

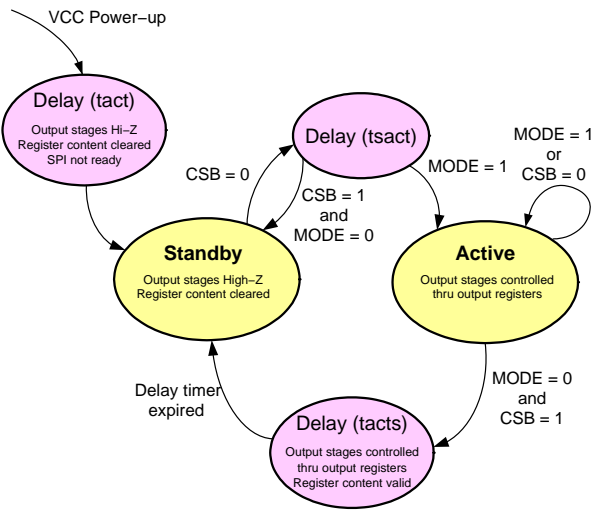

Figure 8. Mode Transitions Diagram

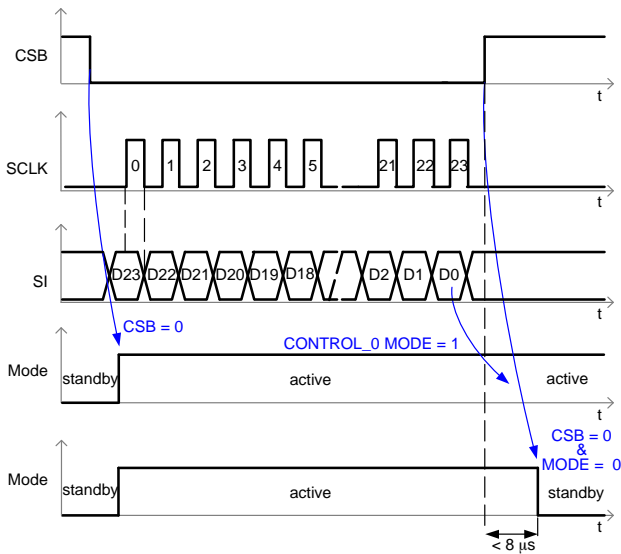

Figure 9. Mode Timing Diagram

SPI Control

General Description

The 4-wire SPI interface establishes a full duplex synchronous serial communication link between the NCV7705/NCV7706 and the application's microcontroller. The NCV7705/NCV7706 always operates in slave mode whereas the controller provides the master function. A SPI access is performed by applying an active-low slave select signal at CSB. SI is the data input, SO the data output. The SPI master provides the clock to the NCV7705/NCV7706 via the SCLK input. The digital input data is sampled at the rising edge at SCLK. The data output SO is in high impedance state (tri-state) when CSB is high. To readout the global error flag without sending a complete SPI frame, SO indicates the corresponding value as soon as CSB is set to active. With the first rising edge at SCLK after the high-to-low transition of CSB, the content of the selected register is transferred into the output shift register.

The NCV7705/NCV7706 provides four control registers (CONTROL_0/1/2/3), two PWM configuration registers (PWM_7/8 and PWM_9/10), three status registers (STATUS_0/1/2) and one general configuration register (CONFIG). Each of these register contains 16-bit data, together with the 8-bit frame header (access type, register address), the SPI frame length is therefore 24 bits. In addition to the read/write accessible registers, the NCV7705/NCV7706 provides five 8-bit ID registers (ID_HEADER, ID_VERSION, ID_CODE1/2 and ID_SPI-FRAME) with 8-bit data length. The content of these registers can still be read out by a 24-bit access, the data is then transferred in the MSB section of the data frame.

SPI Frame Format

Figure 10 shows the general format of the NCV7705/NCV7706 SPI frame.

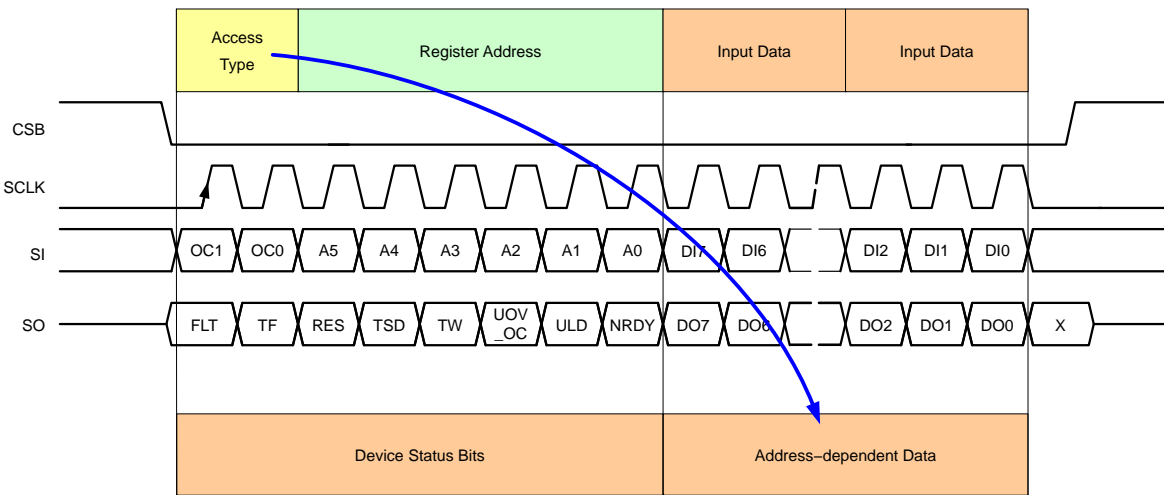

Figure 10. SPI Frame Format

24-bit SPI Interface

Both 24-bit input and output data are MSB first. Each SPI-input frame consists of a command byte followed by two data bytes. The data returned on SO within the same frame always starts with the global status byte. It provides general status information about the device. It is then followed by 2 data bytes (in-frame response) which content depends on the information transmitted in the command byte. For write access cycles, the global status byte is followed by the previous content of the addressed register.

Chip Select Bar (CSB)

CSB is the SPI input pin which controls the data transfer of the device. When CSB is high, no data transfer is possible and the output pin SO is set to high impedance. If CSB goes low, the serial data transfer is allowed and can be started. The communication ends when CSB goes high again.

Serial Clock (SCLK)

If CSB is set to low, the communication starts with the rising edge of the SCLK input pin. At each rising edge of SCLK, the data at the input pin Serial IN (SI) is latched. The data is shifted out thru the data output pin SO after the falling edges of SCLK. The clock SCLK must be active only within the frame time, means when CSB is low. The correct transmission is monitored by counting the number of clock pulses during the communication frame. If the number of SCLK pulses does not correspond to the frame width indicated in the SPI-frame-ID (Chip ID Register, address 3Eh) the frame will be ignored and the communication failure bit “TF” in the global status byte will be set. Due to this safety functionality, daisy chaining the SPI is not possible. Instead, a parallel operation of the SPI bus by controlling the CSB signal of the connected ICs is recommended.

Serial Data In (SI)

During the rising edges of SCLK (CSB is low), the data is transferred into the device thru the input pin SI in a serial

way. The device features a stuck-at-one detection, thus upon detection of a command = FFFFFFFh, the device will be forced into the Standby mode. All output drivers are switched off.

Serial Data Out (SO)

The SO data output driver is activated by a logical low level at the CSB input and will go from high impedance to a low or high level depending on the global status bit, FLT (Global Error Flag). The first rising edge of the SCLK input after a high to low transition of the CSB pin will transfer the content of the selected register into the data out shift register. Each subsequent falling edge of the SCLK will shift the next bit thru SO out of the device.

Command Byte / Global Status Byte

Each communication frame starts with a command byte (Table 2). It consists of an operation code (OP[1:0], Table 3) which specifies the type of operation (Read, Write, Read & Clear, Readout Device Information) and a six bit address (A[5:0], Table 4). If less than six address bits are required, the remaining bits are unused but are reserved. Both Write and Read mode allow access to the internal registers of the device. A “Read & Clear”-access is used to read a status register and subsequently clear its content. The “Read Device Information” allows to read out device related information such as ID-Header, Product Code, Silicon Version and Category and the SPI-frame ID. While receiving the command byte, the global status byte is transmitted to the microcontroller. It contains global fault information for the device, as shown in Table 6.

ID Register

Chip ID Information is stored in five special 8-bit ID registers (Table 5). The content can be read out at the beginning of the communication.

Table 2. COMMAND BYTE / GLOBAL STATUS BYTE STRUCTURE

Bit	Command Byte (IN) / Global Status Byte (OUT)							
	23	22	21	20	19	18	17	16
NCV7705/06 IN	OP1	OP0	A5	A4	A3	A2	A1	A0
NCV7705/06 OUT	FLT	TF	RESB	TSD	TW	UOV_OC	ULD	NRDY
Reset Value	1	0	0	0	0	0	0	1

Table 3. COMMAND BYTE, ACCESS MODE

OP1	OP0	Description
0	0	Write Access (W)
0	1	Read Access (R)
1	0	Read and Clear Access (RC)
1	1	Read Device ID (RDID)

NCV7705(A), NCV7706

Table 4. COMMAND BYTE, REGISTER ADDRESS

A[5:0]	Access	Description	Content
00h	R/W	Control Register CONTROL_0	Device mode control, Bridge outputs control
01h	R/W	Control Register CONTROL_1	High-side outputs control, ECM control (NCV7706 only)
02h	R/W	Control Register CONTROL_2	Bridge outputs recovery control, PWM enable, ECM setup (NCV7706 only)
03h	R/W	Control Register CONTROL_3	High-side outputs recovery control, PWM enable, Current Sense selection
08h	R/W	PWM Control Register PWM_5/6	PWM control register for OUT5/6 (7b control only)
09h	R/W	PWM Control Register PWM_7/8	PWM control register for OUT7/8 (7b control only)
10h	R/RC	Status Register STATUS_0	Bridge outputs Overcurrent diagnosis
11h	R/RC	Status Register STATUS_1	Bridge outputs Underload diagnosis
12h	R/RC	Status Register STATUS_2	HS outputs Overcurrent and Underload diagnosis, Vs Over- and Under-voltage, EC-mirror
13h	R/W	PWM Control Register PWM_5	PWM control register for OUT5 (10b control only)
14h	R/W	PWM Control Register PWM_6	PWM control register for OUT6 (10b control only)
15h	R/W	PWM Control Register PWM_7	PWM control register for OUT7 (10b control only)
16h	R/W	PWM Control Register PWM_8	PWM control register for OUT8 (10b control only)
3Fh	R/W	Configuration Register CONFIG	Mask bits for global fault bits

Table 5. CHIP ID INFORMATION

A[5:0]	Access	Description	Content
00h	RDID	ID header	4300h
01h	RDID	Version	0001h (NCV7705, NCV7706) 0004h (NCV7705A)
02h	RDID	Product Code 1	7700h
03h	RDID	Product Code 2	0500h (NCV7705) 0600h (NCV7706)
3Eh	RDID	SPI-Frame ID	0200h

NCV7705(A), NCV7706

Table 6. GLOBAL STATUS BYTE CONTENT

FLT		Global Fault Bit
0	No fault Condition	Failures of the Global Status Byte, bits [6:0] are always linked to the Global Fault Bit FLT. This bit is generated by an OR combination of all failure bits of the device (RESB inverted). It is reflected via the SO pin while CSB is held low and NO clock signal is present (before first positive edge of SCLK). The flag will remain valid as long as CSB is held low. This operation does not cause the Transmission error Flag in the Global Status Byte to be set. Signals TW and ULD can be masked.
1	Fault Condition	
TF		SPI Transmission Error
0	No Error	If the number of clock pulses within the previous frame was unequal 0 (FLT polling) or 24. The frame was ignored and this flag was set.
1	Error	
RESB		Reset Bar (Active low)
0	Reset	Bit is set to "0" after a Power-on-Reset or a stuck-at-1 fault at SI (SPI-input data = FFFFFFFh) has been detected. All outputs are disabled.
1	Normal Operation	
TSD		Overtemperature Shutdown
0	No Thermal Shutdown	Thermal Shutdown Status indication. In case of a Thermal Shutdown, all output drivers including the charge pump output are deactivated (high impedance). The TSD bit has to be cleared thru a SW reset to reactivate the output drivers and the chargepump output.
1	Thermal Shutdown	
TW		Thermal Warning
0	No Thermal Warning	This bit indicates a pre-warning level of the junction temperature. It is maskable by the Configuration Register (CONFIG.NO_TW).
1	Thermal Warning	
UOV_OC		VS Monitoring, Overcurrent Status
0	No Fault	This bit represents a logical OR combination of under-/overvoltage signals (VS) and overcurrent signals.
1	Fault	
ULD		Underload
0	No Underload	This bit represents a logical OR combination of all underload signals. It is maskable by the Configuration Register (CONFIG.NO_ULDX). It is also possible to deactivate this flag for HS1 or LS1, only (CONFIG.NO_ULD_HS1/LS1).
1	Underload	
NRDY		Not Ready
0	Device Ready	After transition from Standby to Active mode, an internal timer is started to allow the internal chargepump to settle before any outputs can be activated. This bit is cleared automatically after the startup is completed.
1	Device Not Ready	

NCV7705(A), NCV7706

SPI REGISTERS CONTENT

CONTROL_0 Register

Address: 00h

Bit	D15	D14	D13	D12	D11	D10	D9	D8	D7	D6	D5	D4	D3	D2	D1	D0
Access type	RW	RW	RW	RW	RW	RW	–	–	–	–	RW	RW	–	–	–	RW
Bit name	HS1	LS1	HS2	LS2	HS3	LS3	0	0	0	0	HS4	LS4	0	0	0	MODE
Reset value	0	0	0	0	0	0	0	0	0	0	0	0	0	0	0	0

	HSx	LSx		Description	Remark
HS/LS Outputs OUT1–4 Driver Control	0	0	default	OUTx High impedance	If a driver is enabled by the control register AND the corresponding PWM enable bit is set in CONTROL_2 register, the output is only activated if PWM1 (PWM2) input signal is high. Since OUT1..OUT4 are half-bridge outputs, activating both HS and LS at the same time is prevented by internal logic.
	0	1		LSx enabled	
	1	0		HSx enabled	
	1	1		OUTx High impedance	

	MODE		Description	Remark
Mode Control	0	default	Standby	If MODE is set, the device is switched to Active mode. Resetting MODE forces the device to transition into Standby mode, all internal memory is cleared and all output stages are switched into their default state (off). Delay of tacts should be respected before the Active mode is requested again.
	1		Active	

NCV7705(A), NCV7706

CONTROL_1 Register

Address: 01h

NCV7705:

Bit	D15	D14	D13	D12	D11	D10	D9	D8	D7	D6	D5	D4	D3	D2	D1	D0
Access type	RW	RW	RW	RW	RW	RW	RW	RW	RW	RW	RW	RW	RW	RW	RW	–
Bit name	HS5.1	HS5.0	HS6.1	HS6.0	HS7	HS8	HS9	LS ECFB	DAC5	DAC4	DAC3	DAC2	DAC1	DAC0	ECEN	0
Reset value	0	0	0	0	0	0	0	0	0	0	0	0	0	0	0	0

NCV7706:

Bit	D15	D14	D13	D12	D11	D10	D9	D8	D7	D6	D5	D4	D3	D2	D1	D0
Access type	RW	RW	RW	RW	RW	RW	RW	–	–	–	–	–	–	–	–	–
Bit name	HS5.1	HS5.0	HS6.1	HS6.0	HS7	HS8	HS9	0	0	0	0	0	0	0	0	0
Reset value	0	0	0	0	0	0	0	0	0	0	0	0	0	0	0	0

	HSx.1	HSx.0		Description	Remark
HS Outputs OUT5,6 Control	0	0	default	OUTx High impedance	If a driver is enabled by the control register AND the corresponding PWM enable bit is set in CONTROL_3 register, the output is only activated if the corresponding PWM input signal (PWM pin or internal PWM signal) is high.
	0	1		Output enabled, low current mode (LED mode)	
	1	0		Output enabled, high current mode (bulb mode)	
	1	1		OUTx High impedance	

	HSx		Description	Remark
HS Outputs OUT7–9 Control	0	default	OUTx High impedance	If a driver is enabled by the control register AND the corresponding PWM enable bit is set in CONTROL_3 register, the output is only activated if the corresponding PWM input signal (PWM pin or internal PWM signal) is high.
	1		OUTx enabled	

NCV7706 ONLY:

	LS ECFB		Description	Remark
ECFB Pull-down Output Control	0	default	Pull-down transistor disabled (high impedance)	The ECFB-pull-down transistor can only be activated if the DAC output voltage is set to 0 V (DAC[5:0]=0). If the PWM enable bit CONTROL_2.ECFB_PWM1 is set, the output will only be activated when the PWM1 signal input is high.
	1		Pull-down transistor enabled	

NCV7706 ONLY:

	DAC[5:0]		Description	Remark
Electrochrom. Mirror Reference Voltage	0	default	Reference voltage for ECON/ECFB differential amplifier	$V(DAC) = 1 + (1.5 / 2^6) \cdot DAC[5:0]$ If bit CONTROL_2.FSR=0, the output voltage is clamped to 1.2 V.
	n			

NCV7706 ONLY:

	ECEN		Description	Remark
Electrochrom. Mirror Enable	0	default	Electrochromic mirror controller disabled	By enabling the electrochromic mirror controller (ECEN=1), the output driver for the external pass transistor (ECON) is enabled. In addition, OUT8 is activated, regardless of the setting of CONTROL_1.HS8.
	1		Electrochromic mirror controller enabled	

NCV7705(A), NCV7706

CONTROL_2 Register

Address: 02h

NCV7705:

Bit	D15	D14	D13	D12	D11	D10	D9	D8	D7	D6	D5	D4	D3	D2	D1	D0
Access type	RW	RW	RW	–	–	RW	–	RW	RW	RW	RW	–	–	RW	–	–
Bit name	OCR1	OCR2	OCR3	0	0	OCR4	0	PWMI	OUT1 PWM1	OUT2 PWM1	OUT3 PWM1	0	0	OUT4 PWM1	0	0
Reset value	0	0	0	0	0	0	0	0	0	0	0	0	0	0	0	0

NCV7706:

Bit	D15	D14	D13	D12	D11	D10	D9	D8	D7	D6	D5	D4	D3	D2	D1	D0
Access type	RW	RW	RW	–	–	RW	RW	RW	RW	RW	RW	–	–	RW	RW	RW
Bit name	OCR1	OCR2	OCR3	0	0	OCR4	OCR ECFB	PWMI	OUT1 PWM1	OUT2 PWM1	OUT3 PWM1	0	0	OUT4 PWM1	ECFB PWM1	FSR
Reset value	0	0	0	0	0	0	0	0	0	0	0	0	0	0	0	0

	OCRx		Description	Remark
Overcurrent Recovery	0	default	Overcurrent Recovery disabled	During an overcurrent event the overcurrent status bit STATUS_0/2.OCx is set and the dedicated output is switched off. (The global multi bit UOV_OC is set, also). When the overcurrent recovery bit is enabled, the output will be reactivated automatically after a programmable delay time (CONTROL_3.OCRF).
	1		Overcurrent Recovery enabled	

	PWMI		Description	Remark
PWM Unit	0	default	Internal PWM unit disabled	The device has three different PWM sources: external pins PWM1, PWM2 and the internal PWM unit which can be used to control the lamp drivers in an additional way. PWMI selects the internal PWM unit.
	1		Internal PWM unit enabled	

	OUTx PWM		Description	Remark
PWM1/2 Selection	0	default	PWMx not selected	For the half-bridge outputs it is possible to select the PWM input pin PWM1. In this case the dedicated output (selected in CONTROL_0 register) is on if the PWM input signal is high. All half-bridges are controlled by PWM1.
	1		PWMx selected	

NCV7706 ONLY:

	FSR		Description	Remark
DAC Full-scale Range Control	0	default	$V_{out} = 1.5 / 2^6 \cdot DAC[5:0]$ clamped at 1.2 V	The default voltage at ECFB in electrochrome mode is clamped at 1.2 V, when FSR=1 the maximum value is 1.5 V.
	1		$V_{out} = 1.5 / 2^6 \cdot DAC[5:0]$	

NCV7705(A), NCV7706

CONTROL_3 Register

Address: 03h

Bit	D15	D14	D13	D12	D11	D10	D9	D8	D7	D6	D5	D4	D3	D2	D1	D0
Access Type	RW	RW	RW	RW	RW	RW	RW	RW	RW	RW	RW	RW	RW	RW	RW	RW
Bit name	OCR5	OCR6	OCR7	OCR8	OCR9	OUT5 PWM1	OUT6 PWM2	OUT7 PWM1	OUT8 PWM2	OUT9 PWM1	OCRF	OVUVR	IS3	IS2	IS1	IS0
Reset value	0	0	0	0	0	0	0	0	0	0	0	0	0	0	0	0

	OCRx		Description	Remark
Overcurrent Recovery	0	default	Overcurrent Recovery disabled	During an overcurrent event the overcurrent status bit STATUS_0/2.OCx is set and the dedicated output is switched off. (The global multi bit UOV_OC is set, also). When the overcurrent recovery bit is enabled, the output will be reactivated automatically after a programmable delay time (CONTROL_3.OCRF).
	1		Overcurrent Recovery enabled	

	OUTx PWM		Description	Remark
PWM1/2 Selection	0	default	PWMx not selected	For the HS outputs it is possible to select the PWM input pins PWM1, PWM2 or internal PWM1 unit (OUT5-8 only). In this case the dedicated output (selected in CONTROL_1 register) is on if the PWM input signal is high. OUT6 and OUT8 are controlled by PWM2, OUT5,7 and OUT9 are controlled by PWM1.
	1		PWMx selected	

	OCRF		Description	Remark
Overcurrent Recovery Frequency Selection	0	default	Slow Overcurrent recovery mode	If the overcurrent recovery bit is set, the output will be switched on automatically after a delay time. The recovery behavior of OUT5,6 in bulb mode is not affected by this bit.
	1		Fast Overcurrent recovery mode	

	OVUVR		Description	Remark
Over- / Under-voltage Recovery	0	default	Over- and undervoltage recovery function enabled	If the OV/UV recovery is disabled by setting OVUVR=1, the status register STATUS_2 bits VSOV or VSUV have to be cleared after an OV/UV event.
	1		No over- and undervoltage recovery	

NCV7705(A), NCV7706

Current Sensing Selection	IS3	IS2	IS1	IS0	Description	Remark
	0	0	0	0	OUT1	The current in all high-side power stages (except of OUT2/3) can be monitored at the bidirectional multifunctional pin ISOUT/PWM2. This pin is a multifunctional pin and can be activated as output by setting the current selection bits IS[3:0]. The selected high-side output will be multiplexed to the output ISOUT.
	0	0	0	1	current sensing deactivated	
	0	0	1	0	current sensing deactivated	
	0	0	1	1	current sensing deactivated	
	0	1	0	0	current sensing deactivated	
	0	1	0	1	OUT4	
	0	1	1	0	OUT5	
	0	1	1	1	OUT6	
	1	0	0	0	OUT7	
	1	0	0	1	OUT8	
	1	0	1	0	OUT9	
	1	0	1	1	current sensing deactivated	
	1	1	0	0	current sensing deactivated	
	1	1	0	1	current sensing deactivated	
	1	1	1	0	current sensing deactivated	
1	1	1	1	current sensing deactivated		

PWM_5/6 Register

Address: 08h

Bit	D15	D14	D13	D12	D11	D10	D9	D8	D7	D6	D5	D4	D3	D2	D1	D0
Access Type	RW	RW	RW	RW	RW	RW	RW	RW	RW	RW	RW	RW	RW	RW	RW	RW
Bit Name	FSEL5	PW5.6	PW5.5	PW5.4	PW5.3	PW5.2	PW5.1	PW5.0	FSEL6	PW6.6	PW6.5	PW6.4	PW6.3	PW6.2	PW6.1	PW6.0
Reset Value	0	0	0	0	0	0	0	0	0	0	0	0	0	0	0	0

PWM Duty Cycle selector for OUT5	PW5[6:0]		Description	Remark
	0	default	Duty Cycle for OUT5 = $(PW5[6:0] + 1) / 128$	It is possible to control OUT5 by the internal PWM unit if bit PWM1 is set in the control register CONTROL_2. If CONFIG.PWM_RESEN is set, OUT5 duty cycle is controlled by register PWM_5 with 10-bit resolution.
	1 .. 7Fh			

PWM Frequency selector for OUT5	FSEL5		Description	Remark
	0	default	$f(PWM) = 170 \text{ Hz}$	Bit FSEL5 selects between 170 and 225 Hz PWM frequency for OUT5.
	1		$f(PWM) = 225 \text{ Hz}$	

PWM Duty Cycle selector for OUT6	PW6[6:0]		Description	Remark
	0	default	Duty Cycle for OUT6 = $(PW6[6:0] + 1) / 128$	It is possible to control OUT6 by the internal PWM unit if bit PWM1 is set in the control register CONTROL_2. If CONFIG.PWM_RESEN is set, OUT6 duty cycle is controlled by register PWM_6 with 10-bit resolution.
	1 .. 7Fh			

PWM Frequency selector for OUT6	FSEL6		Description	Remark
	0	default	$f(PWM) = 170 \text{ Hz}$	Bit FSEL6 selects between 170 and 225 Hz PWM frequency for OUT6.
	1		$f(PWM) = 225 \text{ Hz}$	

NCV7705(A), NCV7706

PWM_7/8 Register

Address: 09h

Bit	D15	D14	D13	D12	D11	D10	D9	D8	D7	D6	D5	D4	D3	D2	D1	D0
Access Type	RW	RW	RW	RW	RW	RW	RW	RW	RW	RW	RW	RW	RW	RW	RW	RW
Bit Name	FSEL7	PW7.6	PW7.5	PW7.4	PW7.3	PW7.2	PW7.1	PW7.0	FSEL8	PW8.6	PW8.5	PW8.4	PW8.3	PW8.2	PW8.1	PW8.0
Reset Value	0	0	0	0	0	0	0	0	0	0	0	0	0	0	0	0

	PW7[6:0]		Description	Remark
PWM Duty Cycle selector for OUT7	0	default	Duty Cycle for OUT7 = (PW7[6:0] + 1) / 128	It is possible to control OUT7 by the internal PWM unit if bit PWMI is set in the control register CONTROL_2. If CONFIG.PWM_RESEN is set, OUT7 duty cycle is controlled by register PWM_7 with 10-bit resolution.
	1 .. 7Fh			

	FSEL7		Description	Remark
PWM Frequency selector for OUT7	0	default	f(PWM) = 170 Hz	Bit FSEL7 selects between 170 and 225 Hz PWM frequency for OUT7.
	1		f(PWM) = 225 Hz	

	PW8[6:0]		Description	Remark
PWM Duty Cycle selector for OUT8	0	default	Duty Cycle for OUT8 = (PW8[6:0] + 1) / 128	It is possible to control OUT8 by the internal PWM unit if bit PWMI is set in the control register CONTROL_2. If CONFIG.PWM_RESEN is set, OUT8 duty cycle is controlled by register PWM_8 with 10-bit resolution.
	1 .. 7Fh			

	FSEL8		Description	Remark
PWM Frequency selector for OUT8	0	default	f(PWM) = 170 Hz	Bit FSEL8 selects between 170 and 225 Hz PWM frequency for OUT8.
	1		f(PWM) = 225 Hz	

NCV7705(A), NCV7706

STATUS_0 Register

Address: 10h

Bit	D15	D14	D13	D12	D11	D10	D9	D8	D7	D6	D5	D4	D3	D2	D1	D0
Access Type	R/RC	R/RC	R/RC	R/RC	R/RC	R/RC	–	–	–	–	R/RC	R/RC	–	–	–	–
Bit Name	OC HS1	OC LS1	OC HS2	OC LS2	OC HS3	OC LS3	0	0	0	0	OC HS4	OC LS4	0	0	0	0
Reset Value	0	0	0	0	0	0	0	0	0	0	0	0	0	0	0	0

	OCx	Description	Remark
OUT1–4 Overcurrent Detection	0	No overcurrent detected	During an overcurrent event in one of the HS or LS, the belonging overcurrent status bit STATUS_0.OCx is set and the dedicated output is switched off. (The global multi bit UOV_OC is set, also). When the overcurrent recovery bit is enabled, the output will be reactivated automatically after a programmable delay time (CONTROL_3.OCRFB). If the overcurrent recovery bit is not set the microcontroller has to clear the OC failure bit and to reactivate the output stage again.
	1	Overcurrent detected	

STATUS_1 Register

Address: 11h

Bit	D15	D14	D13	D12	D11	D10	D9	D8	D7	D6	D5	D4	D3	D2	D1	D0
Access Type	R/RC	R/RC	R/RC	R/RC	R/RC	R/RC	–	–	–	–	R/RC	R/RC	–	–	–	–
Bit Name	ULD HS1	ULD LS1	ULD HS2	ULD LS2	ULD HS3	ULD LS3	0	0	0	0	ULD HS4	ULD LS4	0	0	0	0
Reset Value	0	0	0	0	0	0	0	0	0	0	0	0	0	0	0	0

	ULDx	Description	Remark
OUT1–4 Underload Detection	0	No underload detected	For each output stage an underload status bit ULD is available. The underload detection is done in “on-mode”. If the load current is below the undercurrent detection threshold for at least td_uld, the corresponding underload bit ULDx is set. If an ULD event occurs the global status bit ULD will be set. For ULD_HS1 and ULD_LS1 it is possible to deactivate the global ULD failure bit by setting the configuration bits CONFIG.NO_ULD_HS1/LS1. With setting CONFIG.NO_ULD_OUTn the global ULD failure bit is deactivated in general.
	1	Underload detected	

NCV7705(A), NCV7706

STATUS_2 Register

Address: 12h

NCV7705:

Bit	D15	D14	D13	D12	D11	D10	D9	D8	D7	D6	D5	D4	D3	D2	D1	D0
Access type	R/RC	R/RC	R/RC	R/RC	R/RC	R/RC	R/RC	R/RC	R/RC	R/RC	-	-	R/RC	R/RC	-	-
Bit name	OC HS5	ULD HS5	OC HS6	ULD HS6	OC HS7	ULD HS7	OC HS8	ULD HS8	OC HS9	ULD HS9	0	0	VSUV	VSOV	0	0
Reset value	0	0	0	0	0	0	0	0	0	0	0	0	0	0	0	0

NCV7706:

Bit	D15	D14	D13	D12	D11	D10	D9	D8	D7	D6	D5	D4	D3	D2	D1	D0
Access type	R/RC	R/RC	R/RC	R/RC	R/RC	R/RC	R/RC	R/RC	R/RC	R/RC	R/RC	R/RC	R/RC	R/RC	R/RC	R/RC
Bit name	OC HS5	ULD HS5	OC HS6	ULD HS6	OC HS7	ULD HS7	OC HS8	ULD HS8	OC HS9	ULD HS9	OC ECFB	ULD ECFB	VSUV	VSOV	ECLO	ECHI
Reset value	0	0	0	0	0	0	0	0	0	0	0	0	0	0	0	0

	OCx	Description	Remark
OUT5-9 Overcurrent Detection	0	No overcurrent detected	During an overcurrent event in one of the HS the belonging overcurrent status bit STATUS_2.OCx is set and the dedicated output is switched off. (The global multi bit UOV_OC is set, also). When the overcurrent recovery bit is enabled, the output will be reactivated automatically after a programmable delay time (CONTROL_3.OCRF). If the overcurrent recovery bit is not set the microcontroller has to clear the OC failure bit and to reactivate the output stage again.
	1	Overcurrent detected	

	ULDx	Description	Remark
OUT5-9 Underload Detection	0	No underload detected	For each output stage an underload status bit ULD is available. The underload detection is done in "on-mode". If the load current is below the undercurrent detection threshold for at least td_uld, the corresponding underload bit ULDx is set. If an ULD event occurs the global status bit ULD will be set. It is possible to deactivate the global ULD failure bit by setting the configuration bits CONFIG.NO_ULD_OUTn.
	1	Underload detected	

	VSUV	Description	Remark
Vs Undervoltage	0	No undervoltage detected	In case of an Vs undervoltage event, the output stages will be deactivated immediately and the corresponding failure flag will be set. By default the output stages will be reactivated automatically after Vs is recovered unless the control bit CONTROL_3.OVUVR is set. If this is the case (OVUVR=1) the bit VSUV has to be cleared after an UV event.
	1	Undervoltage detected	

	VSOV	Description	Remark
Vs Overvoltage	0	No overvoltage detected	In case of an Vs overvoltage event, the output stages will be deactivated immediately and the corresponding failure flag will be set. By default the output stages will be reactivated automatically after Vs is recovered unless the control bit CONTROL_3.OVUVR is set. If this is the case (OVUVR=1) the bit VSOV has to be cleared after an OV event.
	1	Overvoltage detected	

	ECLO	ECHI	Description	Remark
EC Mirror Control Status	0	0	ECM output regulation in range	Two comparators monitor the voltage at pin ECFB (feedback) in electrochrome mode. If this voltage is below / above the programmed target these bits signal the difference after at least 32 μs. The bits are not latched and may toggle after at least 32 μs, if the ECFB voltage has not yet reached the target. They are not assigned to the Global Error Flag.
	0	1	ECM output V > Vregulation	
	1	0	ECM output V < Vregulation	
	1	1	not used	

NCV7705(A), NCV7706

PWM_5 Register

Address: 13h

Bit	D15	D14	D13	D12	D11	D10	D9	D8	D7	D6	D5	D4	D3	D2	D1	D0
Access Type	RW	–	–	–	–	–	RW	RW	RW	RW	RW	RW	RW	RW	RW	RW
Bit Name	FSEL5	0	0	0	0	0	PW5.9	PW5.8	PW5.7	PW5.6	PW5.5	PW5.4	PW5.3	PW5.2	PW5.1	PW5.0
Reset Value	0	0	0	0	0	0	0	0	0	0	0	0	0	0	0	0

PWM Duty Cycle selector for OUT5	PW5[6:0]		Description	Remark
	0	default	Duty Cycle for OUT5 = (PW5[9:0] + 1) / 1024	It is possible to control OUT5 by the internal PWM unit with 10 bit resolution if bits CONTROL_2.PWMI and CONFIG.PWM_RESEN are set; PWM_5.PW5[9:0] is ignored otherwise.
	1 .. 7Fh			

PWM Frequency selector for OUT5	FSEL5		Description	Remark
	0	default	f(PWM) = 170 Hz	Bit FSEL5 selects between 170 and 225 Hz PWM frequency for OUT5.
	1		f(PWM) = 225 Hz	

PWM_6 Register

Address: 14h

Bit	D15	D14	D13	D12	D11	D10	D9	D8	D7	D6	D5	D4	D3	D2	D1	D0
Access Type	RW	–	–	–	–	–	RW	RW	RW	RW	RW	RW	RW	RW	RW	RW
Bit Name	FSEL6	0	0	0	0	0	PW6.9	PW6.8	PW6.7	PW6.6	PW6.5	PW6.4	PW6.3	PW6.2	PW6.1	PW6.0
Reset Value	0	0	0	0	0	0	0	0	0	0	0	0	0	0	0	0

PWM Duty Cycle selector for OUT6	PW6[6:0]		Description	Remark
	0	default	Duty Cycle for OUT6 = (PW6[9:0] + 1) / 1024	It is possible to control OUT6 by the internal PWM unit with 10 bit resolution if bits CONTROL_2.PWMI and CONFIG.PWM_RESEN are set; PWM_6.PW6[9:0] is ignored otherwise.
	1 .. 7Fh			

PWM Frequency selector for OUT6	FSEL6		Description	Remark
	0	default	f(PWM) = 170 Hz	Bit FSEL6 selects between 170 and 225 Hz PWM frequency for OUT6.
	1		f(PWM) = 225 Hz	

NCV7705(A), NCV7706

PWM_7 Register

Address: 15h

Bit	D15	D14	D13	D12	D11	D10	D9	D8	D7	D6	D5	D4	D3	D2	D1	D0
Access Type	RW	-	-	-	-	-	RW	RW	RW	RW	RW	RW	RW	RW	RW	RW
Bit Name	FSEL7	0	0	0	0	0	PW7.9	PW7.8	PW7.7	PW7.6	PW7.5	PW7.4	PW7.3	PW7.2	PW7.1	PW7.0
Reset Value	0	0	0	0	0	0	0	0	0	0	0	0	0	0	0	0

PWM Duty Cycle selector for OUT7	PW7[6:0]		Description	Remark
	0	default	Duty Cycle for OUT7 = (PW7[9:0] + 1) / 1024	It is possible to control OUT7 by the internal PWM unit with 10 bit resolution if bits CONTROL_2.PWMI and CONFIG.PWM_RESEN are set; PWM_7.PW7[9:0] is ignored otherwise.
	1 .. 7Fh			

PWM Frequency selector for OUT7	FSEL7		Description	Remark
	0	default	f(PWM) = 170 Hz	Bit FSEL7 selects between 170 and 225 Hz PWM frequency for OUT7.
	1		f(PWM) = 225 Hz	

PWM_8 Register

Address: 16h

Bit	D15	D14	D13	D12	D11	D10	D9	D8	D7	D6	D5	D4	D3	D2	D1	D0
Access Type	RW	-	-	-	-	-	RW	RW	RW	RW	RW	RW	RW	RW	RW	RW
Bit Name	FSEL8	0	0	0	0	0	PW8.9	PW8.8	PW8.7	PW8.6	PW8.5	PW8.4	PW8.3	PW8.2	PW8.1	PW8.0
Reset Value	0	0	0	0	0	0	0	0	0	0	0	0	0	0	0	0

PWM Duty Cycle selector for OUT8	PW8[9:0]		Description	Remark
	0	default	Duty Cycle for OUT8 = (PW8[9:0] + 1) / 1024	It is possible to control OUT8 by the internal PWM unit with 10 bit resolution if bits CONTROL_2.PWMI and CONFIG.PWM_RESEN are set; PWM_8.PW8[9:0] is ignored otherwise.
	1 .. 7Fh			

PWM Frequency selector for OUT8	FSEL8		Description	Remark
	0	default	f(PWM) = 170 Hz	Bit FSEL8 selects between 170 and 225 Hz PWM frequency for OUT8.
	1		f(PWM) = 225 Hz	

NCV7705(A), NCV7706

CONFIG Register

Address: 3Fh

NCV7705:

Bit	D15	D14	D13	D12	D11	D10	D9	D8	D7	D6	D5	D4	D3	D2	D1	D0
Access Type	-	RW	-	-	-	-	-	-	-	-	RW	RW	RW	-	RW	-
Bit Name	0	PWM RESEN	0	0	0	0	0	0	0	0	NO_ULD HS1	NO_ULD LS1	NO_TW	0	NO_ULD OUTn	0
Reset Value	0	0	0	0	0	0	0	0	0	0	0	0	0	0	0	0

NCV7706:

Bit	D15	D14	D13	D12	D11	D10	D9	D8	D7	D6	D5	D4	D3	D2	D1	D0
Access Type	-	RW	-	-	-	-	-	-	RW	-	RW	RW	RW	-	RW	-
Bit Name	0	PWM RESEN	0	0	0	0	0	0	ECM LSPWM	0	NO_ULD HS1	NO_ULD LS1	NO_TW	0	NO_ULD OUTn	0
Reset Value	0	0	0	0	0	0	0	0	0	0	0	0	0	0	0	0

	NO_ULD HS1	NO_ULD LS1		Description	Remark
Global Underload Flag HS1/LS1	0	0	default	Global underload flag at HS1/LS1 active	For ULD_HS1 and ULD_LS1 it is possible to deactivate the global ULD failure bit by setting the configuration bits CONFIG.NO_ULD_HS1/LS1. With setting CONFIG.NO_ULD_OUTn the global ULD failure bit is deactivated in general.
	0	1		No global underload flag at LS1	
	1	0		No global underload flag at HS1	
	1	1		No global underload flag at HS1/LS1	

	NO_TW		Description	Remark
No Thermal Warning Flag	0	default	Thermal warning flag active	The global thermal warning bit TW can be deactivated.
	1		No thermal warning flag active	

	NO_ULD_OUTn		Description	Remark
Global Underload Flag OUTn	0	default	Global underload flag active	By setting CONFIG.NO_ULD_OUTn the global ULD failure bit is deactivated in general.
	1		No global underload flag active	

NCV7706 ONLY:

	ECM_LSPWM		Description	Remark
ECM PWM Discharge	0	default	LS PWM feature disabled	If this bit is set, automatic PWM discharge on the ECM output is enabled. In case of PWM discharge the Overcurrent recovery feature is disabled, regardless of the setting of CONTROL_2.OC_ECFB.
	1		LS PWM feature enabled	

	PWM_RESEN		Description	Remark
Increased PWM Resolution	0	default	7 bits PWM	By default, 7 bits internal PWM resolution is used and duty cycle is controlled by registers PWM_5/6 and PWM_7/8. If this bit is set, 10 bits internal PWM resolution is used and duty cycle is controlled by registers PWM_5, PWM_6, PWM_7 and PWM_8.
	1		10 bits PWM	

onsemi, **Onsemi**, and other names, marks, and brands are registered and/or common law trademarks of Semiconductor Components Industries, LLC dba "**onsemi**" or its affiliates and/or subsidiaries in the United States and/or other countries. **onsemi** owns the rights to a number of patents, trademarks, copyrights, trade secrets, and other intellectual property. A listing of **onsemi**'s product/patent coverage may be accessed at www.onsemi.com/site/pdf/Patent-Marking.pdf. **onsemi** reserves the right to make changes at any time to any products or information herein, without notice. The information herein is provided "as-is" and **onsemi** makes no warranty, representation or guarantee regarding the accuracy of the information, product features, availability, functionality, or suitability of its products for any particular purpose, nor does **onsemi** assume any liability arising out of the application or use of any product or circuit, and specifically disclaims any and all liability, including without limitation special, consequential or incidental damages. Buyer is responsible for its products and applications using **onsemi** products, including compliance with all laws, regulations and safety requirements or standards, regardless of any support or applications information provided by **onsemi**. "Typical" parameters which may be provided in **onsemi** data sheets and/or specifications can and do vary in different applications and actual performance may vary over time. All operating parameters, including "Typicals" must be validated for each customer application by customer's technical experts. **onsemi** does not convey any license under any of its intellectual property rights nor the rights of others. **onsemi** products are not designed, intended, or authorized for use as a critical component in life support systems or any FDA Class 3 medical devices or medical devices with a same or similar classification in a foreign jurisdiction or any devices intended for implantation in the human body. Should Buyer purchase or use **onsemi** products for any such unintended or unauthorized application, Buyer shall indemnify and hold **onsemi** and its officers, employees, subsidiaries, affiliates, and distributors harmless against all claims, costs, damages, and expenses, and reasonable attorney fees arising out of, directly or indirectly, any claim of personal injury or death associated with such unintended or unauthorized use, even if such claim alleges that **onsemi** was negligent regarding the design or manufacture of the part. **onsemi** is an Equal Opportunity/Affirmative Action Employer. This literature is subject to all applicable copyright laws and is not for resale in any manner.

PUBLICATION ORDERING INFORMATION

LITERATURE FULFILLMENT:

Email Requests to: orderlit@onsemi.com

onsemi Website: www.onsemi.com

TECHNICAL SUPPORT

North American Technical Support:

Voice Mail: 1 800-282-9855 Toll Free USA/Canada

Phone: 011 421 33 790 2910

Europe, Middle East and Africa Technical Support:

Phone: 00421 33 790 2910

For additional information, please contact your local Sales Representative