

**10W STEREO CLASS-D AUDIO POWER AMPLIFIER**

**Description**

The PAM8006 is a 10W (per channel) stereo Class-D audio amplifier with fixed gain which offers low THD+N, low EMI, and good PSRR producing high-quality sound reproduction.

The PAM8006 runs off from a 7.5V to 18V supply at much higher efficiency than competitors' ICs.

The PAM8006 only requires very few external components, significantly saving cost and board space.

The PAM8006 is available in a 32pin QFN 5mm\*5mm and TSSOP-28PP package.

**Features**

- 10W @ 10%THD/ Channel Output into a 8Ω Load at 13V
- Power Supply Range: 7.5V to 18V
- Low SNR: 95dB
- Over 90% Efficiency
- With Shutdown/Mute Function
- Over Current , Thermal, Short-Circuit Protection and UVLO
- Low THD+N
- Low Quiescent Current
- Pop Noise Suppression
- Small Package Outlines: Thin 32-pin QFN 5mm\*5mm and TSSOP-28PP Package
- RoHS Pass and Green Package

**Applications**

- Flat Monitor /LCD TVs
- Multi-media Speaker System
- DVD players, Game machines
- Boom Box
- Music instruments

**Pin Assignments**

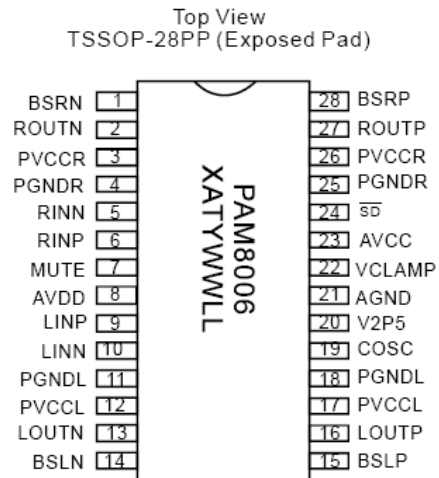
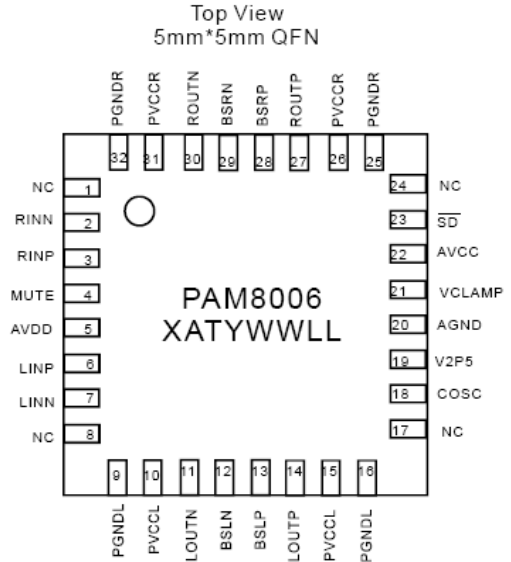

**Typical Applications Circuit**

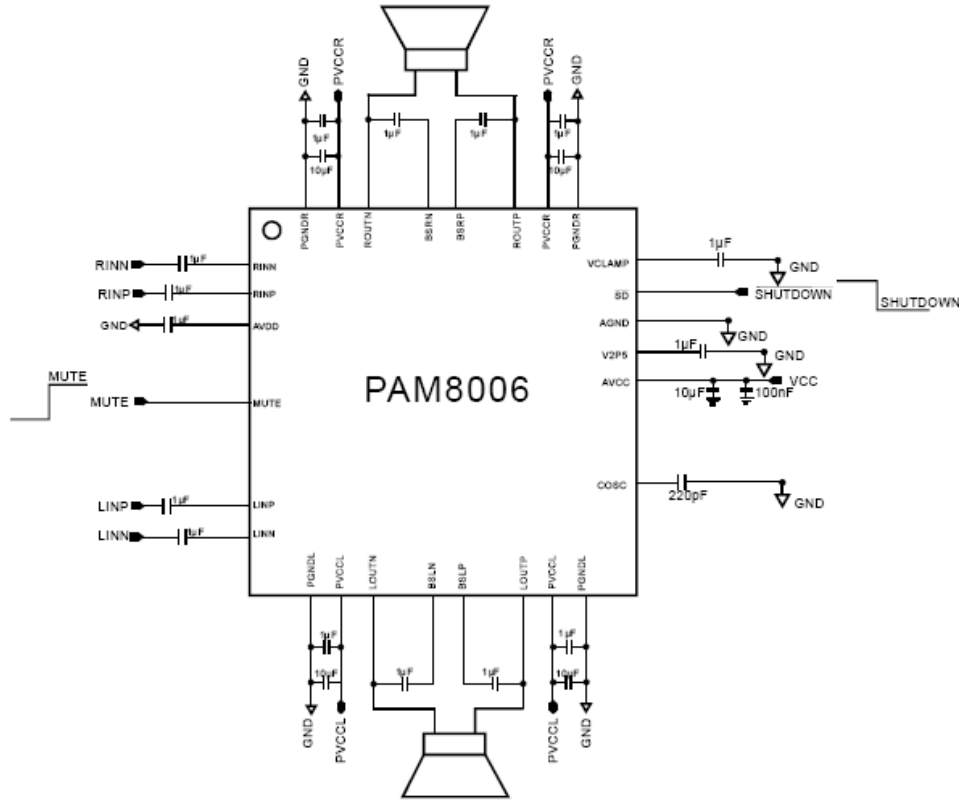

## Pin Descriptions

Pin Name	Pin Number		Function
	QFN5x5	TSSOP-25	
RINN	2	5	Negative differential audio input for right channel.
RINP	3	6	Positive differential audio input for right channel.
NC	1, 8, 17, 24	—	Not Connected
AVDD	5	8	5V Analog $V_{DD}$
MUTE	4	7	A logic high on this pin disables the outputs and a logic low enables the outputs.
LINP	6	9	Positive differential audio input for left channel.
LINN	7	10	Negative differential audio input for left channel.
PGNDL	9, 16	11, 18	Power ground for left channel H-bridge.
PVCCCL	10, 15	12, 17	Power supply for left channel H-bridge not connected to PVCCR or AVCC.
LOUTN	11	13	Class-D 1/2-H-bridge negative output for left channel.
BSLN	12	14	Bootstrap I/O for left channel, negative high-side FET.
BSLP	13	15	Bootstrap I/O for left channel, positive high-side FET.
LOUTP	14	16	Class-D 1/2-H-bridge positive output for left channel.
COSC	18	19	I/O for charge/discharging currents onto capacitor for ramp generator triangle wave biased at V2P5.
AVCC	22	23	High-voltage analog power supply (7.5V to 18V).
V2P5	19	20	2.5V Reference for analog cells, as well as reference for unused audio input when using single-ended inputs.
AGND	20	21	Analog GND
SD	23	24	Shutdown signal for IC (low = shutdown, high = operational). TTL logic levels with compliance to $V_{CC}$ .
VCLAMP	21	22	Internally generated voltage supply bootstrap capacitors.
PGNDR	25, 32	4, 25	Power ground for right channel H-bridge.
PVCCR	26, 31	3, 26	Power supply for right channel H-bridge not connected to PVCCCL or AVCC.
ROUTP	27	27	Class-D 1/2-H-bridge positive output for right channel.
BSRP	28	28	Bootstrap I/O for right channel, positive high-side FET.
BSRN	29	1	Bootstrap I/O for right channel, negative high-side FET.
POUTN	30	2	Class-D 1/2-H-bridge negative output for right channel.

**Functional Block Diagram**

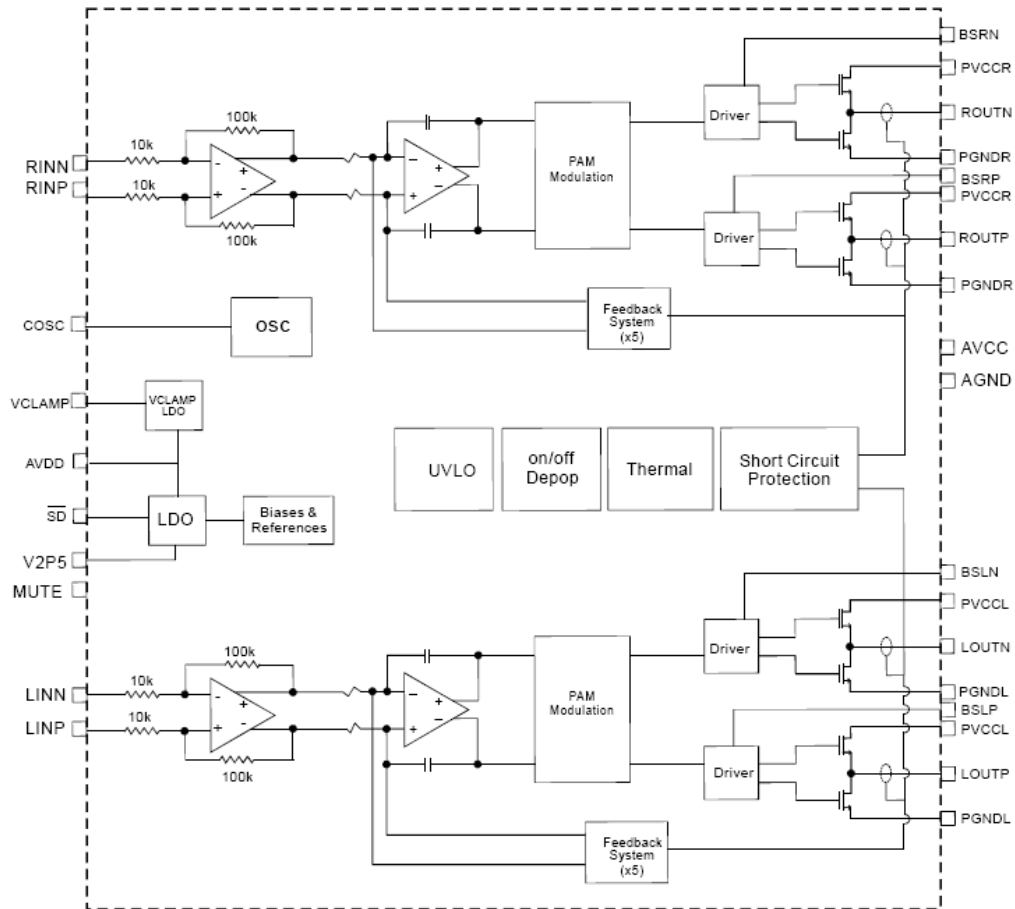

**Absolute Maximum Ratings** (@T<sub>A</sub> = +25°C, unless otherwise specified.)

These are stress ratings only and functional operation is not implied. Exposure to absolute maximum ratings for prolonged time periods may affect device reliability. All voltages are with respect to ground.

Parameter	Rating	Unit
Supply Voltage V <sub>CC</sub>	-0.3 to +20V	
Input Pin Voltage Range V <sub>I</sub> : MUTE	0 to 6.0	V
$\overline{SD}$	-0.3 to V <sub>CC</sub>	
RINN, RINP, LINN, LINP	0.3 to 6.0	
Junction Temperature Range T <sub>J</sub>	-40 to +150	°C
Storage Temperature	-65 to +150	
Lead Temperature 1, 6mm (1/16inch) from case for 5 seconds	260	

---

## Recommended Operating Conditions (@T<sub>A</sub> = +25°C, unless otherwise specified.)

---

Parameter	Rating	Unit
Supply Voltage (V <sub>CC</sub> )	7.5 to 18.0	V
Maximum Volume Control Pins, Input Pins Voltage	0 to 5.0	V
<b>High Level Input Voltage:</b>		
SD	2.0 to V <sub>CC</sub>	V
MUTE	2.0 to 5.0	
<b>Low Level Input Voltage:</b>		
SD	0 to 0.3	V
MUTE	0 to 0.3	
Ambient Operating Temperature	-20 to +85	°C
Junction Temperature Range, T <sub>J</sub>	-40 to +125	°C

---

## Thermal Information

---

Parameter	Package	Symbol	Max	Unit
Thermal Resistance (Junction to Ambient)	QFN 5x5	θ <sub>JA</sub>	18.1	°C/W
	TSSOP-28PP		27.8	
Thermal Resistance (Junction to Case)	QFN 5x5	θ <sub>JC</sub>	7.6	
	TSSOP-28PP		14.4	
Internal Power Dissipation (T <sub>A</sub> = +25°C)	QFN 5x5	P <sub>D</sub>	5.52	W
	TSSOP-28PP		3.60	

The exposed PAD must be soldered to a thermal land on the PCB

**Electrical Characteristics** (@ $T_A = +25^\circ\text{C}$ ,  $V_{CC} = 12\text{V}$ ,  $G_V = 24\text{dB}$ ,  $R_L = 8\Omega$ , unless otherwise specified.)

Symbol	Parameter	Test Conditions	Min	Typ	Max	Units	
$V_{CC}$	Supply Power		7.5	12	18	V	
$P_O$	Continuous Output Power	THD+N = 0.1%, $f = 1\text{kHz}$ , $R_L = 8\Omega$		5		W	
		THD+N = 1.0%, $f = 1\text{kHz}$ , $R_L = 8\Omega$		8		W	
		THD+N = 10%, $f = 1\text{kHz}$ , $R_L = 8\Omega$ , $V_{CC} = 13\text{V}$		10		W	
		THD+N = 10%, $f = 1\text{kHz}$ , $R_L = 4\Omega$ (Note 1)		15		W	
THD+N	Total Harmonic Distortion Plus Noise	$P_O = 5\text{W}$ , $f = 1\text{kHz}$ , $R_L = 8\Omega$		0.1		%	
$I_{CC}$	Quiescent Current	(No Load)		20	30	mA	
$I_{SD}$	Shutdown Quiescent Current in Shutdown Mode	SHUTDOWN = 0V		4	10	$\mu\text{A}$	
$R_{DS(ON)}$	Static Drain-to-Source On-State Resistor	$V_{CC} = 12\text{V}$ $I_O = 1\text{A}$ $T_A = +25^\circ\text{C}$	High Side		300		m $\Omega$
			Low Side		300		
			Total		600		
PSRR	Power Supply Ripple Rejection	1V <sub>PP</sub> Ripple, $f = 1\text{kHz}$ , Input AC-Coupled to Ground		-60		dB	
$f_{OSC}$	Oscillator Frequency	$C_{OSC} = 220\text{pF}$		250			
$V_N$	Output Integrated Noise Floor	20Hz to 22kHz, A-Weighting		-90		$\mu\text{V}$	
$C_S$	Crosstalk	$P_O = 3\text{W}$ , $R_L = 8\Omega$ , $f = 1\text{kHz}$		-80		dB	
SNR	Signal-to-Noise	Maximum Outout @ THD+N < 0.5%, $f = 1\text{kHz}$		95		dB	
$ V_{OS} $	Output Offset Voltage (Measured Differentially)	INN and INP Connected Together		30		mV	
V2P5	2.5V Bias Voltage	No Load		2.5			
AVDD	Internal Analog Supply Voltage	$V_{CC} = 7.5$ to 18		5	5.5		
OTS	Over Temperature Shutdown			150		$^\circ\text{C}$	
OTH	Temperature Hysteresis			40			

Note: 1. Heat sink is required for high power output.

**Typical Performance Characteristics** (@ $T_A = +25^\circ\text{C}$ ,  $R_L = 8\Omega$ ,  $V_{CC} = 12\text{V}$ ,  $G_v = 24\text{dB}$ , unless otherwise specified.)

1. THD+N vs. Power

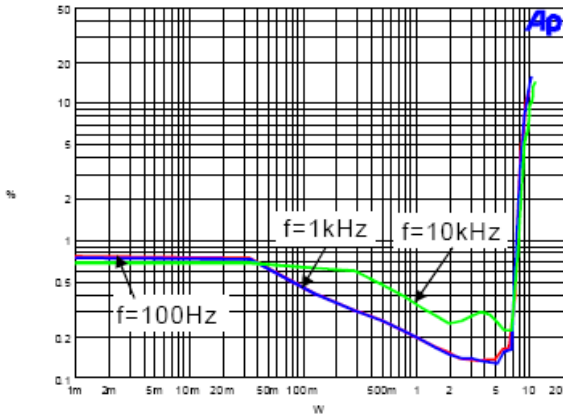

2. THD+N vs Frequency

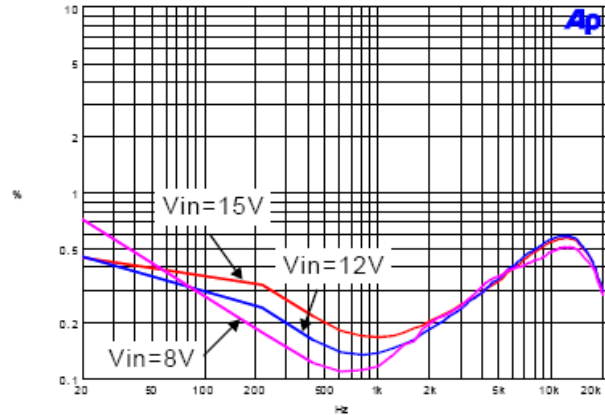

3. Power Supply Ripple Rejection

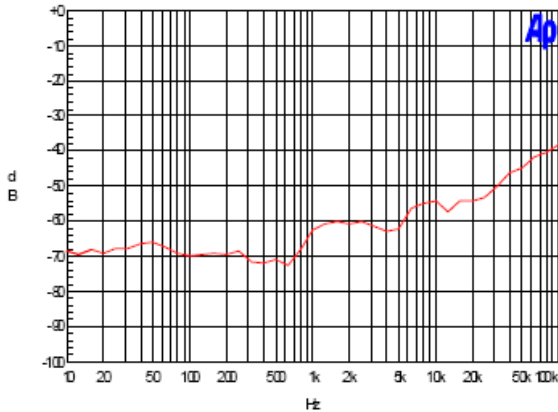

4. Noise Floor

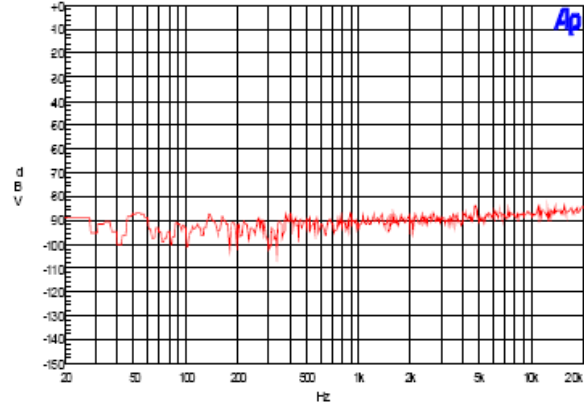

5. Crosstalk

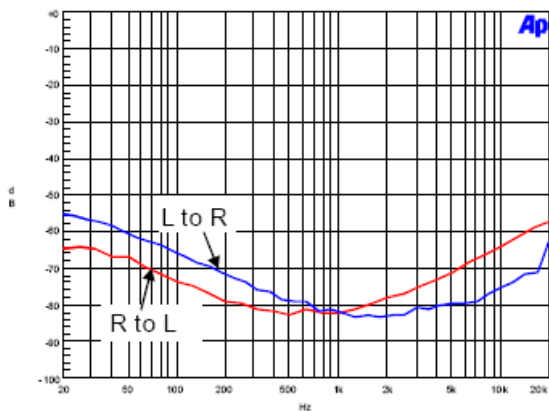

6. Frequency Response

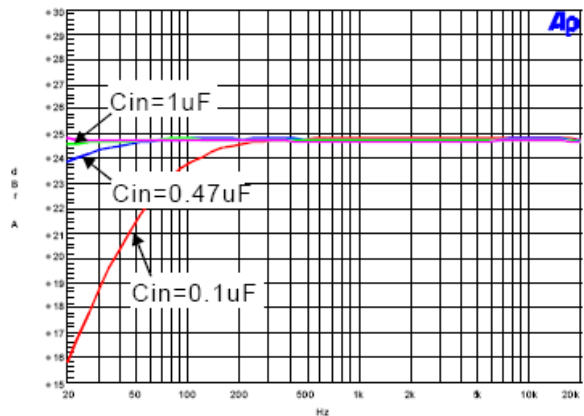

**Typical Performance Characteristics** (cont.) (@ $T_A = +25^\circ\text{C}$ ,  $R_L = 8\Omega$ ,  $V_{CC} = 12\text{V}$ ,  $G_V = 24\text{dB}$ , unless otherwise specified.)

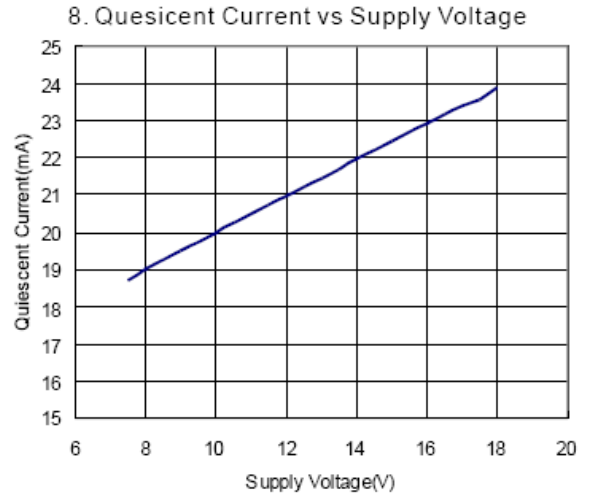
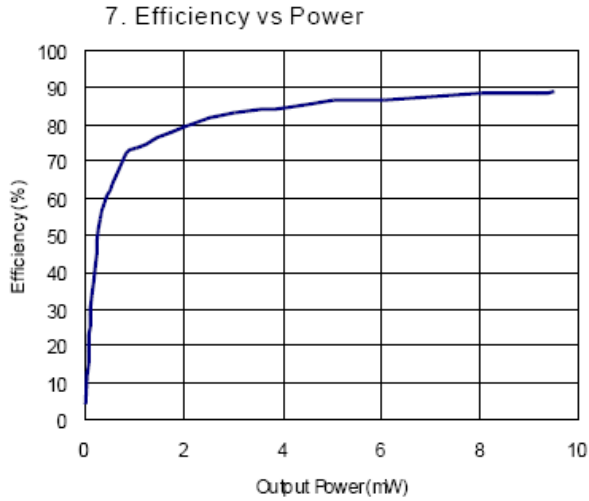



## Application Information

### Power and Heat Dissipation

Choose speakers that are able to stand large output power from the PAM8006. Otherwise, speaker may suffer damage.

Heat dissipation is very important when the device works in full power operation. Two factors affect the heat dissipation, the efficiency of the device that determines the dissipation power, and the thermal resistance of the package that determines the heat dissipation capability.

In operation, some of power is dissipated to the resistors.

$$\text{Power Dissipation: } P_{\text{LOSS}} = (P_o \cdot (1-\eta) / \eta) \cdot 2$$

The PAM8006's efficiency is 90% with 10W output and 8Ω load. The dissipation power is 2.22W.

Thermal resistance of junction to ambient of the QFN package is 18.1°C/W and the junction temperature  $T_J = P_{\text{LOSS}} \cdot \theta_{JA} + T_A$ , where  $T_A$  is ambient temperature. If the ambient temperature is +85°C, the QFN's junction temperature

$$T_J = 2.22 \cdot 18.1 + 85 = +125^\circ\text{C}$$

which is lower than +150°C rated junction temperature.

If the rated workable junction temperature is +150°C, the relationship between ambient temperature and permitted  $P_{\text{LOSS}}$  is shown in below diagram.

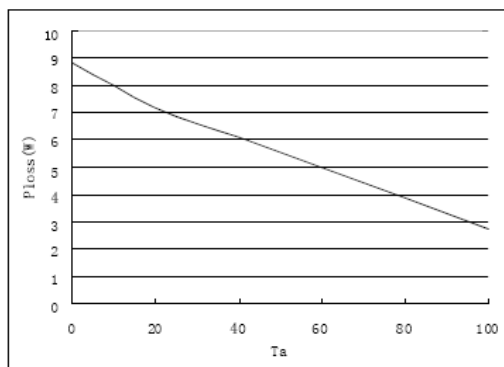

From the diagram, it can be found that when the device works at 10W/8Ω load the dissipation power is 1.1W per channel, 2.2W total, the permitted ambient temperature is over +100°C. This is proven by actual test. The PAM8006 can work in full output power under +85°C ambient temperature.

### Heat Dissipation in PCB Design

Generally, class-D amplifiers are high efficiency and need no heat sink. For high power ones that has high dissipation power, the heat sink may also not necessary if the PCB is carefully designed to achieve good heat dissipation by the PCB itself.

#### Dual-Side PCB

To achieve good heat dissipation, the PCB's copper plate should be thicker than 0.035mm and the copper plate on both sides of the PCB should be utilized for heat sink.

The thermal pad on the bottom of the device should be soldered to the plate of the PCB, and via holes, usually 9 to 16, should be drilled in the PCB area under the device and deposited copper on the vias should be thick enough so that the heat can be dissipated to the other side of the plate. There should be no insulation mask on the other side of the copper plate. It is better to drill more vias on the PCB around the device if possible.

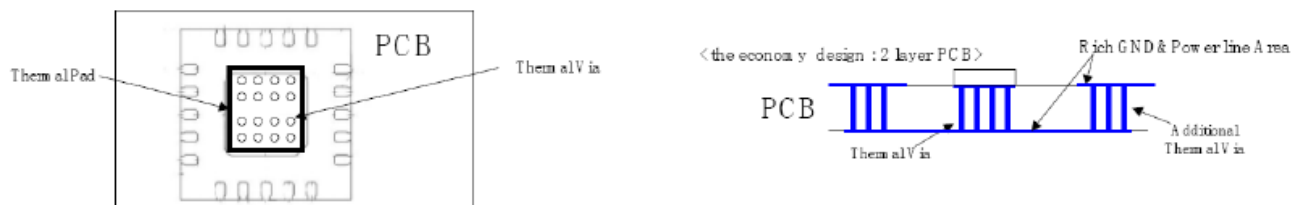

## Application Information (cont.)

### 4-Layer PCB

If it is 4-layer PCB, the two middle layers of grounding and power can be employed for heat dissipation, isolating them into several islands to avoid short between ground and power.

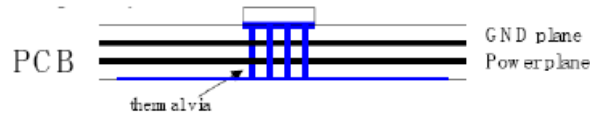

### Consideration for EMI

Filters are not required if the traces from the amplifier to the speakers are short (< 20cm). But most applications require a ferrite bead filter as shown in below figure. The ferrite bead filter reduces EMI of around 1MHz and higher to meet the FCC and CE's requirements. It is recommended to use a ferrite bead with very low impedances at low frequencies and high impedance at high frequencies (above 1MHz).

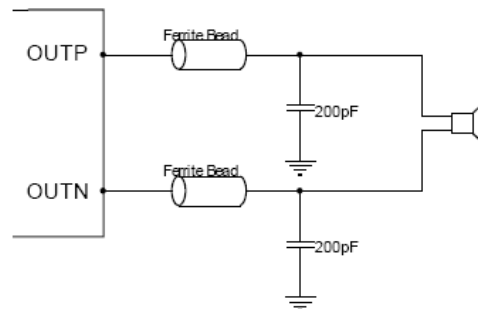

The EMI characteristics are as follows after employing the ferrite bead.

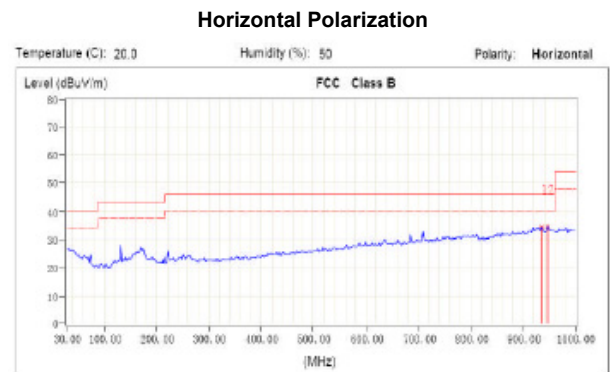
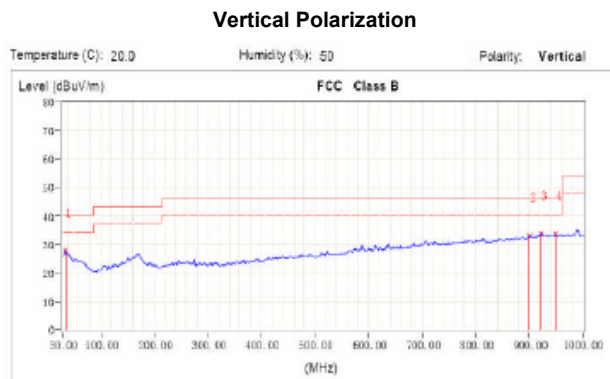

### MUTE Operation

The MUTE pin is an input for controlling the output state of the PAM8006. A logic high on this pin disables the outputs and low enables the outputs. This pin may be used as a quick disable or enable of the outputs.

For power saving, the  $\overline{SD}$  pin should be used to reduce the quiescent current to the absolute minimum level.

### Shutdown Operation

The PAM8006 employs a shutdown operation mode to reduce supply current to the absolute minimum level during periods of non-use to save power. The  $\overline{SD}$  input terminal should be held high during normal operation when the amplifier is in use. Pulling  $\overline{SD}$  low causes the outputs to mute and the amplifier to enter a low-current state.  $\overline{SD}$  should never be left unconnected to prevent the amplifier from unpredictable operation.

For the best power-off pop performance, the amplifier should be set in shutdown mode prior to removing the power supply voltage.

---

## Application Information (cont.)

---

### Internal 2.5V Bias Generator Capacitor Selection

The internal 2.5V bias generator (V2P5) provides the internal bias for the preamplifier stage. The external input capacitors and this internal reference allow the inputs to be biased within the optimal common-mode range of the input preamplifiers.

The selection of the capacitor value on the V2P5 terminal is critical for achieving the best device performance. During startup or recovery from shutdown state, the V2P5 capacitor determines the rate at which the amplifier starts up. When the voltage on the V2P5 capacitor equals  $0.75 \times V_{2P5}$ , or 75% of its final value, the device turns on and the Class-D outputs start switching. The startup time is not critical for the best de-pop performance since any heard pop sound is the result of the Class-D output switching-on other than that of the startup time. However, at least a  $0.47\mu\text{F}$  capacitor is recommended for the V2P5 capacitor.

Another function of the V2P5 capacitor is to filter high frequency noise on the internal 2.5V bias generator.

### Power Supply Decoupling, $C_s$

The PAM8006 is a high-performance CMOS audio amplifier that requires adequate power supply decoupling to ensure the output total harmonic distortion (THD) as low as possible. Power supply decoupling also prevents oscillations caused by long lead between the amplifier and the speaker. The optimum decoupling is achieved by using two capacitors of different types that target different types of noise on the power supply leads. For higher frequency transients, spikes, or digital hash on the line, a good low equivalent-series-resistance (ESR) ceramic capacitor, typically  $1\mu\text{F}$ , is recommended, placing as close as possible to the device's VCC lead. To filter lower-frequency noises, a large aluminum electrolytic capacitor of  $10\mu\text{F}$  or greater is recommended, placing near the audio power amplifier. The  $10\mu\text{F}$  capacitor also serves as a local storage capacitor for supplying current during large signal transients on the amplifier outputs.

### BSN and BSP Capacitors

The full H-bridge output stages use NMOS transistors only. They therefore require bootstrap capacitors for the high side of each output to turn on correctly. A at least  $220\text{nF}$  ceramic capacitor, rated for at least 25V, must be connected from each output to its corresponding bootstrap input. Specifically, one  $220\text{nF}$  capacitor must be connected from xOUTP to xBSP, and another  $220\text{nF}$  capacitor from xOUTN to xBSN. It is recommended to use  $1\mu\text{F}$  BST capacitor to replace  $220\text{nF}$  (pin15, pin16, pin35 and pin36) for lower than 100Hz applications.

### VCLAMP Capacitors

To ensure that the maximum gate-to-source voltage for the NMOS output transistors not exceeded, two internal regulators are used to clamp the gate voltage. Two  $1\mu\text{F}$  capacitors must be connected from VCLAMP to ground and must be rated for at least 25V. The voltages at the VCLAMP terminals vary with  $V_{CC}$  and may not be used to power any other circuitry.

### Internal Regulated 5-V Supply (AVDD)

The AVDD terminal is the output of an internally generated 5V supply, used for the oscillator, preamplifier. It requires a  $0.1\mu\text{F}$  to  $1\mu\text{F}$  capacitor, placed very close to the pin to Ground to keep the regulator stable. The regulator may not be used to power any external circuitry.

### Differential Input

The differential input stage of the amplifier eliminates noises that appear on the two input lines of the channel. To use the PAM8006 with a differential source, connect the positive lead of the audio source to the INP input and the negative lead from the audio source to the INN input. To use the PAM8006 with a single-ended source, acground the INP input through a capacitor equal in value to the input capacitor on INN and apply the audio source to the INN input. In a single-ended input application, the INP input should be acgrounded at the audio source other than at the device input for best noise performance.

### Using Low-ESR Capacitors

Low-ESR capacitors are recommended throughout this application section. A real (with respect to ideal) capacitor can be modeled simply as a resistor in series with an ideal capacitor. The voltage drop across this resistor minimizes the beneficial effects of the capacitor in the circuit. The lower the equivalent value of this resistance the more the real capacitor behaves as an ideal capacitor.

### Short-Circuit Protection

The PAM8006 has short circuit protection circuitry on the outputs to prevent damage to the device when output-to-output shorts, output-to-GND shorts, or output-to-VCC shorts occur. Once a short-circuit is detected on the outputs, the output drive is immediately disabled. This is a latched fault and must be reset by cycling the voltage on the  $\overline{SD}$  pin to a logic low and back to the logic high state for normal operation. This will clear the short-circuit flag and allow for normal operation if the short was removed. If the short was not removed, the protection circuitry will again activate.

## Application Information (cont.)

### Selection of $C_{OSC}$ and Frequency Setting

The switching frequency is determined by the values of components connected to  $C_{OSC}$  and calculated as follows:

$$f_{OSC} = 22 / (C_{OSC} * R)$$

R is the internal resistor and the value is 400k $\Omega$  and with  $\pm 20\%$  tolerance. The frequency may vary from 200kHz to 300kHz by adjusting the values of  $C_{OSC}$ . The recommended value is  $C_{OSC} = 220\text{pF}$  for a switching frequency of 250kHz.

### Selection of Gain and Input Signal Amplitude

The PAM8006 has two internal amplifier stages with fixed gain. The pre-amp stage gain is 10X, while the second stage gain is 5X.

The pre-amp is powered internally by the 5V value of AVDD. At maximum pre-amp gain operation for avoiding the pre-amp saturation, it's worth noting that the peak value of input signal ( $V_P$ ) shouldn't exceed 250mV when the THD+N of PAM8006 is lower than 1%; and the  $V_P$  value shouldn't exceed 300mV when the THD+N is lower than 10%.

Total gain is calculated as follows:

$$\text{Gain} = 20\log[100k / (10k + R_{IN}) * 5]$$

( $R_{IN}$  is external input resistor.)

### Thermal Protection

Thermal protection on the PAM8006 prevents damage to the device when the internal die temperature exceeds +150°C. There is a  $\pm 15$  degree tolerance on this trip point from device to device. Once the die temperature exceeds the set thermal point, the device enters into the shutdown state and the outputs are disabled. This is not a latched fault. The thermal fault is cleared once the temperature of the die is reduced by +40°C. The device begins normal operation at this point without external system intervention.

### Test Setup for Performance Testing

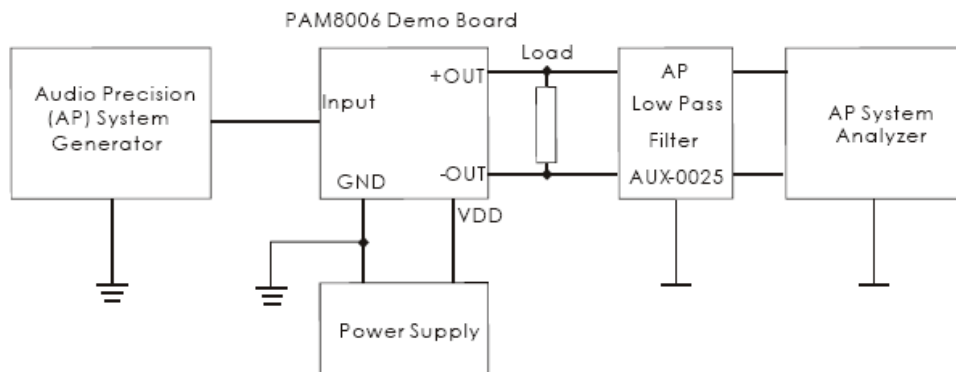

- Notes:
2. The Audio Precision (AP) AUX-0025 low pass filter is necessary for Class-D amplifier measurement with AP analyzer.
  3. Two 22 $\mu\text{H}$  inductors are used in series with load resistor to emulate the small speaker for efficiency measurement.

**Ordering Information**

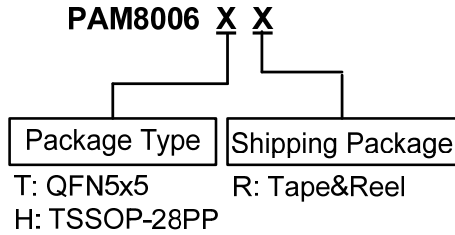

Part Number	Part Marking	Package Type	Standard Package
PAM8006TR	PAM8006 XATYWWLL	QFN5x5	3000 Units/Tape&Reel
PAM8006HR	PAM8006 XATYWWLL	TSSOP-28PP	2500 Units/Tape&Reel

**Marking Information**

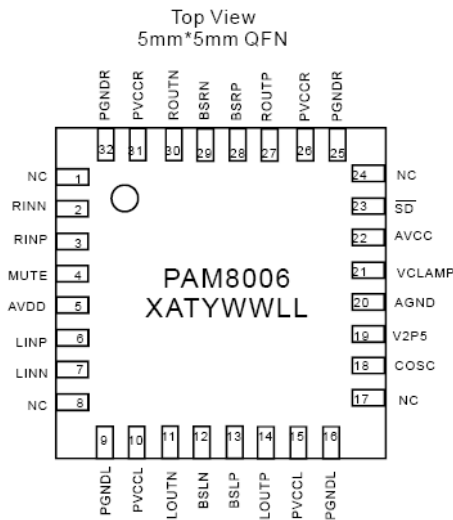

- X: Internal Code
- A: Assembly Code
- T: Testing Code
- Y: Year
- WW: Week
- LL: Internal Code

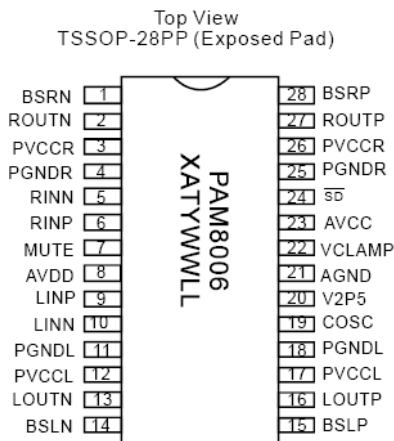

**Package Outline Dimensions** (All dimensions in mm.)

QFN5x5-32

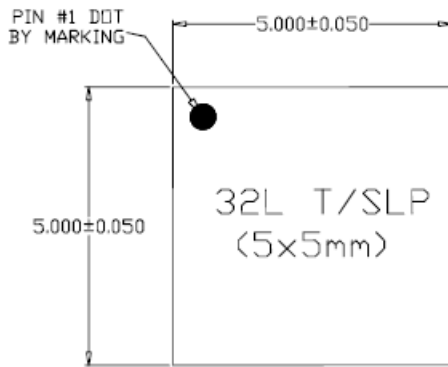

TOP VIEW

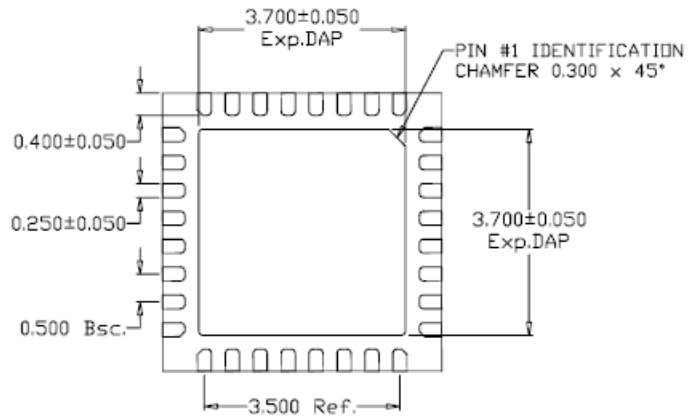

BOTTOM VIEW

A	MAX.	0.800
	NOM.	0.750
	MIN.	0.700

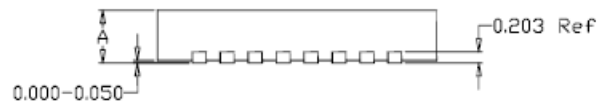

SIDE VIEW

**Package Outline Dimensions** (cont.) (All dimensions in mm.)

**TSSOP-28PP**

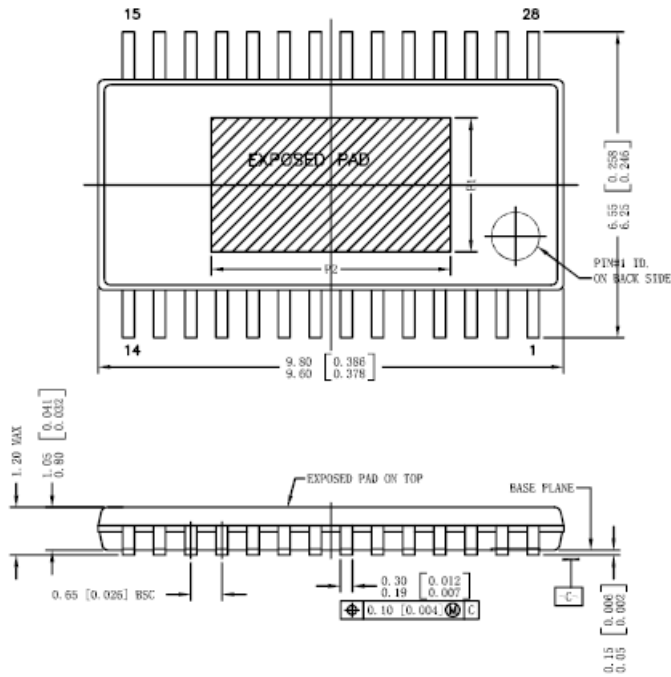

**NOTES:**

- 1) LEADFRAME MATERIAL : C7025 (THICKNESS: 0.127MM).
- 2) BOTH PACKAGE LENGTH & WIDTH DO NOT INCLUD MOLD FLASH.
- 3) FORMED LEAD SHALL BE PLANAR WITH RESPECT TO ONE ANOTHER WITHIN 0.10MM.
- 4) UNREMOVED FLASH BETWEEN LEADS & PACKAGE END FLASH SHALL NOT EXCEED 0.15MM FROM BOTTOM BODY PER SIDE.
- 5) EXPOSED PAD SIZE P1 & P2 ARE VARIATIONS DEPENDING ON DEVICE FUNCTION (DIE PADDLE SIZE).
- 6) EXPOSED PAD ON TOP.
- 7) CONTROLLING DIMENSION : MM [INCH].

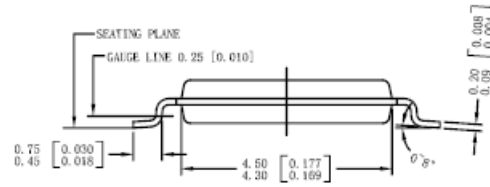

PAD SIZE	EXPOSED PAD SIZE	
	P1	P2
3.0 X 5.1 [.118 X .200]	MAX	3.05 [0.120] 5.15 [0.202]
	MIN	2.74 [0.108] 4.84 [0.190]

**IMPORTANT NOTICE**

DIODES INCORPORATED MAKES NO WARRANTY OF ANY KIND, EXPRESS OR IMPLIED, WITH REGARDS TO THIS DOCUMENT, INCLUDING, BUT NOT LIMITED TO, THE IMPLIED WARRANTIES OF MERCHANTABILITY AND FITNESS FOR A PARTICULAR PURPOSE (AND THEIR EQUIVALENTS UNDER THE LAWS OF ANY JURISDICTION).

Diodes Incorporated and its subsidiaries reserve the right to make modifications, enhancements, improvements, corrections or other changes without further notice to this document and any product described herein. Diodes Incorporated does not assume any liability arising out of the application or use of this document or any product described herein; neither does Diodes Incorporated convey any license under its patent or trademark rights, nor the rights of others. Any Customer or user of this document or products described herein in such applications shall assume all risks of such use and will agree to hold Diodes Incorporated and all the companies whose products are represented on Diodes Incorporated website, harmless against all damages.

Diodes Incorporated does not warrant or accept any liability whatsoever in respect of any products purchased through unauthorized sales channel.

Should Customers purchase or use Diodes Incorporated products for any unintended or unauthorized application, Customers shall indemnify and hold Diodes Incorporated and its representatives harmless against all claims, damages, expenses, and attorney fees arising out of, directly or indirectly, any claim of personal injury or death associated with such unintended or unauthorized application.

Products described herein may be covered by one or more United States, international or foreign patents pending. Product names and markings noted herein may also be covered by one or more United States, international or foreign trademarks.

This document is written in English but may be translated into multiple languages for reference. Only the English version of this document is the final and determinative format released by Diodes Incorporated.

**LIFE SUPPORT**

Diodes Incorporated products are specifically not authorized for use as critical components in life support devices or systems without the express written approval of the Chief Executive Officer of Diodes Incorporated. As used herein:

A. Life support devices or systems are devices or systems which:

1. are intended to implant into the body, or
2. support or sustain life and whose failure to perform when properly used in accordance with instructions for use provided in the labeling can be reasonably expected to result in significant injury to the user.

B. A critical component is any component in a life support device or system whose failure to perform can be reasonably expected to cause the failure of the life support device or to affect its safety or effectiveness.

Customers represent that they have all necessary expertise in the safety and regulatory ramifications of their life support devices or systems, and acknowledge and agree that they are solely responsible for all legal, regulatory and safety-related requirements concerning their products and any use of Diodes Incorporated products in such safety-critical, life support devices or systems, notwithstanding any devices- or systems-related information or support that may be provided by Diodes Incorporated. Further, Customers must fully indemnify Diodes Incorporated and its representatives against any damages arising out of the use of Diodes Incorporated products in such safety-critical, life support devices or systems.

Copyright © 2012, Diodes Incorporated

[www.diodes.com](http://www.diodes.com)