



# Fast, Low-Voltage, Dual 4Ω SPDT CMOS Analog Switches

MAX4635/MAX4636

## General Description

The MAX4635/MAX4636 are fast, dual 4Ω single-pole/double-throw (SPDT) analog switches that operate with supply voltages from +1.8V to +5.5V. High switching speeds, 1Ω on-resistance flatness, and low power consumption make these devices ideal for audio/video, communications, and battery-operated devices. Containing two independently controllable SPDT switches in 10-pin μMAX and 10-pin 3mm x 3mm thin QFN packages, the MAX4635/MAX4636 use little board space, and have low power consumption ensuring minimal impact on your power budget. The analog signal range extends to the supply rails. The MAX4635 has inverted logic compared to the MAX4636.

## Applications

- Battery-Powered Equipment
- Relay Replacement
- Audio and Video Signal Routing
- Low-Voltage Data-Acquisition Systems
- Sample-and-Hold Circuits
- Communications Circuits

## Features

- ◆ **Guaranteed On-Resistance**  
4Ω (max) +5V Supply  
5.5Ω (max) +3V Supply
- ◆ **Guaranteed Match Between Channels**  
0.2Ω (max)
- ◆ **Guaranteed Flatness Over Signal Range**  
1Ω (max) with +5V Supply
- ◆ **Fast Switching Speeds**  
14ns (max) Turn-On Time  
6ns (max) Turn-Off Time
- ◆ **1.8V Operation**  
100Ω (typ) On-Resistance Over Temperature  
56ns (typ) Turn-On Time  
17ns (typ) Turn-Off Time
- ◆ **+1.8V to +5.5V Single-Supply Operation**
- ◆ **Rail-to-Rail® Signal Handling**
- ◆ **Low Crosstalk: -67dB at 1MHz**
- ◆ **High Off-Isolation: -65dB at 1MHz**
- ◆ **THD: 0.1%**

## Ordering Information

PART	TEMP RANGE	PIN-PACKAGE	TOP MARK
MAX4635EUB	-40°C to +85°C	10 μMAX	—
MAX4635ETB	-40°C to +85°C	10 Thin QFN (3 × 3)	AAT
MAX4636EUB	-40°C to +85°C	10 μMAX	—
MAX4636ETB	-40°C to +85°C	10 Thin QFN (3 × 3)	AAO

Rail-to-Rail is a registered trademark of Nippon Motorola, Ltd.

## Pin Configuration/Functional Diagram/Truth Table

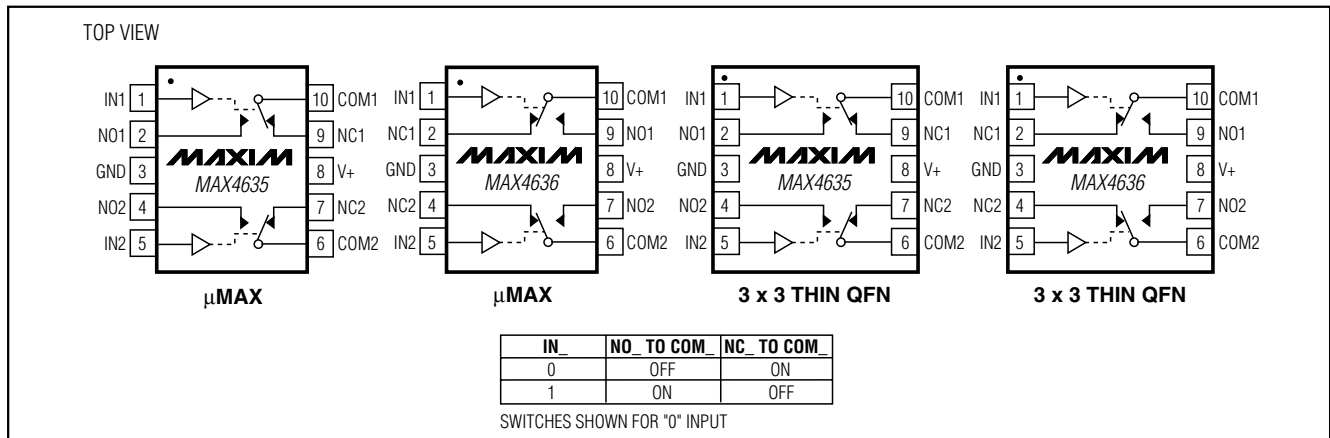

# Fast, Low-Voltage, Dual 4Ω SPDT CMOS Analog Switches

## ABSOLUTE MAXIMUM RATINGS

(Voltages Referenced to GND)

V+, IN_	-0.3V to +6V
COM_, NC_, NO_ (Note 1)	-0.3V to (V+ + 0.3V)
Continuous Current into Any Terminal	±30mA
Peak Current into COM_, NC_, NO_ (pulsed at 1ms, 10% duty cycle)	±100mA

Continuous Power Dissipation (T<sub>A</sub> = +70°C)

10-Pin μMAX (derate 4.7mW/°C above +70°C)	330mW
10-Pin Thin QFN (derate 24.4mW/°C above +70°C)	1951mW
Operating Temperature Range	-40°C to +85°C
Storage Temperature Range	-65°C to +150°C
Lead Temperature (soldering, 10s)	+300°C

**Note 1:** Signals on NO\_, NC\_, or COM\_ exceeding V+ or GND are clamped by internal diodes. Limit forward-diode current to maximum current rating.

Stresses beyond those listed under "Absolute Maximum Ratings" may cause permanent damage to the device. These are stress ratings only, and functional operation of the device at these or any other conditions beyond those indicated in the operational sections of the specifications is not implied. Exposure to absolute maximum rating conditions for extended periods may affect device reliability.

## ELECTRICAL CHARACTERISTICS—Single +5V Supply

(V+ = +4.5V to +5.5V, V<sub>IH</sub> = +2.4V, V<sub>IL</sub> = +0.8V, T<sub>A</sub> = T<sub>MIN</sub> to T<sub>MAX</sub>, unless otherwise noted. Typical values are at T<sub>A</sub> = +25°C.) (Notes 2, 9)

PARAMETER	SYMBOL	CONDITIONS	MIN	TYP	MAX	UNITS	
<b>ANALOG SWITCH</b>							
Analog Signal Range	V <sub>COM_</sub> , V <sub>NO_</sub> , V <sub>NC_</sub>		0		V+	V	
On-Resistance	R <sub>ON</sub>	V+ = 4.5V, I <sub>COM_</sub> = 10mA, V <sub>NO_</sub> or V <sub>NC_</sub> = 0 to V+	T <sub>A</sub> = +25°C	2.5	4	Ω	
			T <sub>A</sub> = T <sub>MIN</sub> to T <sub>MAX</sub>		4.5		
On-Resistance Match Between Channels (Notes 3, 4)	ΔR <sub>ON</sub>	V+ = 4.5V, I <sub>COM_</sub> = 10mA, V <sub>NO_</sub> or V <sub>NC_</sub> = 0 to V+	T <sub>A</sub> = +25°C	0.1	0.2	Ω	
			T <sub>A</sub> = T <sub>MIN</sub> to T <sub>MAX</sub>		0.4		
On-Resistance Flatness (Note 5)	R <sub>FLAT(ON)</sub>	V+ = 4.5V, I <sub>COM_</sub> = 10mA, V <sub>NO_</sub> or V <sub>NC_</sub> = 0 to V+	T <sub>A</sub> = +25°C	0.5	1	Ω	
			T <sub>A</sub> = T <sub>MIN</sub> to T <sub>MAX</sub>		1.2		
NO_, NC_ Off-Leakage Current (Note 6)	I <sub>NC_(OFF)</sub> , I <sub>NO_(OFF)</sub>	V+ = 5.5V; V <sub>COM_</sub> = 1V, 4.5V; V <sub>NO_</sub> or V <sub>NC_</sub> = 4.5V, 1V	T <sub>A</sub> = +25°C	-0.1	±0.01	0.1	nA
			T <sub>A</sub> = T <sub>MIN</sub> to T <sub>MAX</sub>	-0.3		0.3	
COM_ Off-Leakage Current (Note 6)	I <sub>COM_(OFF)</sub>	V+ = 5.5V; V <sub>COM_</sub> = 1V, 4.5V; V <sub>NO_</sub> or V <sub>NC_</sub> = 4.5V, 1V	T <sub>A</sub> = +25°C	-0.1	±0.01	0.1	nA
			T <sub>A</sub> = T <sub>MIN</sub> to T <sub>MAX</sub>	-0.3		0.3	
COM_ On-Leakage Current (Note 6)	I <sub>COM_(ON)</sub>	V+ = 5.5V; V <sub>COM_</sub> = 4.5V, 1V; V <sub>NO_</sub> or V <sub>NC_</sub> = 4.5V, 1V or floating	T <sub>A</sub> = +25°C	-0.1	±0.01	0.1	nA
			T <sub>A</sub> = T <sub>MIN</sub> to T <sub>MAX</sub>	-0.3		0.3	
<b>DIGITAL I/O (IN1, IN2)</b>							
Input Logic High	V <sub>IH</sub>		2.4			V	
Input Logic Low	V <sub>IL</sub>				0.8	V	
Input Leakage Current	I <sub>IH</sub> , I <sub>IL</sub>	V <sub>IN_</sub> = 0 or +5.5V	-100	5	100	nA	

# Fast, Low-Voltage, Dual 4Ω SPDT CMOS Analog Switches

MAX4635/MAX4636

## ELECTRICAL CHARACTERISTICS—Single +5V Supply (continued)

(V+ = +4.5V to +5.5V, VIH = +2.4V, VIL = +0.8V, TA = TMIN to TMAX, unless otherwise noted. Typical values are at TA = +25°C.) (Notes 2, 9)

PARAMETER	SYMBOL	CONDITIONS	MIN	TYP	MAX	UNITS
<b>DYNAMIC</b>						
Turn-On Time (Note 6)	tON	VNO_, VNC_ = 3V; RL = 300Ω, CL = 35pF, Figure 1a	TA = +25°C	12	14	ns
			TA = TMIN to TMAX		16	
Turn-Off Time (Note 6)	tOFF	VNO_, VNC_ = 3V; RL = 300Ω, CL = 35pF, Figure 1a	TA = +25°C	5	6	ns
			TA = TMIN to TMAX		8	
Break-Before-Make Time (Note 6)	tBBM	VNO_, VNC_ = 3V; RL = 300Ω, CL = 35pF, Figure 1b	TA = +25°C	7		ns
			TA = TMIN to TMAX	1		
Charge Injection	Q	VGEN = 2V, RGEN = 0, CL = 1.0nF, Figure 2		2		pC
NO_, NC_ Off-Capacitance	CNO_(OFF), CNC_(OFF)	VNO_, VNC_ = GND, f = 1MHz, Figure 3		9		pF
COM_ On-Capacitance	CCOM_(ON)	VCOM_ = GND, f = 1MHz, Figure 3		32		pF
Off-Isolation (Note 7)	VISO	CL = 5pF, RL = 50Ω, f = 10MHz, Figure 4		-52		dB
		CL = 5pF, RL = 50Ω, f = 1MHz, Figure 4		-65		
Crosstalk (Note 8)	VCT	CL = 5pF, RL = 50Ω, f = 10MHz, Figure 4		-66		dB
		CL = 5pF, RL = 50Ω, f = 1MHz, Figure 4		-67		
Total Harmonic Distortion	THD	RL = 600Ω, VNO_ = 5Vp-p, f = 20Hz to 20kHz		0.1		%
<b>SUPPLY</b>						
Positive Supply Current	I+	V+ = 5.5V, VIN_ = 0 or V+		0.001	1.0	μA

## ELECTRICAL CHARACTERISTICS—Single +3V Supply

(V+ = +2.7V to +3.6V, VIH = +2.0V, VIL = +0.8V, TA = TMIN to TMAX, unless otherwise noted. Typical values are at TA = +25°C.) (Notes 2, 9)

PARAMETER	SYMBOL	CONDITIONS	MIN	TYP	MAX	UNITS	
<b>ANALOG SWITCH</b>							
Analog Signal Range	VCOM_, VNO_, VNC_		0		V+	V	
On-Resistance	RON	V+ = 2.7V, ICOM_ = 10mA, VNO_ or VNC_ = 0 to V+	TA = +25°C	5	5.5	Ω	
			TA = TMIN to TMAX		8		
On-Resistance Match Between Channels (Notes 3, 4)	ΔRON	V+ = 2.7V, ICOM_ = 10mA, VNO_ or VNC_ = 0 to V+	TA = +25°C	0.1	0.2	Ω	
			TA = TMIN to TMAX		0.4		
On-Resistance Flatness (Note 5)	RFLAT(ON)	V+ = 2.7V, ICOM_ = 10mA, VNO_ or VNC_ = 0 to V+	TA = +25°C	1.5	2	Ω	
			TA = TMIN to TMAX		2.5		
NO_, NC_ Off-Leakage Current (Note 6)	INO_(OFF), INC_(OFF)	V+ = 3.3V; VCOM_ = 1V, 3V; VNO_ or VNC_ = 3V, 1V	TA = +25°C	-0.1	±0.01	0.1	nA
			TA = TMIN to TMAX	-0.3		0.3	
COM_ Off-Leakage Current (Note 6)	ICOM_(OFF)	V+ = 3.3V; VCOM_ = 1V, 3V; VNO_ or VNC_ = 3V, 1V	TA = +25°C	-0.1	±0.01	0.1	nA
			TA = TMIN to TMAX	-0.3		0.3	

# Fast, Low-Voltage, Dual 4Ω SPDT CMOS Analog Switches

## ELECTRICAL CHARACTERISTICS—Single +3V Supply (continued)

(V+ = +2.7V to +3.6V, V<sub>IH</sub> = +2.0V, V<sub>IL</sub> = +0.8V, T<sub>A</sub> = T<sub>MIN</sub> to T<sub>MAX</sub>, unless otherwise noted. Typical values are at T<sub>A</sub> = +25°C.) (Notes 2, 9)

PARAMETER	SYMBOL	CONDITIONS	MIN	TYP	MAX	UNITS	
COM_ On-Leakage Current (Note 6)	I <sub>COM(ON)</sub>	V+ = 3.3V; V <sub>COM_</sub> = 1V, 3V; V <sub>NO_</sub> or V <sub>N_</sub> = 1V, 3V, or floating	T <sub>A</sub> = +25°C	-0.1	±0.01	0.1	nA
			T <sub>A</sub> = T <sub>MIN</sub> to T <sub>MAX</sub>	-0.3		0.3	
<b>DIGITAL I/O (IN1, IN2)</b>							
Input Logic High	V <sub>IH</sub>		2.0			V	
Input Logic Low	V <sub>IL</sub>				0.4	V	
Input Leakage Current	I <sub>IH</sub> , I <sub>IL</sub>	V <sub>IN_</sub> = 0 or +5.5V	-100	5	100	nA	
<b>DYNAMIC</b>							
Turn-On Time (Note 6)	t <sub>ON</sub>	V <sub>NO_</sub> , V <sub>N_</sub> = 2V; C <sub>L</sub> = 35pF, R <sub>L</sub> = 300Ω, Figure 1a	T <sub>A</sub> = +25°C	14	18	ns	
			T <sub>A</sub> = T <sub>MIN</sub> to T <sub>MAX</sub>		20		
Turn-Off Time (Note 6)	t <sub>OFF</sub>	V <sub>NO_</sub> , V <sub>N_</sub> = 2V; C <sub>L</sub> = 35pF, R <sub>L</sub> = 300Ω, Figure 1a	T <sub>A</sub> = +25°C	6	8	ns	
			T <sub>A</sub> = T <sub>MIN</sub> to T <sub>MAX</sub>		10		
Break-Before-Make Time (Note 6)		V <sub>NO_</sub> , V <sub>N_</sub> = 2V; C <sub>L</sub> = 35pF, R <sub>L</sub> = 300Ω, Figure 1b	T <sub>A</sub> = +25°C	7		ns	
			T <sub>A</sub> = T <sub>MIN</sub> to T <sub>MAX</sub>	1			
Charge Injection	Q	V <sub>GEN</sub> = 1.5V, R <sub>GEN</sub> = 0, C <sub>L</sub> = 1.0nF, Figure 2		11		pC	
NO_, NC_ Off-Capacitance	C <sub>NO_(OFF)</sub> , C <sub>N_(OFF)</sub>	V <sub>NO_</sub> , V <sub>N_</sub> = GND, f = 1MHz, Figure 3		9		pF	
COM On-Capacitance	C <sub>COM(ON)</sub>	V <sub>COM</sub> = GND, f = 1MHz, Figure 3		32		pF	
Off-Isolation (Note 7)	V <sub>ISO</sub>	C <sub>L</sub> = 5pF, R <sub>L</sub> = 50Ω, f = 10MHz, Figure 4		-52		dB	
		C <sub>L</sub> = 5pF, R <sub>L</sub> = 50Ω, f = 1MHz, Figure 4		-65			
Crosstalk (Note 8)	V <sub>CT</sub>	C <sub>L</sub> = 5pF, R <sub>L</sub> = 50Ω, f = 10MHz, Figure 4		-66		dB	
		C <sub>L</sub> = 5pF, R <sub>L</sub> = 50Ω, f = 1MHz, Figure 4		-67			
<b>SUPPLY</b>							
Positive Supply Current	I+	V+ = 3.6V, V <sub>IN</sub> = 0 or +3.6V		0.001	1	μA	

**Note 2:** The algebraic convention, where the most negative value is a minimum and the most positive value a maximum, is used in this data sheet.

**Note 3:**  $\Delta R_{ON} = R_{ON(MAX)} - R_{ON(MIN)}$ .

**Note 4:**  $\Delta R_{ON}$  matching specifications for QFN-packaged parts are guaranteed by design.

**Note 5:** Flatness is defined as the difference between the maximum and minimum values of on-resistance as measured over the specified analog signal ranges.

**Note 6:** Guaranteed by design.

**Note 7:** Off-Isolation =  $20 \log_{10} (V_{COM} / V_{NO})$ , V<sub>COM</sub> = output, V<sub>NO</sub> = input to off switch.

**Note 8:** Between any two switches.

**Note 9:** QFN packaged parts are tested at +25°C and guaranteed by design and correlation over the entire temperature range.

# Fast, Low-Voltage, Dual 4Ω SPDT CMOS Analog Switches

## Typical Operating Characteristics

( $T_A = +25^\circ\text{C}$ , unless otherwise noted.)

MAX4635/MAX4636

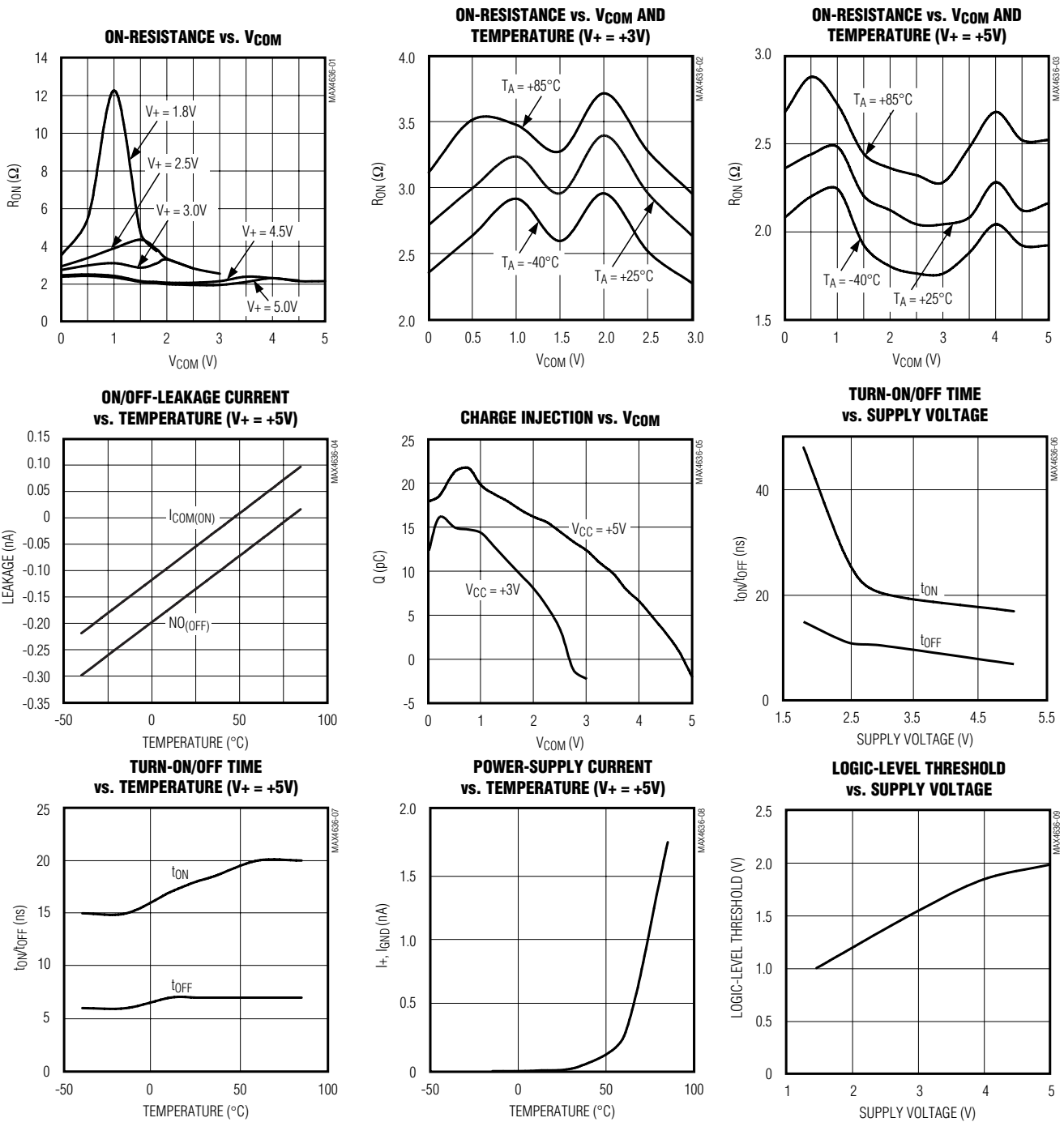

# Fast, Low-Voltage, Dual 4Ω SPDT CMOS Analog Switches

## Typical Operating Characteristics (continued)

(T<sub>A</sub> = +25°C, unless otherwise noted.)

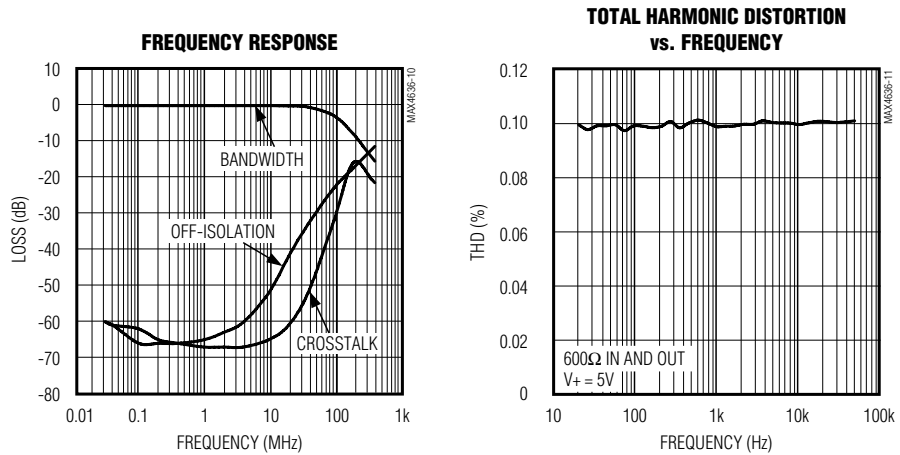

## Pin Description

PIN		NAME	FUNCTION
MAX4635	MAX4636		
1	1	IN1	Logic Control for Switch 1
2	9	NO1	Normally Open Terminal of Switch 1
3	3	GND	Ground
4	7	NO2	Normally Open Terminal of Switch 2
5	5	IN2	Logic Control Input for Switch 2
6	6	COM2	Common Terminal of Switch 2
7	4	NC2	Normally Closed Terminal of Switch 2
8	8	V+	Input Supply Voltage, +1.8V to +5.5V
9	2	NC1	Normally Closed Terminal of Switch 1
10	10	COM1	Common Terminal of Switch 1

# Fast, Low-Voltage, Dual 4Ω SPDT CMOS Analog Switches

MAX4635/MAX4636

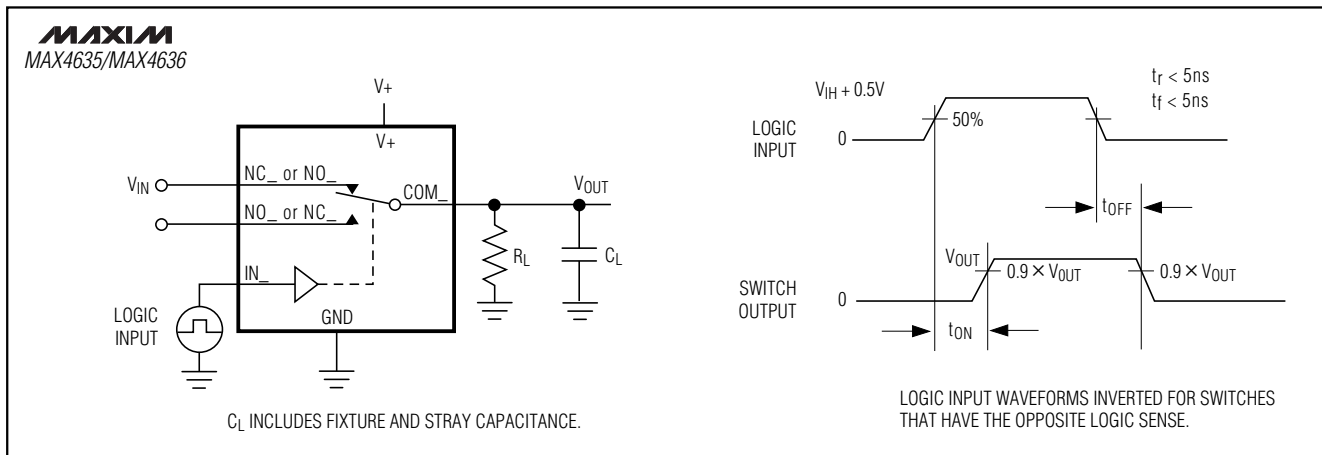

Figure 1a. Switching Time

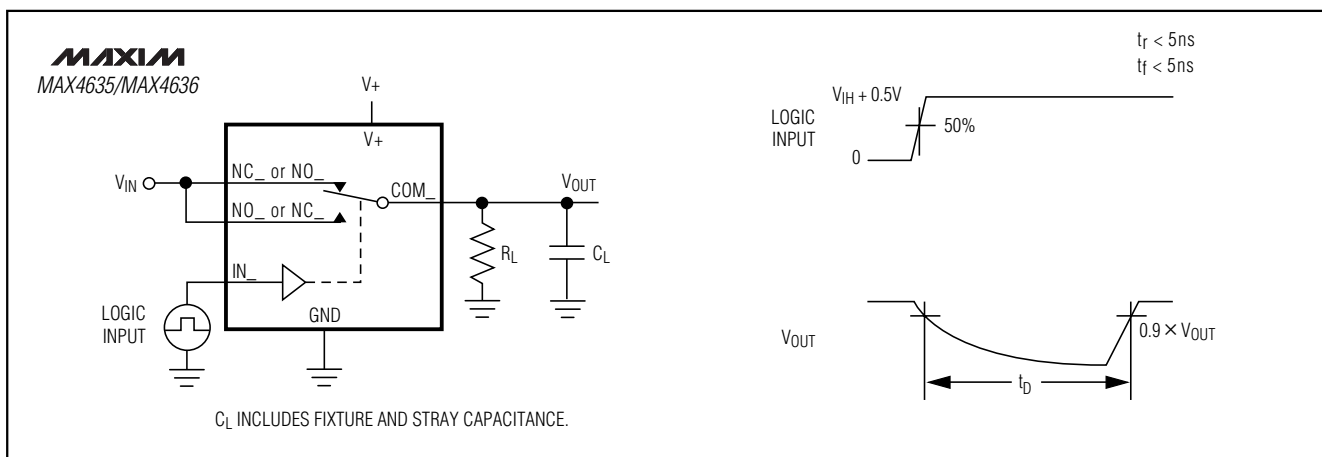

Figure 1b. Break-Before-Make Interval

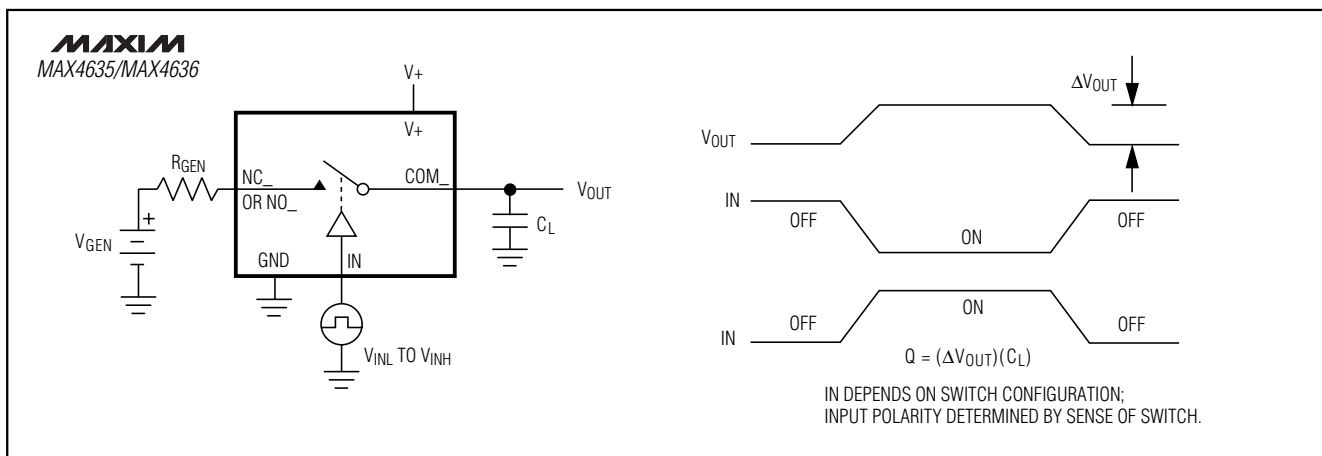

Figure 2. Charge Injection

# Fast, Low-Voltage, Dual 4Ω SPDT CMOS Analog Switches

## Detailed Description

The MAX4635/MAX4636 are low-on-resistance ( $R_{ON}$ ), low-voltage, dual SPDT analog switches that operate from a +1.8V to +5.5V supply. The MAX4635/MAX4636 feature very fast switching speed ( $t_{ON} = 14\text{ns}$  max,  $t_{OFF} = 6\text{ns}$  max) and guaranteed break-before-make switching. The low maximum  $R_{ON}$  allows high continuous currents to be switched in a variety of applications.

## Applications Information

### Logic Inputs

The MAX4635/MAX4636 logic inputs (IN1, IN2) can be driven up to +5.5V, regardless of the voltage on V+. This allows interfacing to 5V logic signals while operating with a +3.3V supply voltage without external level translation.

### Analog Signal Levels

Analog signals ranging over the entire supply voltage (V+ to GND) can be passed with very little change in on-resistance (see *Typical Operating Characteristics*). The switches are bidirectional, so the NO\_, NC\_, and COM\_ pins may be used as either inputs or outputs.

### Power-Supply Sequencing and Overvoltage Protection

**Caution: Do not exceed the absolute maximum ratings because stresses beyond the listed ratings can cause permanent damage to the device.** Proper power-supply sequencing is recommended for all CMOS devices. Always apply V+ before applying analog signals, especially if the analog signal is not current limited. If this sequencing is not possible, and if the analog inputs are not current limited to less than 30mA, add a small-signal diode (D1) as shown in Figure 5. If the analog signal can dip below GND, add D2. Adding protection diodes reduces the analog range to a diode drop (about 0.7V) below V+ (for D1), and a diode drop above ground (for D2).

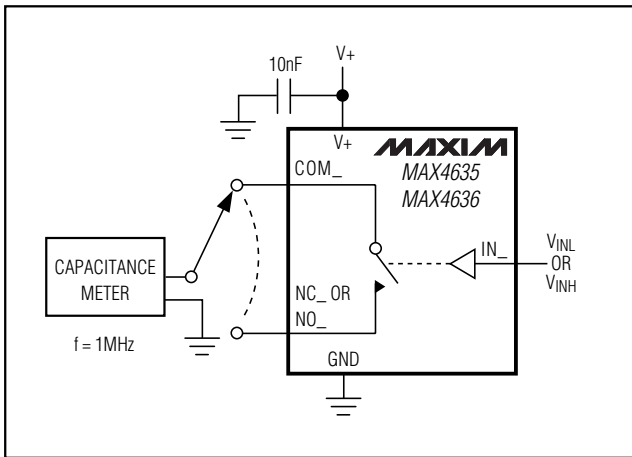

Figure 3. Channel Off/On-Capacitance

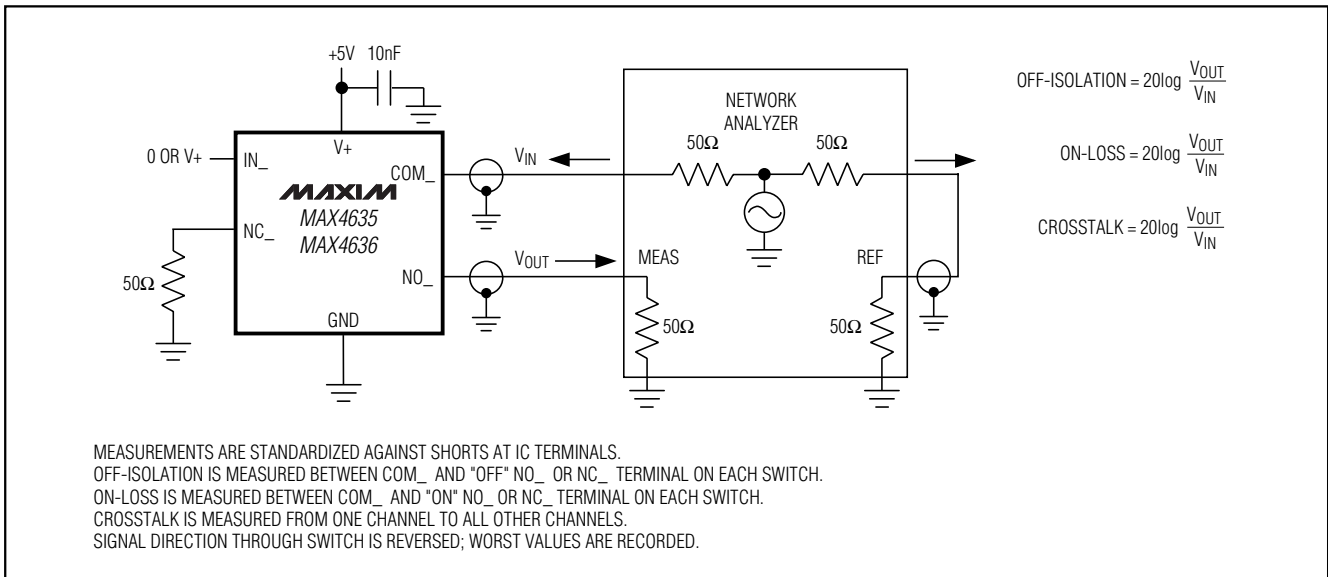

Figure 4. On-Loss, Off-Isolation, and Crosstalk

# Fast, Low-Voltage, Dual 4Ω SPDT CMOS Analog Switches

## Chip Information

TRANSISTOR COUNT: 239

PROCESS: CMOS

MAX4635/MAX4636

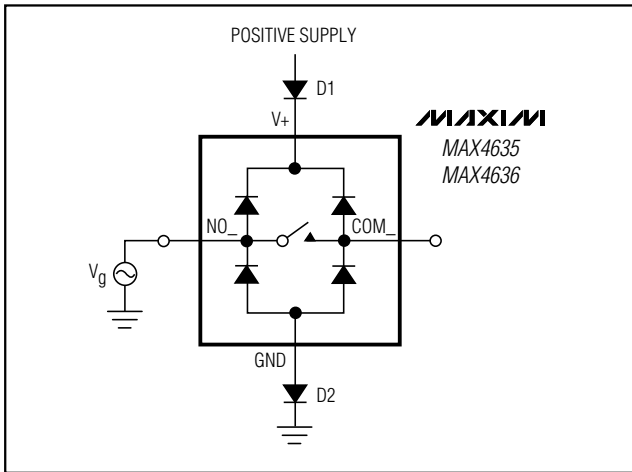

Figure 5. Overvoltage Protection Using Two External Blocking Diodes

On-resistance increases slightly at low supply voltages. Maximum supply voltage ( $V_+$ ) must not exceed +6V. Adding protection diode D2 causes the logic threshold to be shifted relative to GND. Protection diodes D1 and D2 also protect against some overvoltage situations. With Figure 5's circuit, if the supply voltage is below the absolute maximum rating, and if a fault voltage up to the absolute maximum rating is applied to an analog signal pin, no damage results.

# Fast, Low-Voltage, Dual 4Ω SPDT CMOS Analog Switches

## Package Information

(The package drawing(s) in this data sheet may not reflect the most current specifications. For the latest package outline information, go to [www.maxim-ic.com/packages](http://www.maxim-ic.com/packages).)

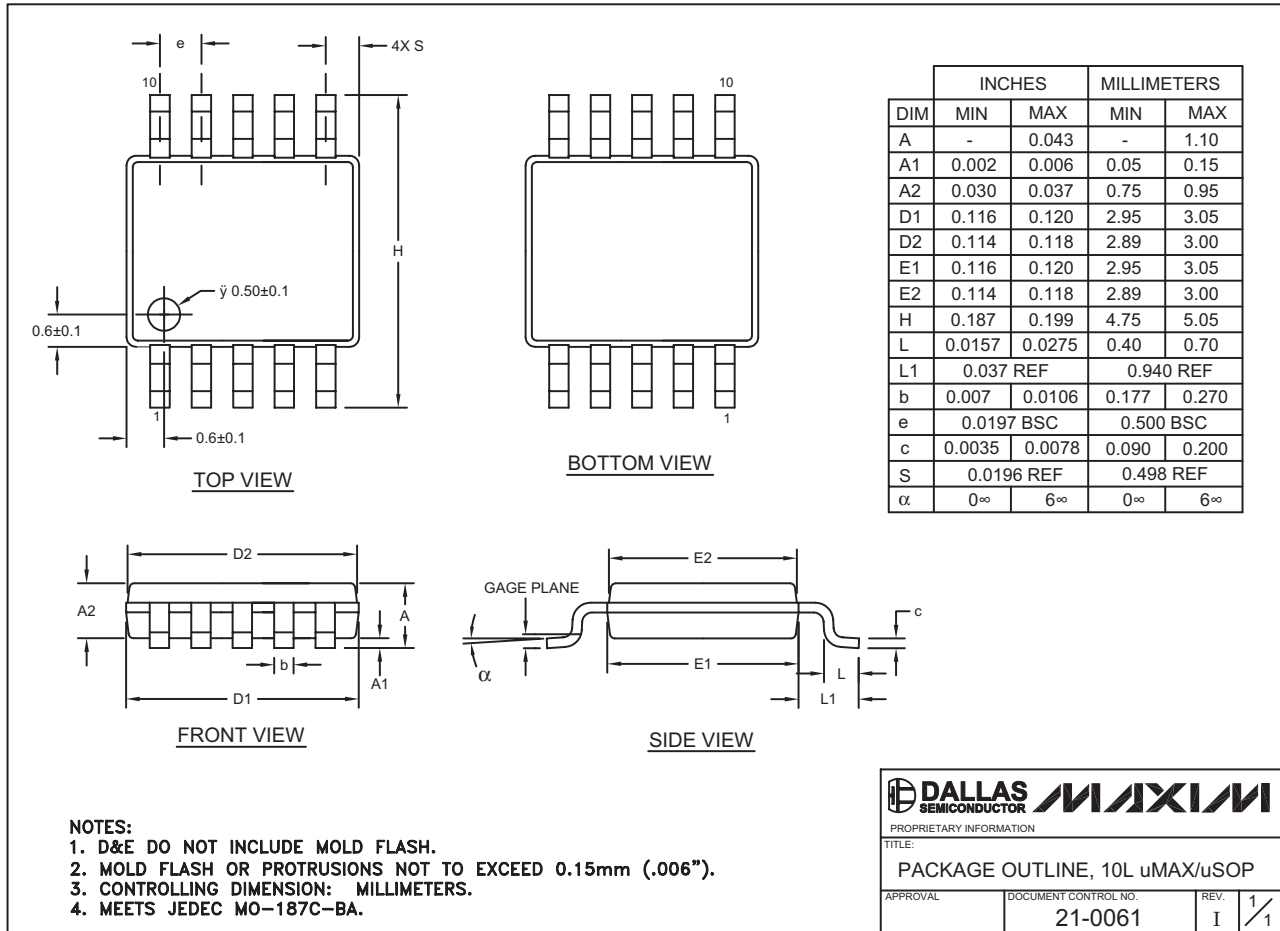

10LUMAXEPS

**Note:** The MAX4636 does not have an exposed pad.

# Fast, Low-Voltage, Dual 4Ω SPDT CMOS Analog Switches

## Package Information (continued)

(The package drawing(s) in this data sheet may not reflect the most current specifications. For the latest package outline information, go to [www.maxim-ic.com/packages](http://www.maxim-ic.com/packages).)

MAX4635/MAX4636

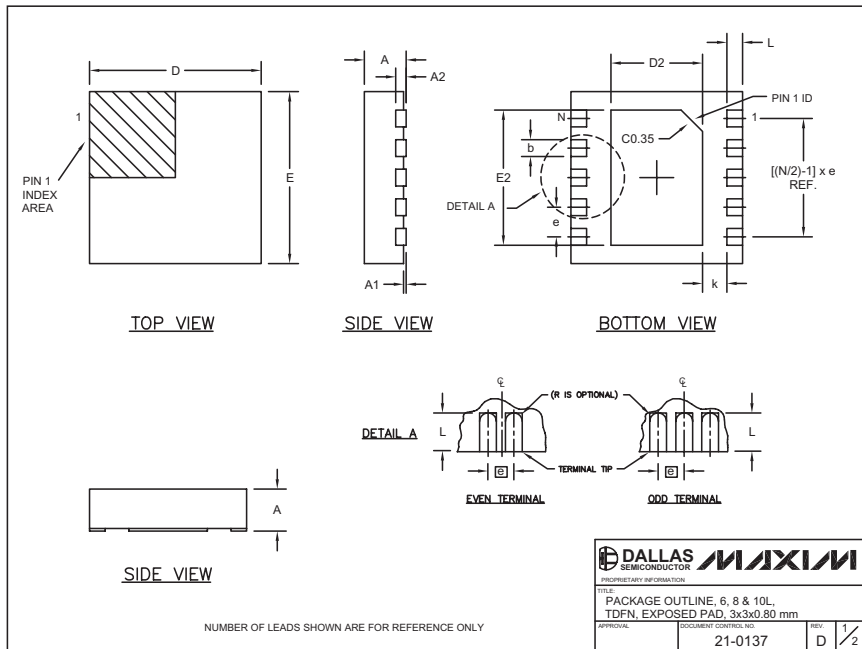

COMMON DIMENSIONS							
SYMBOL	MIN.	MAX.					
A	0.70	0.80					
D	2.90	3.10					
E	2.90	3.10					
A1	0.00	0.05					
L	0.20	0.40					
k	0.25 MIN.						
A2	0.20 REF.						

PACKAGE VARIATIONS							
PKG. CODE	N	D2	E2	e	JEDEC SPEC	b	[(N/2)-1] x e
T633-1	6	1.50±0.10	2.30±0.10	0.95 BSC	MO229 / WEEA	0.40±0.05	1.90 REF
T833-1	8	1.50±0.10	2.30±0.10	0.65 BSC	MO229 / WEEC	0.30±0.05	1.95 REF
T1033-1	10	1.50±0.10	2.30±0.10	0.50 BSC	MO229 / WEED-3	0.25±0.05	2.00 REF

NOTES:

- ALL DIMENSIONS ARE IN mm. ANGLES IN DEGREES.
- COPLANARITY SHALL NOT EXCEED 0.08 mm.
- WARPAGE SHALL NOT EXCEED 0.10 mm.
- PACKAGE LENGTH/PACKAGE WIDTH ARE CONSIDERED AS SPECIAL CHARACTERISTIC(S).
- DRAWING CONFORMS TO JEDEC MO229, EXCEPT DIMENSIONS "D2" AND "E2".
- "N" IS THE TOTAL NUMBER OF LEADS.

6, 8, & 10L, OFN THINLEPS

Maxim cannot assume responsibility for use of any circuitry other than circuitry entirely embodied in a Maxim product. No circuit patent licenses are implied. Maxim reserves the right to change the circuitry and specifications without notice at any time.

Maxim Integrated Products, 120 San Gabriel Drive, Sunnyvale, CA 94086 408-737-7600 \_\_\_\_\_ 11

SITE  
SEARCHPART NO.  
SEARCH

WHAT'S NEW

PRODUCTS

SOLUTIONS

DESIGN

APPNOTES

SUPPORT

BUY

COMPANY

MEMBERS

## MAX4636

### Part Number Table

#### Notes:

1. See the [MAX4636 QuickView Data Sheet](#) for further information on this product family or download the [MAX4636 full data sheet](#) (PDF, 256kB).
2. Other options and links for purchasing parts are listed at: <http://www.maxim-ic.com/sales>.
3. [Didn't Find What You Need?](#) Ask our applications engineers. Expert assistance in finding parts, usually within one business day.
4. Part number suffixes: T or T&R = tape and reel; + = RoHS/lead-free; # = RoHS/lead-exempt. More: See [full data sheet](#) or [Part Naming Conventions](#).
5. \* Some packages have variations, listed on the drawing. "PkgCode/Variation" tells which variation the product uses.

Part Number	Free Sample	Buy Direct	Package: TYPE PINS SIZE DRAWING CODE/VAR *	Temp	RoHS/Lead-Free? Materials Analysis
MAX4636ETB+G104	<input type="checkbox"/>	<input type="checkbox"/>	THIN QFN (Dual);10 pin;3X3X0.8mm Dwg: <a href="#">21-0137I</a> (PDF) Use pkgcode/variation: T1033+1*	-40C to +85C	RoHS/Lead-Free: <a href="#">Yes</a> <a href="#">Materials Analysis</a>
MAX4636ETB	<input type="checkbox"/>	<input type="checkbox"/>	THIN QFN (Dual);10 pin;3X3X0.8mm Dwg: <a href="#">21-0137I</a> (PDF) Use pkgcode/variation: T1033-1*	-40C to +85C	RoHS/Lead-Free: <a href="#">No</a> <a href="#">Materials Analysis</a>
MAX4636ETB+TG104	<input type="checkbox"/>	<input type="checkbox"/>	THIN QFN (Dual);10 pin;3X3X0.8mm Dwg: <a href="#">21-0137I</a> (PDF) Use pkgcode/variation: T1033+1*	-40C to +85C	RoHS/Lead-Free: <a href="#">Yes</a> <a href="#">Materials Analysis</a>
MAX4636ETB+T	<input type="checkbox"/>	<input type="checkbox"/>	THIN QFN (Dual);10 pin;3X3X0.8mm Dwg: <a href="#">21-0137I</a> (PDF) Use pkgcode/variation: T1033+1*	-40C to +85C	RoHS/Lead-Free: <a href="#">Yes</a> <a href="#">Materials Analysis</a>
MAX4636ETB+	<input type="checkbox"/>	<input type="checkbox"/>	THIN QFN (Dual);10 pin;3X3X0.8mm Dwg: <a href="#">21-0137I</a> (PDF) Use pkgcode/variation: T1033+1*	-40C to +85C	RoHS/Lead-Free: <a href="#">Yes</a> <a href="#">Materials Analysis</a>
MAX4636ETB-T	<input type="checkbox"/>	<input type="checkbox"/>	THIN QFN (Dual);10 pin;3X3X0.8mm Dwg: <a href="#">21-0137I</a> (PDF) Use pkgcode/variation: T1033-1*	-40C to +85C	RoHS/Lead-Free: <a href="#">No</a> <a href="#">Materials Analysis</a>
MAX4636EUB-T	<input type="checkbox"/>	<input type="checkbox"/>	uMAX;10 pin;3 x 3mm Dwg: <a href="#">21-0061I</a> (PDF) Use pkgcode/variation: U10-2*	-40C to +85C	RoHS/Lead-Free: <a href="#">No</a> <a href="#">Materials Analysis</a>

MAX4636EUB+			uMAX;10 pin;3 x 3mm Dwg: <a href="#">21-0061I</a> (PDF) Use pkgcode/variation: U10+2*	-40C to +85C	RoHS/Lead-Free: <a href="#">Yes</a> <a href="#">Materials Analysis</a>
MAX4636EUB+T			uMAX;10 pin;3 x 3mm Dwg: <a href="#">21-0061I</a> (PDF) Use pkgcode/variation: U10+2*	-40C to +85C	RoHS/Lead-Free: <a href="#">Yes</a> <a href="#">Materials Analysis</a>
MAX4636EUB			uMAX;10 pin;3 x 3mm Dwg: <a href="#">21-0061I</a> (PDF) Use pkgcode/variation: U10-2*	-40C to +85C	RoHS/Lead-Free: <a href="#">No</a> <a href="#">Materials Analysis</a>

[Didn't Find What You Need?](#)

[CONTACT US: SEND US AN EMAIL](#)

Copyright 2007 by Maxim Integrated Products, Dallas Semiconductor • [Legal Notices](#) • [Privacy Policy](#)