

Telecommunications Circuits

CD22212

CMOS Single-Chip 1200BPS MODEM

For Full-Duplex Operation over a Two-Wire Switched Telephone System

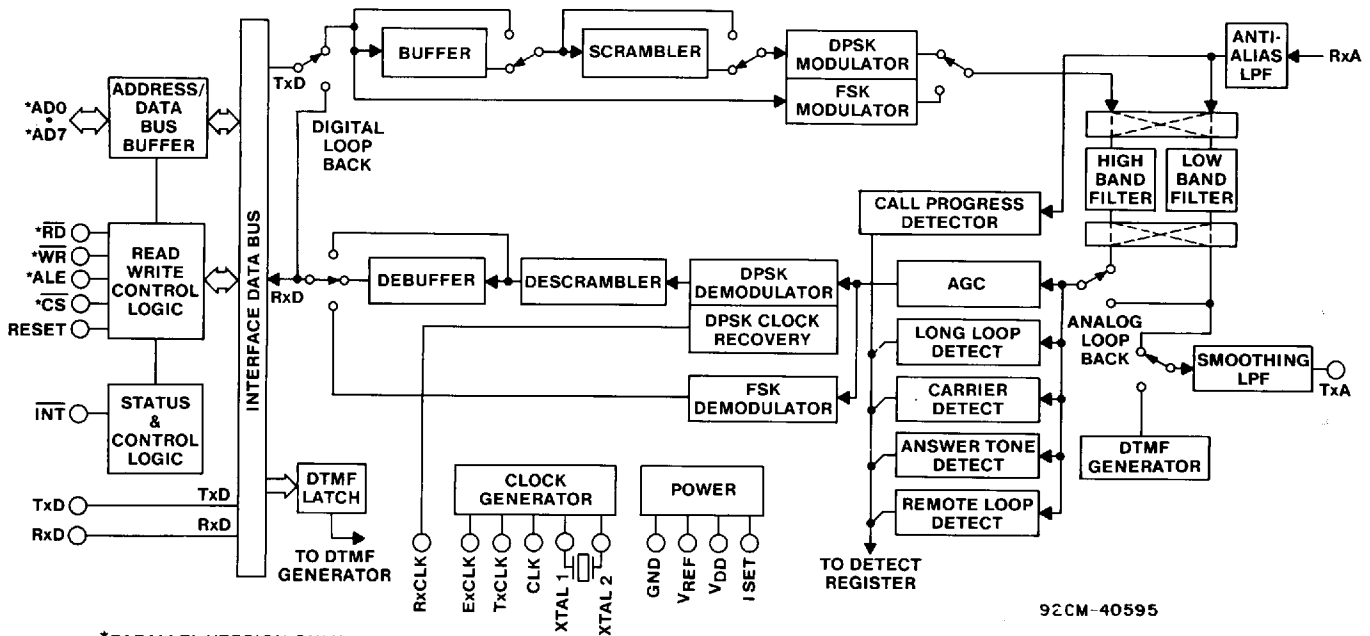

*PARALLEL VERSION ONLY.

92CM-40595

Type No.	Package	Operating Temp. Range
CD22212E	28-Lead DIP	0 to +70°C
CD22212E1	22-Lead DIP	0 to +70°C

The RCA-CD22212 is a single-chip modem device that provides the functions needed to construct a standard full-duplex modem that meets Bell 212A/103 modem specifications.

For use in stand-alone modems, the CD22212 requires only RS-232 level converters; for use in lap-top computers and PC modem cards, the CD22212 requires only the addition of a phone-line interface and a control microprocessor. The CD22212 interfaces directly with industry-type microprocessors such as the 8048 and 80C51 for control of modem functions.

The 22212 is especially useful in either freestanding or integral-system modem products where full-duplex 1200 BPS data communications over the 2-wire switched telephone network is desired. The high functionality, low power consumption, and efficient packaging of the CD22212 simplify design requirements and increase system reliability. In addition, coherent demodulation techniques assure the user of optimum performance when communicating over degraded lines.

Features:

- Full-duplex operation at 0-300 and 1200 BPS
- FSK (300 BPS) or PSK (1200 BPS) encoding
- Compatible with industry-type 8048, 80C51 up's
- Serial (22 Pin) or parallel up bus interface (28 Pin)
- Maskable Interrupts
- Serial port for data transfer
- Selectable asynch/synch; scrambler/descrambler functions
- Coherent demodulation technique provides optimum performance
- Call progress, carrier, and long-loop detect monitor
- DTMF tone generator
- Test modes available—ALB, DLB, RDL, Mark, Space, Alternating bit patterns
- Space-saving 22-pin DIP, 28-pin DIP packages
- CMOS technology for low power consumption (120 mW)
- Low power IDLE mode uses <10mW
- Single +12 V supply
- TTL and CMOS compatible inputs and outputs
- Interchangeable with SSIK212

Applications:

- Lap-top computers
- Stand-Alone Modems
- PC Modem cards
- Credit Verification